

PRODUCT SEAKEEPER SERIES MODELS

TROUBLESHOOTING GUIDE TABLE OF CONTENTS

CODE	DESCRIPTION	PG
1	Angle Sensor Calibration Required	322
6	Drive Temp High	58
8	Coolant Pump 1 Fault	88
9	Coolant Pump 2 Fault	88
12	Brake Pressure [1] Low	4
13	Brake Pressure [2] Low	4
14	Brake Pressure Low	4
15	SW Pump Overcurrent	95
16	Discrete Seawater Pump	101
19	Angle Sensor Fault [Active Range High]	322
26	Valve 1 Fault	21
27	Valve 2 Fault	21
32	Vertical Accel High	334
35	Display Fault	125
36	Motor Fault	138
37	Gyro Travel Fault	30
38	Gyro Motion Fault	30
39	Brake Travel Fault	30
40	Input Voltage High	144
41	Input Voltage Low	144
43	Power Relay	159
44	Sensor Power High	172
45	Sensor Power Low	172
50	Angle Sensor Fault	322
55	Angle Sensor Fault [Active Range Low]	322
56	Angle Sensor - Unresponsive	322
72	Motor Underspeed	178
73	Upper Bearing Temp High	113
74	Lower Bearing Temp High	113
75	IMU Fault	185
76	Roll Rate Fault	195
77	Yaw Rate Fault	195
78	Brake Valve Fault	21
79	Valve 3 Fault	21
80	Valve 4 Fault	21
82	Drive Age Count	199
83	Drive Voltage Fault	209
84	Drive CANBus Fault	199
85	Drive Software Fault	216
86	Drive Memory Fault	216
87	Drive Configuration Incorrect	216
88	Drive Wiring Fault	216
89	Drive Motor Control Fault	216
90	Motor Fault	216
91	Drive Hardware Incompatible	216
92	Drive MOSFET Fault	216
93	Drive IGBT Fault	216
94	Drive Preoperational	225
95	Drive Hardware Fault	226
96	Drive Fault	226

CODE	DESCRIPTION	PG
98	AC Mains Low	230
99	Motor Fault	235
100	Drive DSPPF Fault	235
101	Drive Pulsing Error	235
102	Drive OP Circuit	235
103	Drive Sensorless	252
104	Drive Temperature	58
105	Heater Delays Drive	119
106	Angle Sensor Fault	322
107	Display Software Incompatible	259
108	Drive Software Incompatible	259
109	Drive Software Model Incompatible	259
110	IMU Software Incompatible	259
111	DC Input Voltage Low	264
112	DC Input Voltage Low	264
115	Prop Valve Current High in Lock	52
116	Vacuum Leak	341
117	Enclosure Pressure Range High	341
118	Enclosure Pressure Range Low	341
123	Battery State of Charge Low	274
128	Vacuum Pressure	349
129	Incorrect Serial Number	276
130	Model Change Detected	276
131	GPS Signal Lost	277
132	ConnectBox Software Incompatible	259
137	Vacuum Sensor Fault [High]	349
146	Vacuum Sensor Fault [Low]	349
150	Lower Bearing Sensor Fault [High]	282
151	Lower Bearing Sensor Fault [Low]	282
152	Upper Bearing Sensor Fault [High]	282
153	Upper Bearing Sensor Fault [Low]	282
154	Power Relay Stuck on Fault	159
156	Drive Voltage	144
157	Drive Temperature	58
161	Heater Ineffective	119
162	Heater Not Present	119
163	Slow Spool Up	289
165	Bearing Temp Sensors Not Functioning	282
167	High Current DC Voltage Low	264
168	High Current DC Voltage High	264
251	No Connection to Gyro	125
252	Gyro Incompatible	259
BRAKE	Brake Override Inoperable	55
CORR	Corrosion	370
MFD	MFD Integration Issues	297
PERF	Performance Issues	376
NOISE	Noise & Vibration	357
TORQ	Torque Specifications	381
SCHEM	Wire Harness Schematics	304

PRODUCT SEAKEEPER SERIES MODELS

INTRODUCTION

All alarms cut power to the flywheel motor, lock the brake, and display an alarm pop up. The reset button must be pressed from the alarm overlay page to clear alarms. The power button must be pressed to begin respooling.

Certain alarm codes require power cycle to reset the alarm(s) due to the seriousness of the applicable alarms. In the event of these alarms, the Seakeeper must be visually inspected for issues. A list of the applicable codes are as follows:

- Codes **19, 50, 55, 56,** and **106:** Angle sensor Faults
- Codes **26, 27, 78, 79,** and **80:** Brake Valve Faults
- Codes **37, 38, 39,** and **115:** Seakeeper Travel and Motion Faults
- Codes **44** and **45:** Sensor Power Faults

Continued operation may result in damage to equipment or injury.

If apparent causes cannot be found during troubleshooting, the technician is requested to compile the following information for submission to Seakeeper Product Support Team for review to better assist the technician:

Vessel Make & Model	Photo of display Service screen
Case Number, if opened	Photo of Alarm History
Reported issue	Summary of troubleshooting performed with readings recorded
Photo of display Information screen	Video of unusual RPM readings, noises from sphere, any occurrence out of ordinary

Once all requested data compiled, submit to Seakeeper Product Support Team via email (support@seakeeper.com) or through Drop Box, or similar service.

The 3.5" Display may show alarms with improper alarm description. Troubleshoot alarms, warnings, and notices based on the code number versus the alarm description.

To navigate through links within this document (Attachments, other guides, and step references), use the [Alt] + [←] to return to source link. The first page of each guide has a home icon [⏠] to return user to table of contents page (or press home key on keyboard). External links open windows of the Dealer Access portal. These links are referenced documents, drawings and other procedures throughout the guide. In order to maintain your location in this document, open these links by right-clicking on them and selecting "Open link in new tab" if viewing this document in a browser.

Subsystems are listed as follows:

Brake Subsystem	Pages 4 to 57
Coolant Subsystem	Pages 58 to 124
Electrical Subsystem	Pages 125 to 321
Foundation/Enclosure Subsystem	Pages 322 to 381

PRECAUTIONS

1. PERSONNEL INJURY MAY RESULT if Seakeeper is NOT locked and at zero RPM before removing covers or accessing unit for service.
2. PERSONNEL INJURY MAY RESULT if attempting to perform maintenance on Seakeeper without removing flywheel motor power and applying lockouts due to remote start capabilities.
3. PERSONNEL SHOCK HAZARD EXISTS in Motor Drive when flywheel rotating OR at zero speed for minimum of ten minutes.
4. PERSONNEL SHOCK MAY OCCUR if NOT wearing appropriate OSHA Class 00 electrical personal protective equipment when troubleshooting Seakeeper live electrical circuits.
 - a. Seakeeper recommends arc-flash gloves (McMaster #9353T9), or similar, and safety glasses.



5. INACCURATE RESISTANCE READINGS MAY RESULT from resistance checks on energized circuits.
6. CONNECTOR SOCKETS MAY BE DAMAGED if using unapproved test probes and accessories when troubleshooting electrical connectors.
7. PERSONNEL CRUSHING HAZARD EXISTS when working near operating Seakeeper when in UNLOCKED/SEA mode.

REVISION	DESCRIPTION	APPROVAL	DATE
7	Added SF-90683 form in certain guides. Added Seakeeper 40 new harness schematic. Added sphere weights.	A Patricio	25JUN2024
8	Edited multiple steps. Added updated software functions. Added Seakeeper 40 electric ball valve operation.	A Patricio	07OCT2024

CODE 12/13/14

Troubleshoot and repair low brake pressure alarms: Codes 12, 13, and 14.

BACKGROUND

The Seakeeper hydraulic brake subsystem is charged to a set pressure depending on the model. If the brake pressure drops below a setpoint pressure, the Seakeeper will indicate a low brake pressure alarm. An alarm will lock the hydraulic system, and the Seakeeper will start spooling down. The settings and applicable codes vary by model per [ATTACHMENT 1](#).

Code 12: HYDRAULIC BRAKE PRESSURE SWITCH 1 LOW

Code 13: HYDRAULIC BRAKE PRESSURE SWITCH 2 LOW

Code 14: HYDRAULIC BRAKE PRESSURE SWITCH 1 AND 2 LOW

Technical bulletin 90616 discusses the two designs of brake manifolds used in Seakeepers, Bi-Directional and Rectified. The two types have the following distinguishing features:

Bi-Directional Manifolds have:

- Two accumulators
- Either two cartridge style check valves in manifold or two inline fitting check valves under their accumulators to regulate flow in/out of accumulators

Rectified Manifolds have:

- One accumulator (often larger than on Bi-Directional)
- Either four cartridge style or hidden internal check valves in manifold that have nothing to do with regulating flow in/out of the accumulator

REFERENCES

[TB-90616 - Seakeeper Rectified Manifolds](#)

[SWI-103 - Seakeeper Brake Service Procedure](#)

P/N 10384 or 90485, Seakeeper brake service kit & brake service bundle kit

PRECAUTIONS

- See [PRECAUTIONS](#) section.

PROCEDURE

1. **CHECK** hydraulic pressure in Seakeeper brake system as follows:
 - a. **TURN OFF** high current DC/AC power breaker to Seakeeper.
 - b. **ENSURE** Seakeeper flywheel at zero RPM at display/MFD app.
 - c. **ACTIVATE** Brake Override.
 - d. **INSTALL** Seakeeper pressure gauge (P/N 12830) or brake charge hose to brake manifold per [SWI-103 - Seakeeper Brake Service Instruction](#) to determine as-found hydraulic pressure in brake system. [**NOTE:** Do not connect cylinder vents.]
 - e. **MANUALLY PRECESS** enclosure fully forward and aft with Seakeeper still pressurized and watch pressure gauge.
 - i. **NOTE** any pressure spikes of 50 psi or more for later reference.

**NOTE:**

Brake pressure can fluctuate. Causes can be such as cooling or warming of the hydraulic oil due to use or lack of use, ambient temperatures, extreme low temperatures, etc.

- f. **IF** brake pressure is found below pressure graphed on [ATTACHMENT 2](#), based on ambient temperature,
THEN REFER to [SECTION 1](#) of this document.
- g. **IF** brake pressure is found at or above pressure graphed on [ATTACHMENT 2](#), based on ambient temperature,
THEN REFER to [SECTION 2](#) of this document.

Section 1: Low Brake Pressure Found**Section 1A: Checking for Brake Fluid Leaks**

1. **INSPECT** brake cylinders:

NOTE:

A thin film of oil on cylinder rods is normal.
Formation of drops of oil that run, and pool is excessive.

- a. **IF** drops of oil residue are found leaking from rod end seals, **THEN REPLACE** leaking brake cylinder(s) per [SWI-111](#).

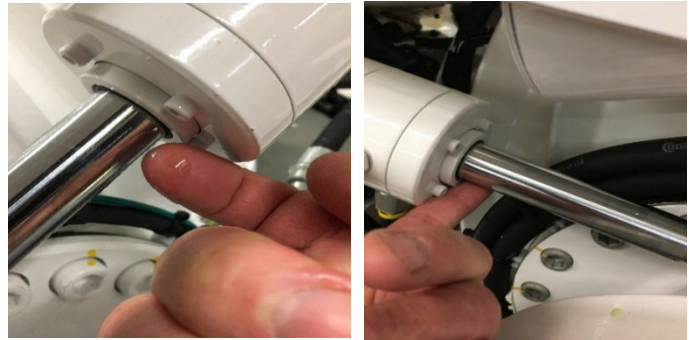

2. **INSPECT** all hydraulic hoses, connection fittings at brake cylinders, manifold, and manifold components.

- a. **IF** any oil residue is found on hydraulic connections, **THEN TIGHTEN** connection(s) to torques listed in [Torque Specifications](#) section.
- b. **IF** leaking connections are found tight, **THEN REPLACE** associated hose(s).

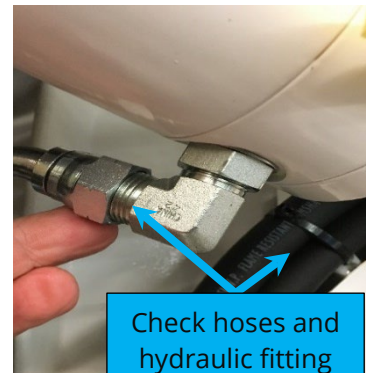
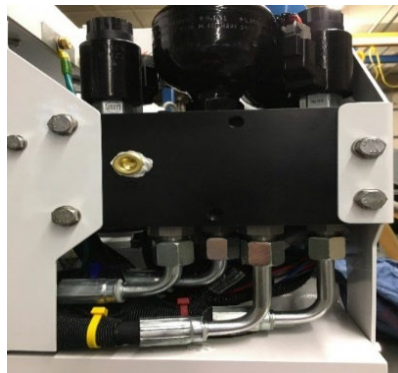
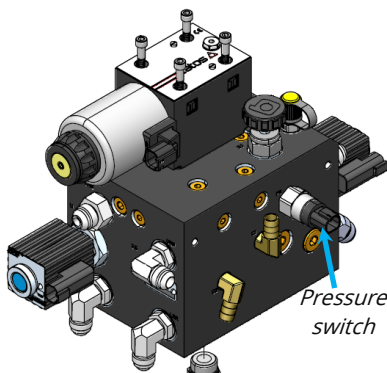

- c. **IF** leaks found and repaired, **THEN RESTORE** pressure **AND VERIFY** all alarms clear.

3. **IF** no leaks are found, **THEN PROCEED TO** [SECTION 1B](#).

Section 1B: Accumulator Inspection

Accumulators are a consumable part that are not field-serviceable. They contain a diaphragm inside to create two sections isolated from each other. The one section is filled by its manufacturer to a specific pressure with nitrogen. The other side of the diaphragm is in contact with the hydraulic oil of the brake system. It is used to store a volume of oil at charge pressure and absorb fluid due to changes in temperature.

Two types of accumulator construction have been used on Seakeepers:

Legacy accumulators had a resealable valve or plug charging port on its nitrogen side. Most **Newer accumulators** are charged with nitrogen that is then permanently sealed via a welding process.

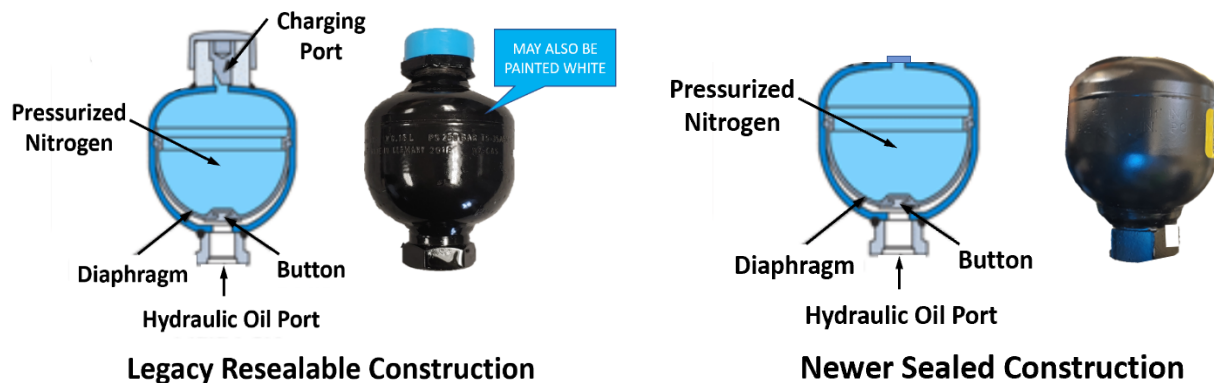

An Accumulator diaphragm can fail and allow nitrogen and oil to mix. When looking in the hydraulic oil port of an accumulator the plastic "button" of the diaphragm should be visibly pressed up against the opening. If the diaphragm has failed it will often deflate entirely within the accumulator, but may not, due to being filled with oil.

A legacy resealable accumulator may also commonly fail due to nitrogen leaking out of its resealable charging port. All or some of the nitrogen pressure may be lost impacting performance. The nitrogen cannot be recharged in the field.

If an accumulator has failed, it should be returned to Seakeeper if under warranty. If the Seakeeper unit is not under warranty, dispose of accumulator in accordance with local ordinances, unless requested by Seakeeper Product Support Team.

PRODUCT SEAKEEPER SERIES MODELS

Code 12/13/14

4. **INSTALL** Brake Service Kit per [SWI-103](#) and depressurize system.
5. **VERIFY** all hydraulic pressure released from brake manifold. [**NOTE:** Check valves may hold pressure while remainder of system depressurized.]

NOTE:

There are a variety of ways to remove accumulators depending on access and manifold model. On most Seakeeper models, a strap wrench or an oil filter wrench may work.

CAUTION:

**CONTAMINATION AND AIR INTRODUCTION INTO
BRAKE SYSTEM MAY RESULT FROM OPENING MANIFOLD.**

6. **PLACE** shop rag/towel around base of accumulator in event there is oil pressure between check valve and accumulator.
7. **IF** accumulator installed upside-down, **THEN PLACE** oil catch device or bag beneath accumulator.

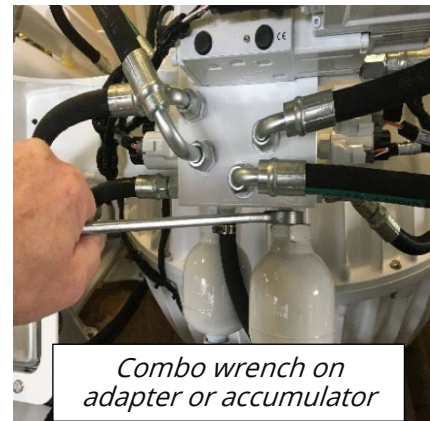
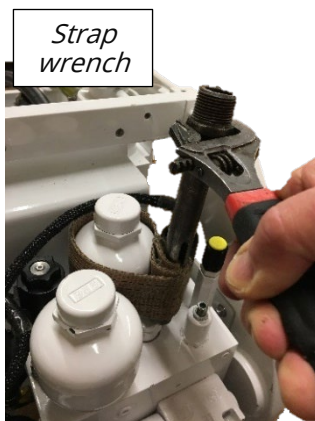

8. **REMOVE** accumulator(s).

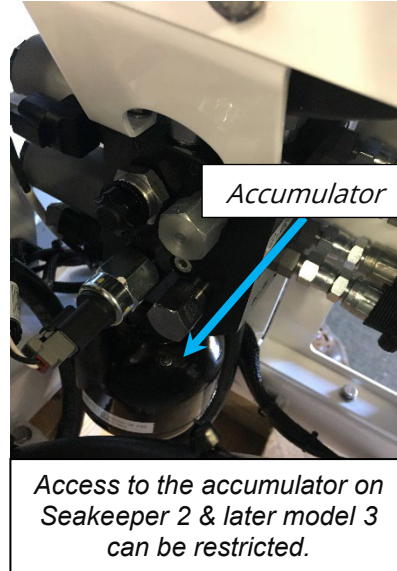



WARNING!

PERSONNEL EYE INJURY FROM PRESSURIZED FLUID EXISTS
when testing accumulator button.

9. With splash-proof goggles/face shield, **TEST** accumulator(s) as follows:



- a. **PRESS** on "button" of diaphragm with a non-sharp tool, such as a marker.
- b. **IF** diaphragm deflates **OR** button can be depressed by hand, **THEN REPLACE** accumulator.
- c. **IF** one accumulator faulty on bi-directional manifold, **THEN REPLACE BOTH** accumulators together.
- d. **IF** diaphragm button remains firm and of sealed construction, **THEN DO NOT REPLACE** accumulator; it has not failed.

NOTE:

Check valves of a rectified manifold are NOT in the accumulator flow path.
The single accumulator found on rectified manifolds has no check valve in its discharge, like those of bi-directional design.

10. **IF** pressure found when opening bi-directional brake system,
THEN CLEAN OR REPLACE cartridge check valve **OR** check valve adapter.



Cartridge type check valve



Technician inspecting and cleaning an adapter-type check valve.

11. **USE** bulb aspirator to draw out any debris or excess oil from manifold cavities.

Bulb aspirator removing excess oil or debris in cavity.

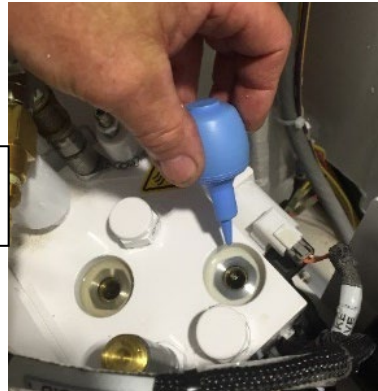

PRODUCT SEAKEEPER SERIES MODELS

Code 12/13/14

12. **IF** replacing adapter check valves and accumulators, **THEN INSTALL** adapter check valves (with arrow pointing toward manifold) before installing accumulators.

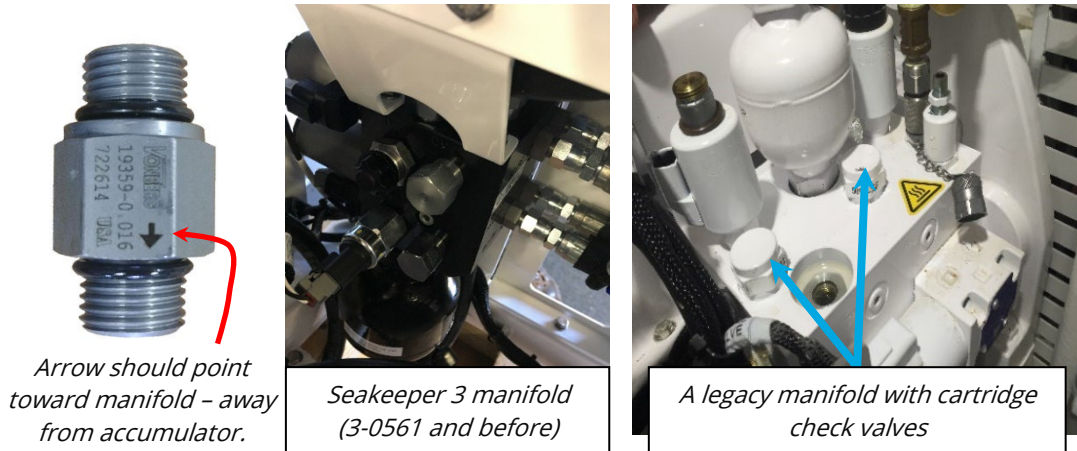

13. **IF** accumulator installed upright on manifold, **THEN SLOWLY PUMP** oil into manifold so open port is filled with hydraulic oil before inserting accumulator to minimize air introduced into system.
14. **INSTALL** accumulator.
15. **WIPE** oil residue on and around brake manifold.
16. **PERFORM** brake service procedure per [SWI-103](#) to return system to normal charge pressure per [Attachment 1](#).
17. **VERIFY** all alarms clear.
- **IF** alarm persists, **THEN PERFORM** checks of [Section 2](#).

Section 2: Brake System at Charge Pressure**Section 2A: Inspect Connector Integrity**

1. **DISCONNECT** pressure switch harness connector(s).

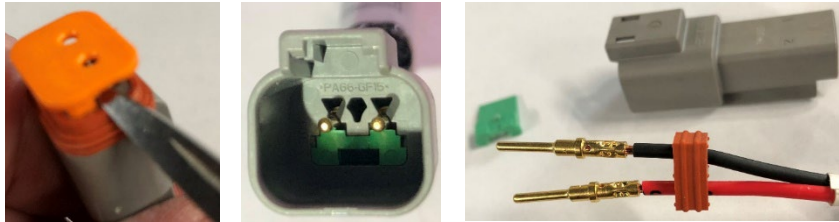

2. **VERIFY** pins are fully inserted and wire crimps intact.
3. **IF** pins or crimps loose, **THEN REPAIR** connector.

Section 2B: Inspect Pressure Switch Functionality

4. **DISCONNECT** GCM 70-pin connector.
5. **VERIFY** pins are fully inserted and wire crimps intact.



6. **IF** wires or crimps of 70-pin connector loose or damaged, **THEN REPAIR** connector **OR REPLACE** wire harness.
7. **TEST** electrical integrity of brake pressure switches as follows:

- a. **RECONNECT** GCM 70-pin connector.
- b. **RAISE** brake system pressure above alarm setpoint pressure ([See Attachment 1](#) for alarm setpoint pressure).

- c. **CLOSE** brake service manifold valves.
- d. With multimeter in “DC Volts” mode **MEASURE** across pins **A/1** and **C/2** on pressure switch using back probes in connector.

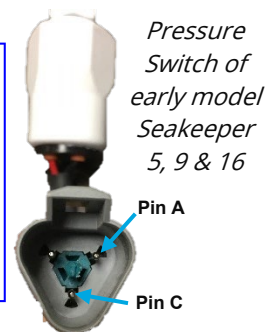
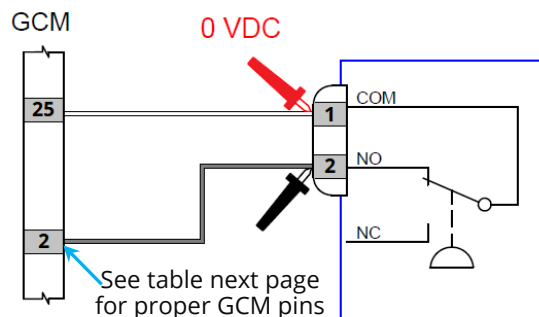

- e. **IF** 5VDC seen (switch open/ alarm active), **THEN:**

- i. **REPLACE** pressure switch.
- ii. **VERIFY** alarm clears.

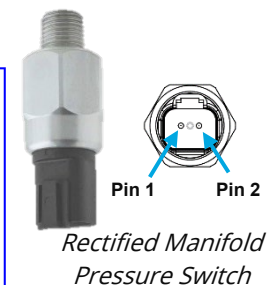
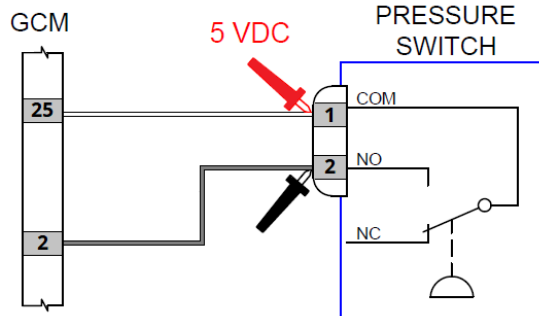

- f. **IF** zero VDC seen, **THEN PERFORM** Section 2C (next page) to check harness integrity.

Section 2C: Inspect Harness Integrity

8. **CONFIRM** less than 0.3Ω resistance between GCM 70-pin connector and pressure switch connector(s) as follows:

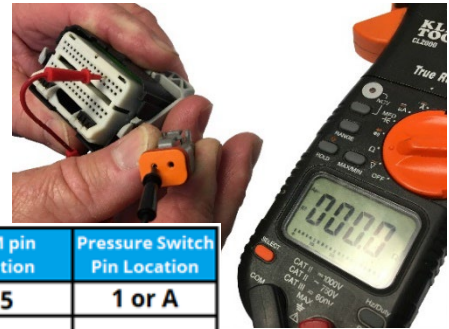
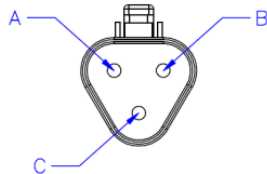

Pressure Switch	Seakeeper Model	GCM pin location	Pressure Switch Pin Location
1	ALL	25	1 or A
	1, 9 (bi-directional), 16(EM), 16/18, 26, 35	32	2 or C
	2, 3, 5/3DC(EM), 6/5	2	
2	ALL bi-directional models	27	1 or A
	9 (bi-directional), 16(EM), 26, 35, & 40	32	2 or C
	5/3DC(EM), 6/5 (bi-directional)	2	

CAUTION:

GCM connector damage can occur if a large pin is inserted into the plug.
Multimeter test pins cannot exceed 0.10 inch in diameter.

- a. **VERIFY** below 0.3Ω between GCM pin **25** to pin **A/1** of #1 pressure switch plug.
- b. **VERIFY** below 0.3Ω between GCM pin **32 (2)** and pin **C/2** of #1 pressure switch plug per above table and Seakeeper Model.
- c. **IF** equipped with pressure switch #2, **THEN VERIFY** below 0.3Ω between GCM pin **27** to pin **A/1** of #2 pressure switch plug.
- d. **IF** equipped with pressure switch #2, **THEN VERIFY** below 0.3Ω between GCM pin **32 (2)** to pin **C/2** of #2 pressure switch plug.
- e. **IF** resistance checks of Step 8.a through 8.d are **UNSATISFACTORY**, **THEN REPLACE** wire harness.
- f. **IF** resistance checks of Step 8.a through 8.d are **SATISFACTORY** and zero VDC seen on voltage check of Step 7.d, **THEN REPLACE** pressure switch.

Section 2D: Inspect Bi-Directional Check Valve Integrity

Rectified manifolds have check valves that are **NOT** to be serviced; the manifold would be replaced.

On a bi-directional manifold, check valves are in the oil flow path between the two accumulators and the system (see schematic below). A clogged or faulty check valve will interrupt the normal flow of oil in/out of the accumulators and may cause abnormal precession, accumulator failure or low-pressure alarms.

Early bi-directional manifold designs used cartridge check valves installed in the manifold and were often painted white. New accumulators do not fit the legacy style manifolds without the use of a flow-through adapter; ensure the adapter is present when installing a new accumulator to a legacy manifold.

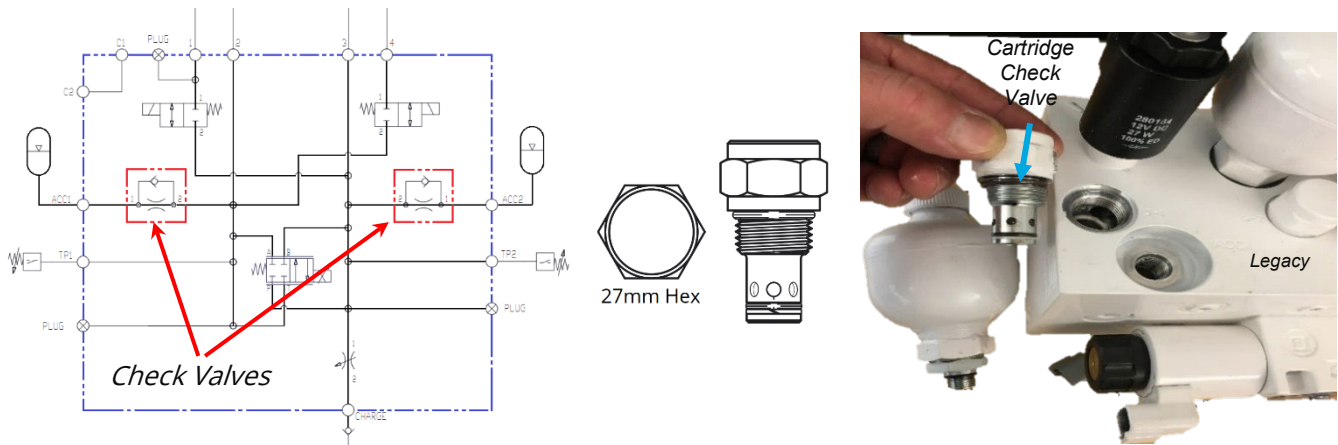

On some models, check valves double as the adapter fittings used to attach accumulators directly to the manifold. They are identifiable by an arrow on their side indicating the free flow path that **MUST** point towards the manifold.

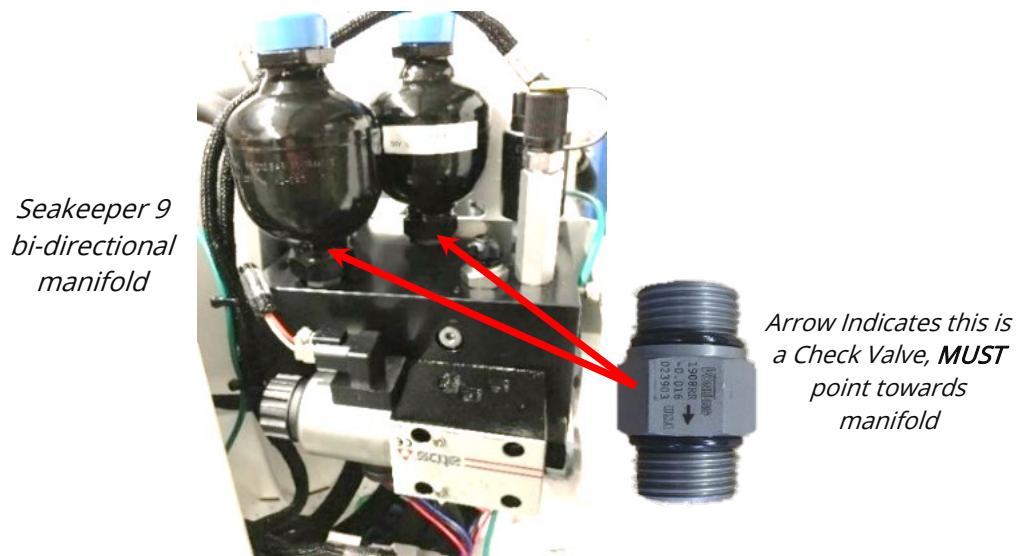

9. **IF** manifold has in-line check valve adapter on accumulators, **THEN VERIFY** both check valves are installed arrows pointing towards manifold.
10. **IF** bi-directional manifold and any of following:
- When manually precessing sphere forward and aft and brake pressure fluctuates more than 50 psi on pressure gauge attached.
 - When charging brake system from zero pressure and pressure climbs to 200 psi with two pumps of brake service pump.
 - When removing accumulator from a depressurized manifold, there is oil pressure found under accumulator.

THEN REPLACE both check valves.

11. **IF** any above are not true, **THEN:**

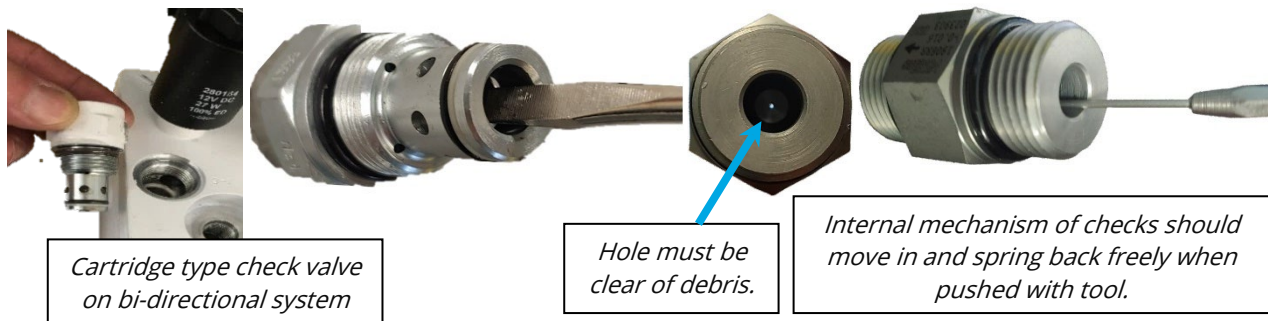

- a. **REMOVE** check valves.
- b. **CLEAN OR REPLACE** if signs of debris or malfunction.

12. **IF** replacing a check valve, **THEN:**

- a. **REMOVE** check valve(s) from accumulator or manifold.
- b. **IF** cartridge-style check valves, **THEN:**
- i. **ENSURE** no debris in manifold port.
 - ii. **SLOWLY PUMP** oil into manifold to fill port with hydraulic oil to reduce amount of air trapped in manifold.
 - iii. **INSTALL** check valve(s) before accumulator.
 - iv. **INSTALL** flow-through adapter(s) into accumulators.

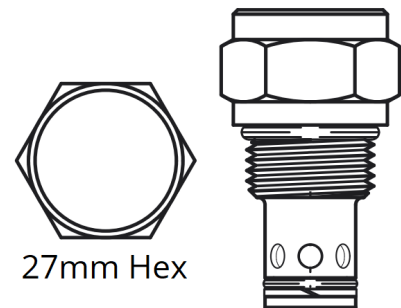

Cartridge-style check valve

Section 2D, Step 12 continued

- c. **IF** working with in-line style adapter check valves,
THEN:
 - i. **INSTALL** in-line check valve into accumulator with flow direction arrow pointing away from accumulator.
 - ii. **INSTALL** accumulator onto in-line check valve.
 - d. **WIPE** any oil residue on and around brake manifold.
13. **PERFORM** brake service following [SWI-103: Brake Service Instruction](#).
 14. **VERIFY** all alarms clear.

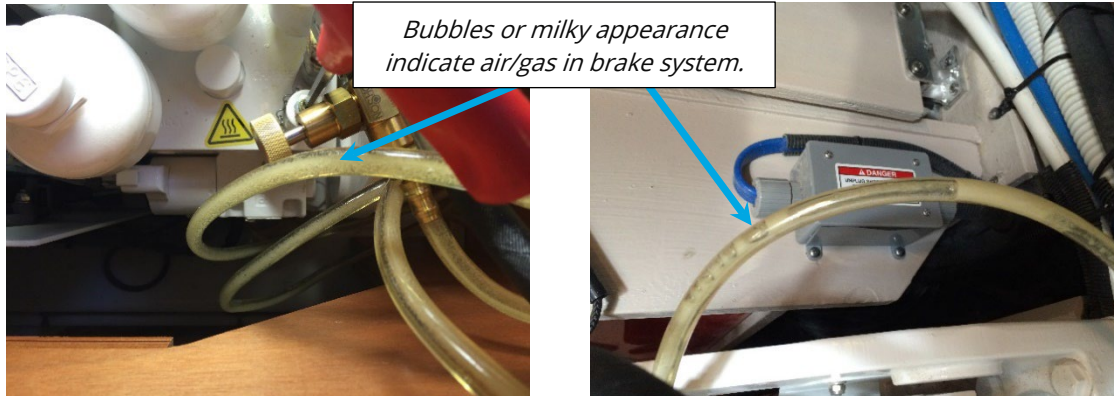

*In-Line style
check valve*

Section 2E: Air in Hydraulic System

Gases can be introduced into a brake system through several methods: accumulator diaphragm failure, inadequate system venting after any maintenance that breaches the pressure boundary, and pockets of air trapped when installing components at the manifold or the cylinders. Gas present in the brake subsystem may cause a Brake Pressure Low alarm. Perform a brake service per this section. The bled fluid will appear milky or show bubbles in the drain tubes. Rectified manifolds may display air with no accumulator issue. Air in fluid may be due to air introduction from regular brake service.

PRESSURIZE HYDRAULIC BRAKE SYSTEM

15. **TEST** accumulator(s) per [SECTION 1B](#).
16. **PERFORM** thorough venting of all gases per [SWI-103: Brake Service Instruction](#).
17. **START** Seakeeper.
18. **PERFORM** sea trial and monitor for alarms.
 - a. **IF** alarm persists,
THEN PERFORM [SECTION 2B](#) to test manifold pressure switch and wiring.

******* END *******

ATTACHMENT 1 – Brake Pressure / Alarm Threshold

BRAKE PRESSURE / ALARM THRESHOLD							
MODEL (Serial #)	Manifold Type	CHARGE PRESSURE (PSI/BAR)	ALARM THRESHOLD (PSI/BAR)	VALID ALARMS BY MODEL			DRAWING NO.
				CODE 12	CODE 13	CODE 14	
SEAKEEPER 2 (2-0001 – 2-0071)	Rectified	240/16.5	72/5	X			50249
SEAKEEPER 2 (2-0072 to Current)		350/24.1	215 ¹ /14.8	X			
SEAKEEPER 3 (3-0001 to 3-0561)	Rectified	240/16.5	72/5	X			50197
SEAKEEPER 3 (3-0562 to Current)	Rectified	350/24.1	215 ¹ /14.8	X			50249
SEAKEEPER 5/3DC(EM) (5-0001 to 5-1049)	Bi- directional	240/16.5	72/5			X	10930
SEAKEEPER 6/5 (5-193-1512 to 5-194-1935) (6-0001 to 6-201-1934)	Bi- directional	240/16.5	72/5			X	50216
SEAKEEPER 6/5 (5-201-1969 – 5-234-6408) (6-201-1936 – 6-234-6432)	Rectified	350/24.1	150/10.3	X			50290
SEAKEEPER 6/5 (5-234-6494 – 5-242-6708) (6-234-6433 to Current)			165 ^{1,2} /11.4	X			
SEAKEEPER 9/7HD (9-0001 – 9-201-2838)	Bi- directional	240/16.5	72/5			X	50215
SEAKEEPER 9/7HD (9-201-2839 to Current)	Rectified	350/24.1	230 ¹ /15.9	X			50316
SEAKEEPER 16/12HD(EM) (16-0001 to 16-193-0912)	Bi- directional	240/16.5	72/5	X	X		50250
SEAKEEPER 18/16/12HD	Rectified	350/24.1	200/13.8	X			50298
SEAKEEPER 26/20HD	Bi- directional	240/16.5	72/5	X	X		11067
SEAKEEPER 35/30HD/40	Bi- directional	240/16.5	72/5	X	X		11067

EM = Legacy Discontinued Seakeeper Model**1** ±15 psi**2** pressure switch 50408 is backward compatible to 5/6-1936

ATTACHMENT 2 – CHARGE PRESSURE BASED ON TEMPERATURE

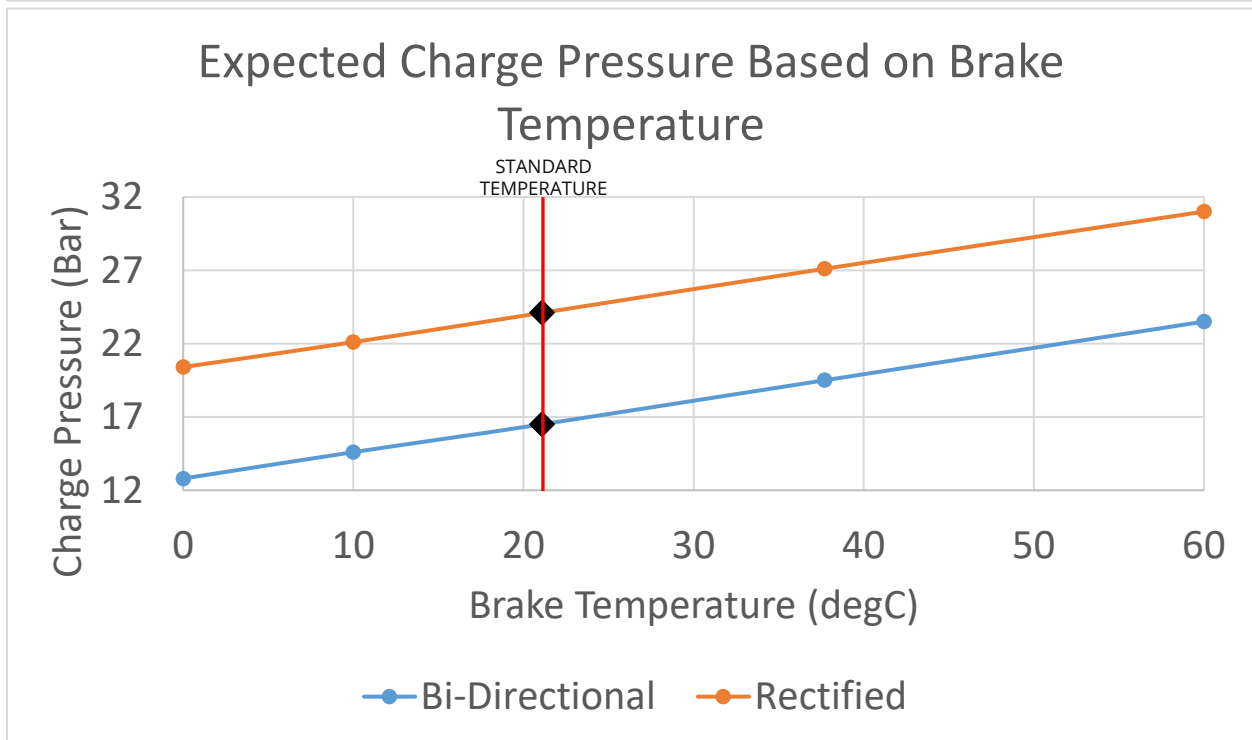
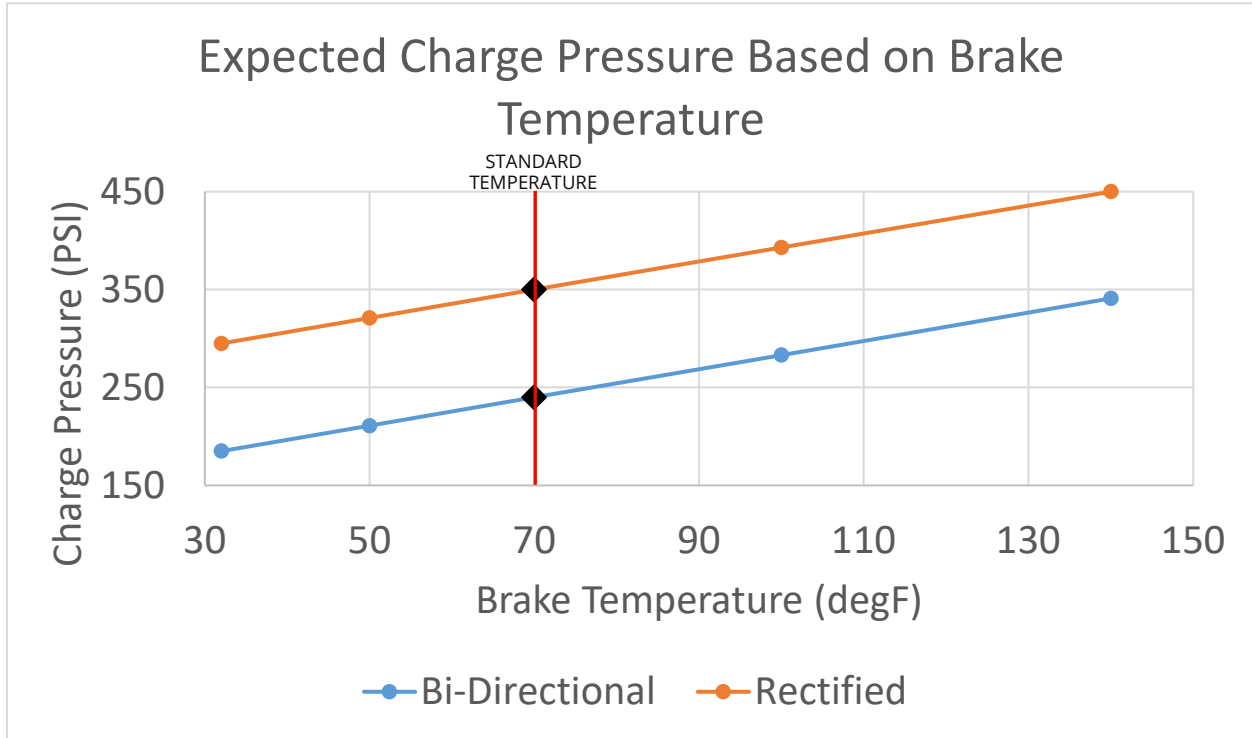

CODE 26/27/78/79/80 ⏪

To troubleshoot and repair the locking and proportional valve fault alarms.

CODE 26: VALVE 1 FAULT

CODE 27: VALVE 2 FAULT

CODE 78: BRAKE VALVE FAULT (Proportional Valve)

CODE 79: VALVE 3 FAULT (Seakeeper 16 (EM), 26, 35, & 40 models)

CODE 80: VALVE 4 FAULT (Seakeeper 16 (EM), 26, 35, & 40 models)

BACKGROUND

Continued operation with any of these codes may result in damage to equipment or injury. Power to the Seakeeper must be cycled to reset any of these alarms.

These codes will alarm at any time the GCM senses a loss of connection to a solenoid valve coil OR the valve is not operating correctly. The two-way locking valves 1, 2, 3, and 4 are used to isolate hydraulic oil flow to the cylinders when locked. Many models only have two locking valves (Seakeeper 2 through 18). The proportional brake valve is used to regulate flow to the cylinders when unlocked. All valves are energized when Seakeeper is unlocked at speed or manually overridden at 0rpm.

Likely Alarm Causes:

- Faulty valve solenoid coil
- Disconnected wire harness connectors or damage connector pins
- An open or short of wires within wire harness
- Faulty GCM

REFERENCES

Applicable Seakeeper Service Drawings

PRECAUTIONS

1. See [PRECAUTIONS](#) section in introduction.
2. BURN HAZARD exists on brake solenoid coils after energized for extended periods.

PRODUCT SEAKEEPER SERIES MODELS

Code 26/27/78/79/80

PROCEDURE

1. **IF** Code 26 or 27 on:
 - Seakeeper 9 (9-201-2839 thru 9-215-4164), **OR**
 - Seakeeper 18/16 (18/16-194-0001 thru 18-214-1067 or 16-213-0651)
 - **AND** 24V coil installed (see photo to right),

THEN REPLACE coil with 28V coil(s) (P/N 50379 or equivalent).

2. With multimeter in DC Volts mode, **MEASURE** voltage of DC INPUT supply connector to verify within specified range for unit.

Model DC Voltages

Seakeeper 2, 3, 5/6:	Operating Range 11-15VDC, 12VDC Nominal
Seakeeper 9 and 18/16:	Operating Range 22-32VDC, 24VDC Nominal (Serial ranges: 9-2839 or after, 18/16-0001 or after)
Seakeeper 9 through 40:	Operating Range 18-32VDC, 24VDC Nominal

- a. **IF** voltage unsatisfactory,
THEN TROUBLESHOOT vessel electrical.
3. **VERIFY** wire harness connectors at manifold are connected properly per labels.
4. **ACTIVATE** brake override.
5. **DISCONNECT** wire harness connector from coil of valve causing alarm.
6. **VERIFY** expected alarm code being diagnosed has set on display.



*24V coil shown.
Replace if found on
serial range listed.*



PRODUCT SEAKEEPER SERIES MODELS

Code 26/27/78/79/80

- With multimeter in DC Volts mode, **VERIFY** voltage between pins **1** and **2** (**A** and **C** for 26/35/40 Brake Valve) of the valve's wire harness connector is within 1 volt of DC INPUT supply voltage to wire harness from step 2.

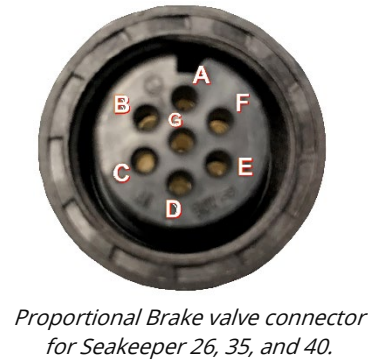
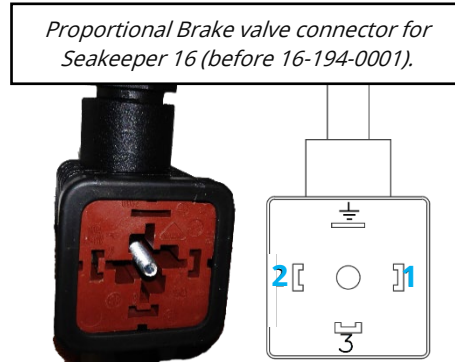

- IF** voltage SATISFACTORY and Codes 26, 27, 79, or 80, **THEN GO TO** [Section 1: Checking Coil](#).
- IF** voltage UNSATISFACTORY or Code 78, **THEN PROCEED** to [Section 2 Harness and GCM Checks](#)

SECTION 1: Checking Coil

- CHECK** resistance across all 2-way locking solenoid coils – NOT brake valve coil.



EXPECTED RELAY 2-WAY LOCKING COIL RESISTANCES				
MODEL	SERIAL RANGE	VOLTAGE	RESISTANCE (20°C*)	REPLACEMENT PART NO.
Seakeeper 2	ALL	12	5.2 – 6.4 Ω	50265
Seakeeper 3	3-0001 to 3-0171	12	5.9 – 6.9 Ω	50213
	3-0172 to 3-0561	12	5.9 – 6.9 Ω	50225
	3-0562 to current	12	5.2 – 6.4 Ω	50265
Seakeeper 3DC/5 (EM)	5-0001 to 5-0903	12	5.4 – 6.7 Ω	50198
Seakeeper 5 (EM)	5-0904 to 5-1049	12	5.2 – 6.4 Ω	50265
Seakeeper 6/5	6/5-0001 to 6/5-1935	12	5.2 – 6.4 Ω	50265
	6/5-1936 to current	12	7.8 – 9.6 Ω	50342
Seakeeper 9/7HD	9-0001 to 9-0798	24	22.5 – 27.5 Ω	50156
	9-0799 to 9-1325	24	19.1 – 23.5 Ω	50191
	9-1326 to 9-2838	24	20.7 – 25.5 Ω	50267
	9-2839 to current	28	20.1 – 22.3 Ω	50379
Seakeeper 16/12HD (EM)	ALL	24	19.1 – 23.5 Ω	50191
Seakeeper 18/16/12HD	18/16-0001 to current	28	20.1 – 22.3 Ω	50379
Seakeeper 26/20HD	ALL	24	22.5 – 27.5 Ω	50156
Seakeeper 35/30HD/40	ALL	24	22.5 – 27.5 Ω	50156

* Temperature can affect resistance and a good coil may test outside this band slightly.

- IF** coil resistance NOT in range of manufacturer's marking **OR** table, **THEN REPLACE** solenoid coil.
- IF** valve plug housing or coil shows signs of heat damage, **THEN REPLACE** solenoid coil.
- VERIFY** alarm clear.

SECTION 2: Harness and GCM Checks

Section 2A: Inspect Connector Integrity

1. In solenoid harness connector(s), **VERIFY** pins are fully inserted and wire crimps intact.
2. **IF** loose wires or crimps found, **THEN REPAIR** affected connector(s).
3. **PROCEED** to appropriate subsection for given Seakeeper model:

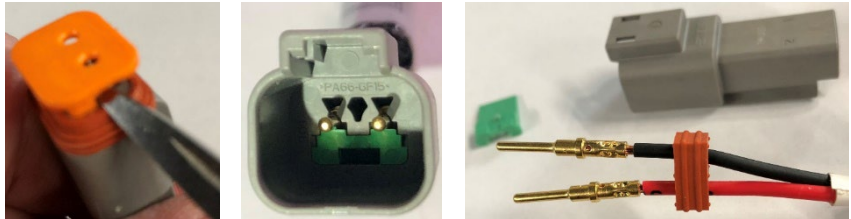

[Section 2B: Seakeeper 2 and 3](#)
[Section 2C: Seakeeper 5 and Above \(except for 26/20HD and 35/30HD/40\)](#)

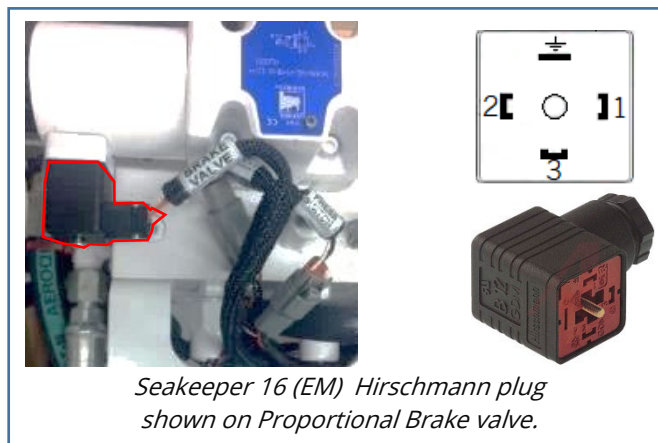

Seakeeper 16 (EM) Hirschmann plug shown on Proportional Brake valve.

Section 2B: Seakeeper 2 and 3

4. With multimeter in Resistance mode, **VERIFY** resistance 0.3Ω or less between following:
 - a. DC INPUT Power connector pin 1 and pin 1 of Brake or Lock Solenoid Connector being diagnosed.
 - b. Appropriate GCM pin below and pin 2 of Brake or Solenoid Connector being diagnosed.

- Code 26 - Solenoid 1: GCM pin 5 (shown below)
- Code 27 - Solenoid 2: GCM pin 9
- Code 78 - Brake Valve: GCM pin 11
- Code 79 - Solenoid 3: GCM pin 20
- Code 80 - Solenoid 4: GCM pin 23

5. **VERIFY** no short (Open Loop) between affected valve pin 1 and

- Code 26 - Solenoid 1: GCM pin 5.
- Code 27 - Solenoid 2: GCM pin 9
- Code 78 - Brake Valve: GCM pin 11
- Code 79 - Solenoid 3: GCM pin 20
- Code 80 - Solenoid 4: GCM pin 23

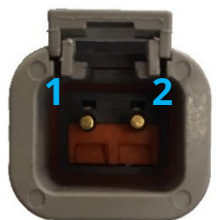

Harness Low Current DC INPUT Connector



GCM Connector

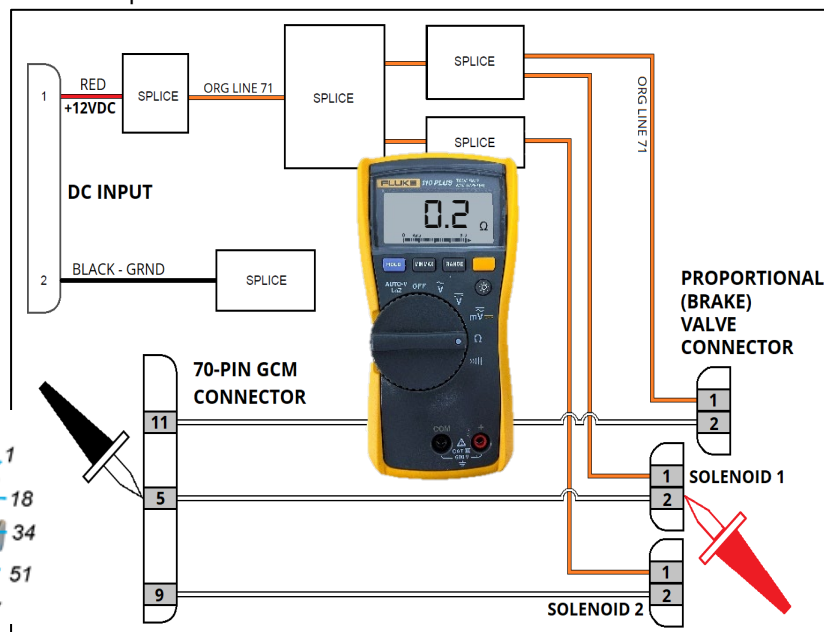

6. In GCM 70-pin connector, **VERIFY** pins are fully inserted and wire crimps intact.
 - a. **IF** loose wires or crimps found, **THEN REPAIR** affected wire(s).
7. **RECORD** findings **AND CONTINUE** to [SECTION 3](#).

Section 2C: Seakeeper 5 and up

8. **DISCONNECT** main power relay from harness.
9. With multimeter in Resistance mode, **VERIFY** resistance 0.3Ω or less between POWER RELAY pin **30** and pin **1** (pin **A** on Seakeeper 26, 35, & 40 prop valve) of Brake or Solenoid Connector being diagnosed.

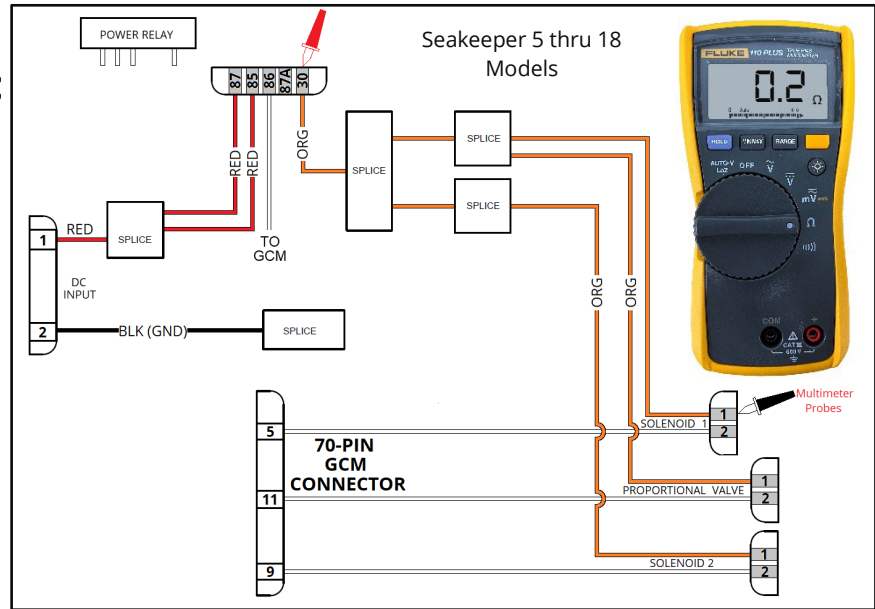
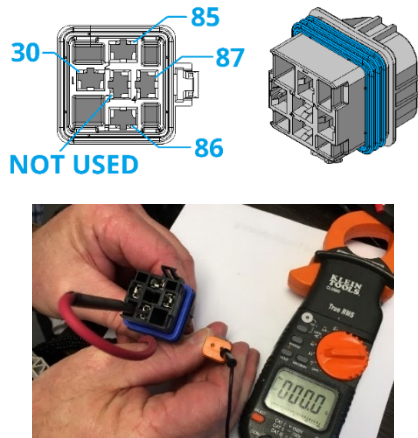

10. **CONFIRM** resistance 0.3Ω or less between appropriate GCM pin below and pin **2** of Brake or Solenoid Connector being diagnosed.

- | | |
|--------------------------------------------------|-------------------|
| Code 26 - Solenoid 1: | GCM pin 5 |
| Code 27 - Solenoid 2: | GCM pin 9 |
| Code 79 - Solenoid 3: | GCM pin 20 |
| Code 80 - Solenoid 4: | GCM pin 23 |
| Code 78 - Brake Valve: | GCM pin 11 |
| [N/A for Seakeeper 26, 35, & 40 which go to IMU] | |



Seakeeper 16/12HD(EM) valve connector



11. For Seakeeper 26/35/40 model brake valves (Code 78), **CHECK** harness resistances as follows:

a. **VERIFY** resistances 0.3Ω or less between following pins:

- i. Prop Valve pin **D** and IMU pin **7**.
- ii. Prop Valve pin **B, C, and E** and DC INPUT pin **2**.

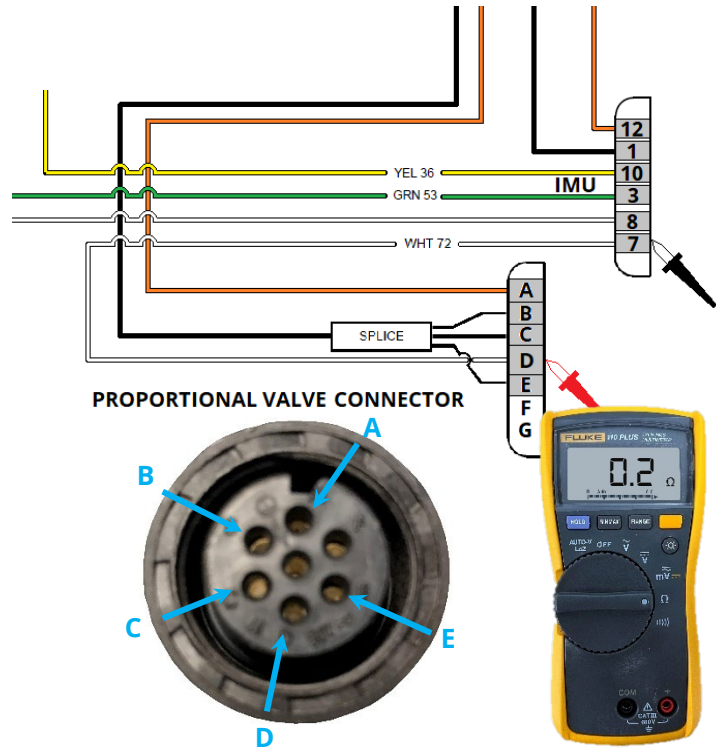
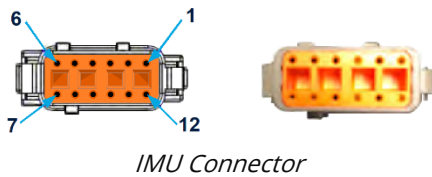

12. In GCM 70-pin connector, **VERIFY** pins are fully inserted and wire crimps intact.

a. **IF** loose wires or crimps found, **THEN REPAIR** affected wire(s).

13. **RECORD** findings.

14. **CONTINUE** to [SECTION 3](#).



SECTION 3

1. **IF** voltages were found UNSATISFACTORY in initial voltage checks and not Code 78, **THEN CHECK** affected solenoid coil per [SECTION 1](#).
2. **IF** harness tests of Section 2 UNSATISFACTORY, **THEN REPLACE** wire harness.
3. **IF** alarm persists, **THEN CONTACT** Seakeeper Product Support Team at support@seakeeper.com with required data, recorded test results, and summary of steps taken.

******* END *******

CODE 37/38/39

To troubleshoot and repair travel and motion fault alarms:

CODE 37: SEAKEEPER TRAVEL FAULT

CODE 38: SEAKEEPER MOTION FAULT

CODE 39: BRAKE TRAVEL FAULT (Seakeeper 2, 3, 5/3DC (EM), 5, 6, and 9/7HD only)

BACKGROUND

Continued operation with any of these codes may result in damage to equipment or injury. Power to the Seakeeper must be cycled to reset any of these alarms.

As the enclosure approaches the programmed end stop angles of the GCM software, a travel fault (Code 37) can be produced to warn the operator of abnormal operating conditions in the Seakeeper.

The motion fault (Code 38) can occur anywhere in the path of precession (it warns of an excessive precession rate) – not just near the end stops. It, too, is indicative of abnormal operations that will be addressed in this guide. It would not be unusual to see it accompany a Code 37.

The brake travel fault (Code 39) is produced in only Seakeeper 2, 3, 3DC/5(EM), 5/6, and 9/7HD models when the flywheel enclosure precesses at a rate higher than 50° per second at an angle over the software stop angle (varies with model: 55° - 67°).

Table with model and alarm setpoints:

Model	Alarm	Setpoint
Seakeeper 5 (EM) w/ Bump Stop	Code 37: Travel Fault	>50°/sec at >±55°
Seakeeper 5 (EM) w/o Bump Stop		>50°/sec at >±65°
Seakeeper 2 & 3		>100°/sec at >±67° *
Seakeeper 3 w/ small accumulator		>100°/sec at >±67°
Seakeeper 5/6 (all configurations)		>100°/sec at >±63°
Seakeeper 16 (EM)/12HD (EM)/26		>50°/sec at >±55°
All other Seakeeper models		>50°/sec at >±65° *
All Seakeeper Models	Code 38: Motion Fault	>150°/sec at any angle
Seakeeper 2, 3, 5 (EM), 5/6, 9/7HD	Code 39: Brake Travel Fault	>50°/sec at >±55°-67° ** & Brake Low Pressure on any switch

* The occurrence must be three times in a minute to produce the Code 37.

** Varies by model, ±55 – 67°

Experience has shown that many of these faults have been produced by brake system issues: low brake pressure, air in the brake system or the loosening of the rod end assembly at the gimbal. Beyond the brake system, the angle sensor or the GCM may also be at fault.

REFERENCES

[SWI-103 - Brake Service](#)

[SWI-108 - Angle Sensor Calibration](#)

[SWI-109 - Brake Bushing Replacement](#)

[SWI-111 - Seakeeper Cylinder Replacement](#)

Applicable Seakeeper Service Drawings

PRECAUTIONS

See [PRECAUTIONS](#) section in introduction.

PROCEDURE**Section 1: Initial Observations**

1. **ENSURE** flywheel at zero RPM at display/MFD app.
2. **ACTIVATE** brake override.
3. **CHECK** for hydraulic leaks:
 - a. **RUN** finger beneath each cylinder rod near seal to check for heavy oil film.



- b. **CHECK** cylinder hose fittings for oil film.
 - c. **CHECK** beneath brake manifold for indication of oil leak and below hose fittings.
4. **CHECK** threads of rod end of each cylinder for threads backing out as shown to right.



PRODUCT SEAKEEPER SERIES MODELS

Code 37/38/39

5. **ENSURE** all gimbal shaft screw yellow torque marks are aligned.
6. **CHECK** angle sensor wiring for sharp bends, pinching or damage.
7. **MANUALLY PRECESS** enclosure full forward and aft observing following:



- a. On display, two extreme angle readings should be within $\pm 1.0^\circ$ from
 - 70.0° Seakeeper **2** (ALL), **3** (3-0001 through 3-194-0959), **3DC/5(EM)** (without bump stop), **9/7HD** (ALL), **12HD/16/18** (ALL), and **35/30HD/40** (ALL)
 - 60.0° for Seakeeper **3DC/5(EM)** (with bump stop), **6/5** (ALL), **26** and **M-Series**
 - 58° for Seakeeper **3** (3-194-0960 and after)
- b. The two extremes (all way forward and all way aft) should be within 1.0° of each other. (For example, a -69.8° and a $+70.1^\circ$ would be satisfactory; the two are within $\pm 1.0^\circ$ of each other.
- c. **VERIFY** following faults do not exist:
 - excessive travel
 - enclosure failing to remain stationary at full forward or full aft
 - brake cylinder lateral movement
 - clicking sound from foundation or cylinder braces

8. **INSPECT** electrical connections at following for full engagement **AND** free of corrosion buildup:

- a. GCM 70-pin connector
- b. Angle Sensor connector to wire harness
- c. Manifold Proportional Valve
- d. IMU harness connector

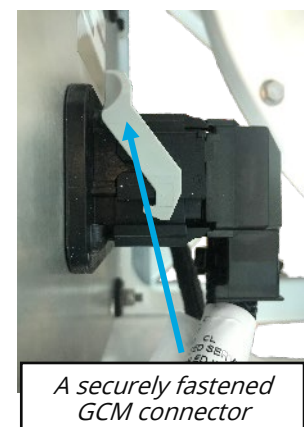
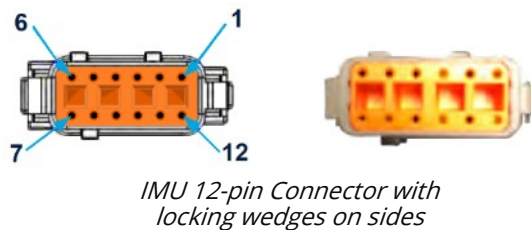
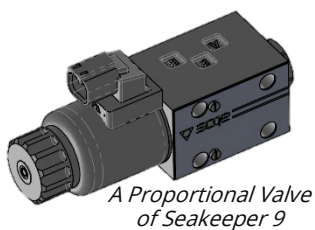

NOTE:

Some volume of air will be found in all brake systems.
Milky appearance and air bubbles are excessive volumes.

9. **ATTACH** brake service kit to Seakeeper per [SWI-103: Brake Service instruction](#):

- a. **NOTE** as found pressure: _____ **psi**
- b. **VENT** hydraulic fluid.
- c. **INSPECT** fluid for excessive foaming or air.

10. **APPLY** appropriate torque to Seakeeper mounting screws per torque Chart in [Section 6](#).

- a. **NOTE** any movement below torque specification.
- b. **NOTE** any damage to vessel foundation structure.
- c. **NOTE** excessive corrosion to mounting fasteners and hardware.

11. Using appropriate model Electrical Subsystem or Assembly drawing, **VERIFY** IMU mounted securely and in correct orientation.

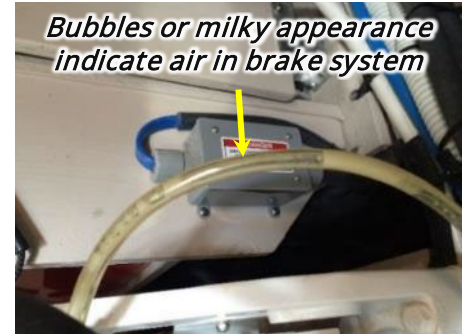

*Seakeeper 18/16 IMU shown
inside rear panel*

12. From inspections above, **DETERMINE** which sections to be used:
- a. **IF** cylinder rod seal leak was found in Step 3.a,
THEN PROCEED to [Section 3](#).
 - b. **IF** any manifold or hose fitting leak was found in Step 3.b or 3.c,
THEN PROCEED to [Section 2](#).
 - c. **IF** threads were backing out in Step 4 **OR** misalignment found **OR** issues in cylinders while precessing in Step 7, **OR** gimbal shaft screw torque marks not aligned in Step 5,
THEN PROCEED to [Section 3](#).
 - d. **IF** cylinder(s) were recently replaced,
THEN PROCEED to [Section 3](#).
 - e. **IF** issue was found with angle sensor in Steps 6 or 7,
THEN PROCEED to [Section 4](#).
 - f. **IF** electrical connection issue was seen in Step 8,
THEN PROCEED to [Section 5](#).
 - g. **IF** excessive air or low brake pressure (per table above) was seen in Step 9,
THEN:
 - i. **TEST** accumulator(s) per [Code 12/13/14 test](#).
 - ii. **IF** accumulator failed,
THEN REPLACE accumulator(s).
 - iii. **PERFORM** brake service per [SWI-103](#), to bleed all air from brake system.
 - iv. **PERFORM** sea trial afterward.
 - h. **IF** issues found in Step 10 (foundation and mounting hardware issues) above,
THEN PROCEED to [Section 6](#).
 - i. **IF NO** issues found in Section 1,
THEN PROCEED to [Section 7](#).



Section 2: Miscellaneous Hydraulic Leaks

1. **IF** hydraulic leak found on hose connection(s), **THEN PERFORM** following:
 - a. **IF** connection(s) covered in salt or corrosion, **THEN CLEAN** connection(s) with wire brush.

CAUTION:
Leakage may occur if hydraulic fitting is over-tightened.

- b. **TORQUE** hose connection(s) per table shown.

BRAKE HOSE FITTING TORQUES		
MODEL	TORQUE ft-lb (Nm)	WRENCH SIZE
Seakeeper 2 & 3	22 (29.8)	11/16"
Seakeeper 5 through 40	40 (54.2)	7/8"

- c. **PRESSURIZE** brake system per [SWI-103: Brake Service instructions](#).
 - d. **MONITOR** connection(s) for 10 minutes to ensure no leakage.
 - e. **REPLACE** affected hose(s) if leakage persists.
2. **IF** hydraulic leak(s) found on manifold of all other models, **THEN:**
 - a. **TIGHTEN** leaking component(s).
 - b. **REPLACE** affected component(s) if leakage persists.
3. **PERFORM** pressure test as follows:
 - a. **PRESSURIZE** brake system per [SWI-103 - Brake Service instructions](#).
 - b. **MONITOR** connection(s) for 10 minutes to ensure no leakage.
 - c. **REPLACE** affected component if leakage persists.

PRODUCT SEAKEEPER SERIES MODELS

4. **IF** other issues were found,
THEN PROCEED to relevant section(s) from [Section 1, step 12](#).

5. **IF** leaks repaired,
THEN PERFORM sea trial.

6. **IF** alarm returns,
THEN PROCEED [Section 7](#).

Section 3: Cylinder Issues

1. **IF** leak exists on brake cylinder,
THEN PERFORM cylinder replacement per [SWI-111 - Hydraulic Cylinder Replacement](#) instruction **AND COMPLETE** this section.
2. **IF** threads of rod end have backed out,
THEN:
 - a. **ACTIVATE** brake override.
 - b. **MANUALLY PRECESS** enclosure to gain wrench access to flats of rod.
 - c. **UNTHREAD** rod from rod-end clevis assembly.
 - **IF** excessive force is required to unthread rod and cross-threading suspected, **THEN REPLACE** cylinder per [SWI-111](#).
 - d. **CLEAN** rod threads and internal threads of rod-end clevis assembly.
 - e. **APPLY** red (high strength) thread lock fluid to threads of rod.
 - f. **COMPLETELY THREAD** rod back into rod-end clevis assembly.
3. **IF** unit's brake cylinder(s) were recently replaced,
THEN VERIFY correct hydraulic hose routing per applicable Brake Subsystem or Assembly drawing.

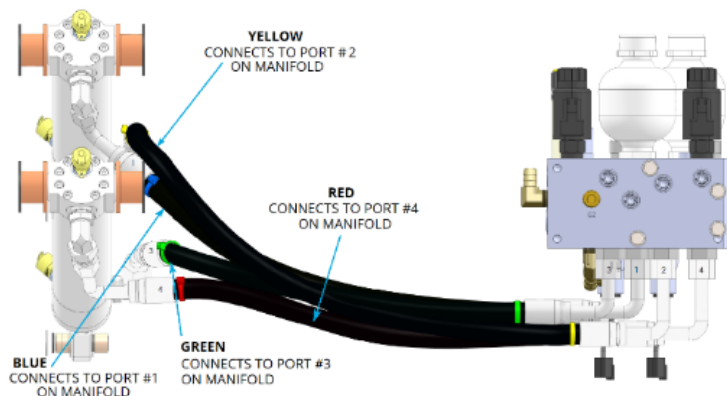
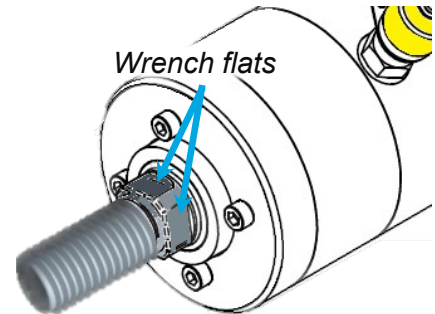

Seakeeper 5(EM) Shown

- a. **IF** hose routing is NOT correct,
THEN ROUTE hoses correctly per applicable Brake Subsystem or Assembly drawing.

Section 3, Step 3 continued

- b. **IF** hoses required rerouting,
THEN PERFORM thorough brake service per [SWI-103](#).
 - c. **IF** alarm returns,
THEN RETURN to [Section 1](#).
4. **IF** there is excessive travel, enclosure fails to remain stationary at full forward or full aft, there is lateral movement in cylinders **OR** there is clicking sound from foundation/cylinder braces, **THEN PERFORM** following:
- a. **LOOSEN** all associated cylinder brace mounting screws to hand-tight.
 - b. **PRECES** enclosure fully to align cylinder braces.
 - c. Once aligned, **WRENCH-TIGHTEN** corner fasteners.
 - d. One by one, **REMOVE** brace mounting screws.
 - e. **CLEAN** fasteners with wire brush.
 - f. **COAT** fasteners with Threadlocker.
 - g. **COAT** beneath washer with marine sealant,
 - h. **RE-INSERT AND TORQUE** all fasteners to required value per [Torque Specifications](#) section.
5. **IF** gimbal shaft screw torque marks not aligned,
THEN:
- a. **ENSURE** cylinder rods and rod ends are not damaged.
 - b. **REPLACE AND TORQUE** gimbal shaft screws per applicable Enclosure drawing.
6. **IF** other issues were found,
THEN PROCEED to appropriate section(s) of [Section 1, Step 12](#).
7. **IF** all work complete,
THEN PERFORM sea trial.
8. **IF** alarm returns,
THEN PROCEED to [Section 7](#).

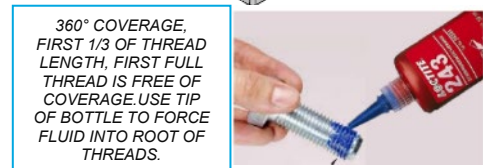
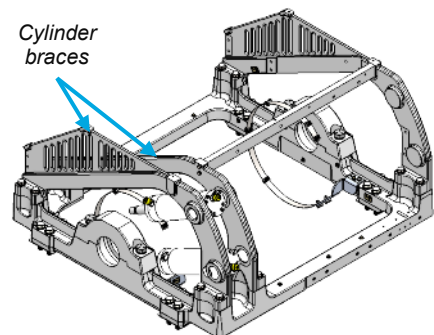

Sealant applied
beneath washer

Section 4: Angle Sensor Issues

1. **IF** wiring of angle sensor is issue (e.g., sharp bends, pinched leads, etc.),
THEN:

- a. **INSPECT** leads for damage.
- b. **REROUTE** wiring if no damage found.

2. **IF** angle sensor is out of calibration,
THEN CALIBRATE angle sensor per [SWI-108](#).

3. **PERFORM** following tests:

- a. **CONFIRM** 4.8 to 5.2VDC is available between pins **1** & **3** of angle sensor connector from harness.

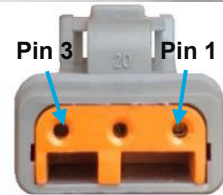
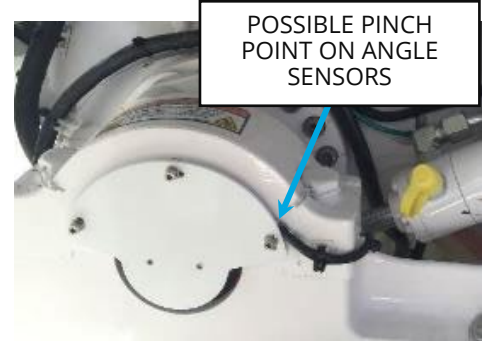

NOTE:

Voltages will vary with travel angles between different models.

- b. With angle sensor connected to wire harness, **MEASURE** voltage (by back-probing) between Pin **2** and Pin **3**, as shown.



Deutsch plug with back probes inserted into pins 2 & 3.



- At 0.0° precession, voltage should be about 2.5VDC
- At -70.0° precession, voltage should be about 4.25VDC. (travel angles vary)
- At +70.0° precession, voltage should be about 0.75VDC. (travel angles vary)

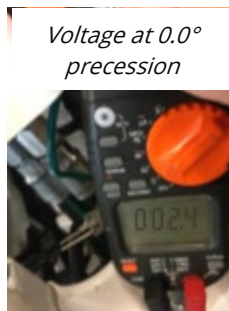

Section 4, Step 3 continued

- c. **IF** any voltages are out of range in step 3.b (more than 0.15VDC), **THEN:**
 - i. **REPLACE** angle sensor.
 - ii. **CALIBRATE** replacement sensor per [SWI-108](#)
 - d. **IF** angle sensor required recalibration/replacement, **THEN PERFORM** sea trial.
 - e. **IF** alarm returns, **THEN RETURN** to [Section 1](#).
4. **IF** angle sensor did NOT show 4.8 to 5.2VDC in Step 3.a of this section, **THEN PERFORM** following tests:
- a. **DEACTIVATE** brake override.
 - b. **REMOVE** low current DC power from Seakeeper.
 - c. **CONFIRM** 0.3Ω or less on angle sensor harness plug between pin **1** and GCM 70-pin connector pin **48**.

Angle Sensor Pin-Out:	
Pin 1 is +5VDC Supply	GCM pin 48
Pin 2 is signal voltage	GCM pin 28
Pin 3 is GND	Curtis Drive "B-" terminal (Seakeeper 1)
	GCM pin 2 (Seakeeper 3, 5/3DC (EM), and 6/5)
	GCM pin 32 (all other models)

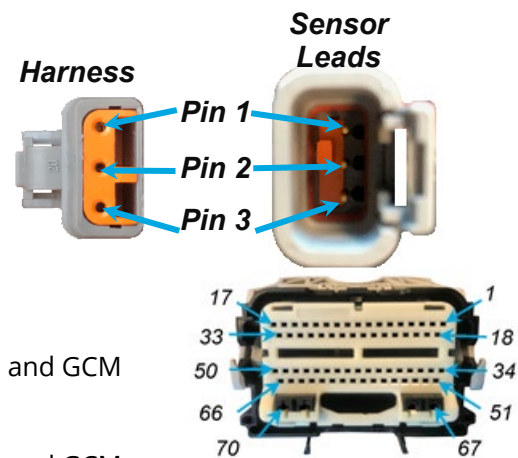

- d. **CONFIRM** 0.3Ω or less on harness plug between pin **2** and GCM 70-pin connector pin **28**.
- e. **CONFIRM** 0.3Ω or less on harness plug between pin **3** and GCM 70-pin connector pin **2** (for Seakeeper 3 thru 6), pin **32** (on Seakeeper 2 & 9 or above).
- f. **IF** any test in Step 4.c through 4.e of this section showed high or intermittent resistance (open), **THEN REPLACE** wire harness.
- g. **IF** resistances satisfactory in harness but 5VDC was NOT seen, **THEN REPLACE** GCM.

Section 4, Step 4 continued

- h. **RECONNECT** angle sensor to wire harness.
 - i. **RESTORE** low current DC power to Seakeeper.
5. **IF** other issues were found,
THEN PROCEED to relevant section(s) of [Section 1, Step 12](#).
6. **IF** all work complete,
THEN PERFORM sea trial.
7. **IF** alarm persists,
THEN GO TO [Section 7](#).

Section 5: Electrical Connection Issues

1. **IF** any of following connectors are loose, corroded or damaged,
 - GCM 70-pin connector
 - Angle Sensor connector to wire harness
 - Manifold Brake/Proportional Valve
 - IMU harness connector

THEN REMOVE all power from Seakeeper.

2. **DISCONNECT** connector(s) affected.
3. **DISASSEMBLE AND CLOSELY INSPECT** associated connector(s) pins and sockets for loose or missing connections.

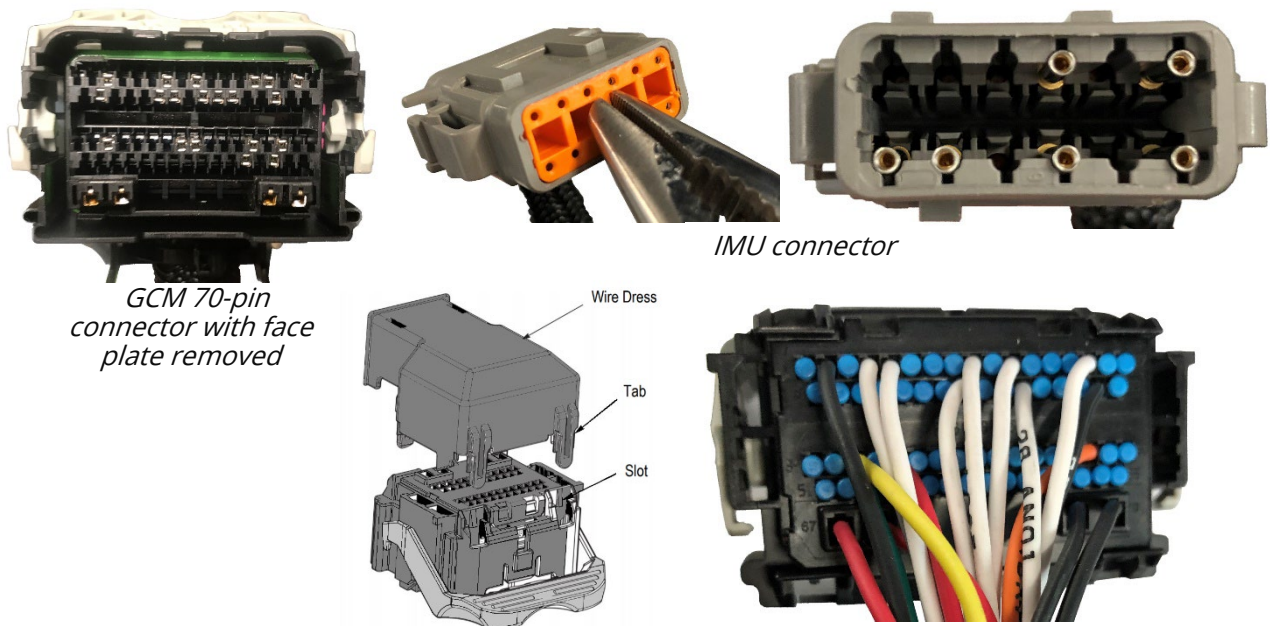

4. **IF** associated connector(s) corroded, **THEN CLEAN** connectors with contact cleaner and/or wipe all corrosion with clean rag.
5. **IF** angle sensor wiring affected, **THEN PERFORM** [Section 4, Step 4](#) tests of wire harness and sensor leads.

6. **PERFORM** following:

a. **IF** Seakeeper 2 through 9/7HD or 18/16/12HD (18/16-194-0001 or later), **THEN PERFORM** following:

- i. **REMOVE** low-current DC power.
- ii. **DISCONNECT** GCM 70-pin connector.
- iii. **CONFIRM** 0.3Ω or less between pin 2 and GCM pin 11.
- iv. **CHECK** for short between pin 1 and GCM pin 11.
- v. **RESTORE** low-current DC power.
- vi. **ACTIVATE** brake override.
- vii. **MEASURE** for 12/24VDC across proportional valve connector of harness, per table shown above.
- viii. **IF** high resistance is seen in Step 6.a.iii **OR** resistance other than OPEN LOOP seen in Step 6.a.iv, **THEN:**
 - 1. **DISASSEMBLE AND INSPECT** connectors for corrosion, loose or disconnected crimps.
 - 2. **IF** connectors SATISFACTORY, **THEN REPLACE** wire harness.
- ix. **IF** checks of Steps 6.a.iii through 6.a.iv **AND** voltage in Step 6.a.vii are SATISFACTORY **AND** alarm persists, **THEN PROCEED** to [Step 7 of this section](#).

Proportional Valve to GCM Pin-out	
Seakeeper 2, 3, 5, 6/5HD.....	12 Volts
Seakeeper 9/7HD, 16/18/12HD.....	24 Volts
Pin 1 =	12/24v+ from Line 71 (Orange wire)
Pin 2 =	GCM pin 11 (White wire)

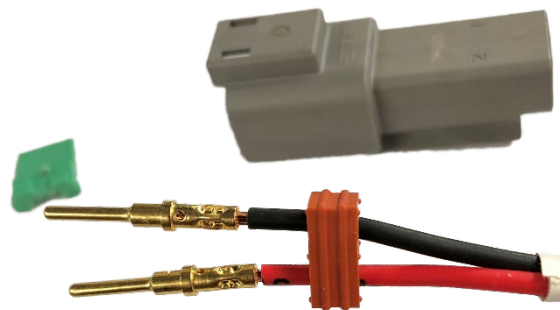
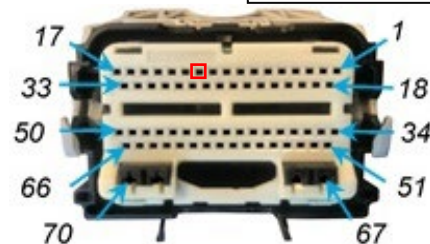
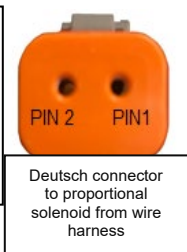

Section 5, Step 6 continued

- b. **IF** Seakeeper 16/12HD (EM),
THEN PERFORM following:

- i. **REMOVE** DC power.
- ii. **DISCONNECT** GCM 70-pin connector.



Seakeeper 16 Hirschmann plug
shown on proportional valve

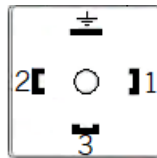

HIRSCHMANN GDMZ RB 29 0 316 0
or GDM 2009 J BLACK

Pin 1 = Line 71 +24VDC (*orange wire*)
Pin 2 = GCM pin 11 (*white wire*)
Pin 3 = NOT USED
GND = NOT USED



- iii. **ENSURE** 0.3Ω or less between pin **2** and GCM pin **11**.
- iv. **CHECK** for short between pin **1** and GCM pin **11**.
- v. **RESTORE** DC power.
- vi. **ACTIVATE** brake override.
- vii. **MEASURE** voltage across pin **1** and pin **2** of wire harness connector to proportional valve for 24VDC.
- viii. **IF** high resistance is seen in Step 6.b.iii **OR** resistance other than OPEN LOOP seen in Step 6.b.iv,
THEN REPLACE wire harness.
- ix. **IF** checks of Steps 6.b.iii, 6.b.iv and 6.b.vii are SATISFACTORY **AND** alarm persists,
THEN PROCEED to [Step 7 of this section](#).

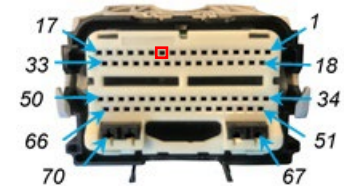

Section 5, Step 6 continued

- c. **IF** Seakeeper 26/20HD, 35/30HD, or 40, **THEN PERFORM** following:

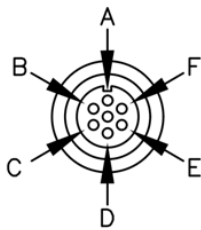

Pin A: 71 (+24VDC) *(Orange Wire)*
 Pin B: Ground B1 *(Black Wire)*
 Pin C: Ground B1 *(Black Wire)*
 Pin D: 72 SVCMD to IMU Pin 7 *(White Wire)*
 Pin E: Ground B1 *(Black Wire)*
 Pin F: Not Used
 Pin G (Center): Not Used
Pins B, C & E are connected and should have low/no resistance between them



- i. **REMOVE** DC power.
- ii. **DISCONNECT** IMU harness connector.
- iii. **CONFIRM** 0.3Ω or less between pin **D** and IMU connector pin **7**.
- iv. **CONFIRM** 0.3Ω or less between IMU pin **8** and GCM pin **21**.
- v. **TEST** for short between pin **B, C** or **E** and IMU pin **7**.
- vi. **RESTORE** DC power.
- vii. **ACTIVATE** brake override.

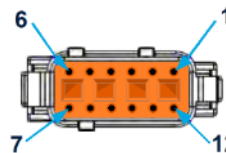

Deutsch DTM06-12SA (FEMALE)

NOTE:

- Any voltage seen may be below normal control power voltage due to signal produced for conditions.
- Pins can be accessed through loosening of clamp nut on back side of plug as shown to right.

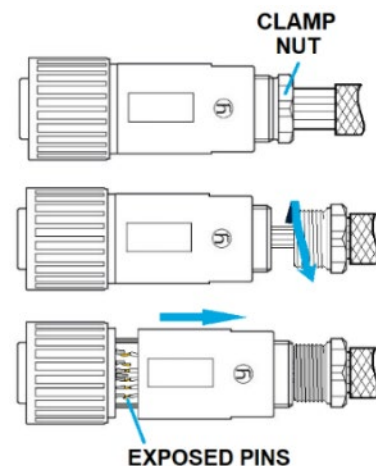

- viii. **MEASURE** voltage between pin **A** and pin **B** for 24VDC.
- ix. **MEASURE** voltage between pin **A** and pin **C** for 24VDC.

Section 5, Step 6.c continued

- x. **MEASURE** voltage between pin **A** and Pin **E** for 24VDC.

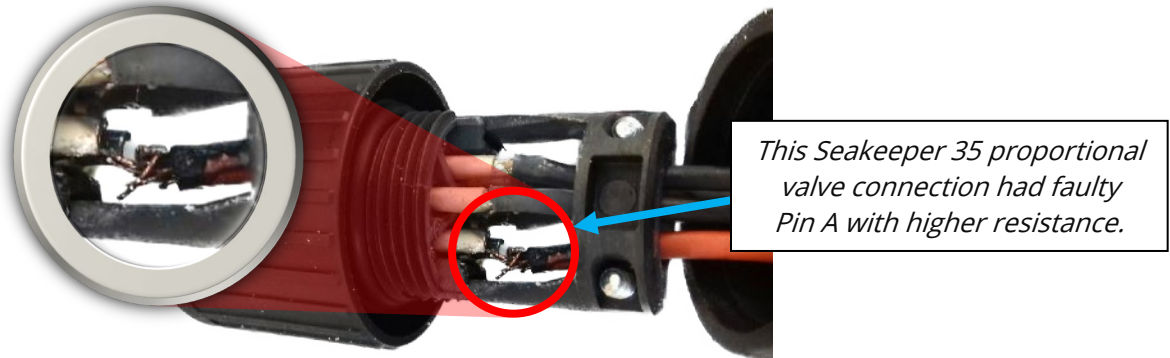

- xi. With brake valve connected to harness **AND** brake override activated, **ENSURE** some voltage exists between pin **C** and pin **D**.
- xii. **IF** no voltage was seen in Step 6.c.ix through 6.c.xi above **AND** tests of Steps 6.c.iii through 6.c.vi were SATISFACTORY, **THEN REPLACE** IMU.

1. **IF** IMU is revision 1 (larger) IMU, **THEN CONTACT** Seakeeper Product Support Team at support@seakeeper.com for instructions.

Revision 1 IMU

- xiii. **IF:**
- voltage was **not** seen in Steps 6.c.viii through 6.c.xi above **OR**
 - no continuity exists in Step 6.c.iii or 6.c.iv **OR**
 - short was seen in Step 6.c.v,
- THEN REPLACE** wire harness.

PRODUCT SEAKEEPER SERIES MODELS

Code 37/38/39

7. **PERFORM** following test to check manifold valve integrity:
 - a. **REMOVE** coil from proportional brake valve.
 - b. **ACTIVATE** brake override.
 - c. **ATTEMPT** manual precession in both directions.
 - d. **IF** sphere moved in either direction with brake valve coil removed,
THEN CONTACT Seakeeper Product Support Team about possible replacing manifold.
8. **IF** other issues found,
THEN PROCEED to appropriate section(s).
9. **IF** all work complete,
THEN PERFORM sea trial.
10. **IF** alarm persists,
THEN:
 - a. **OBTAIN** photo of display/MFD app Information screen.

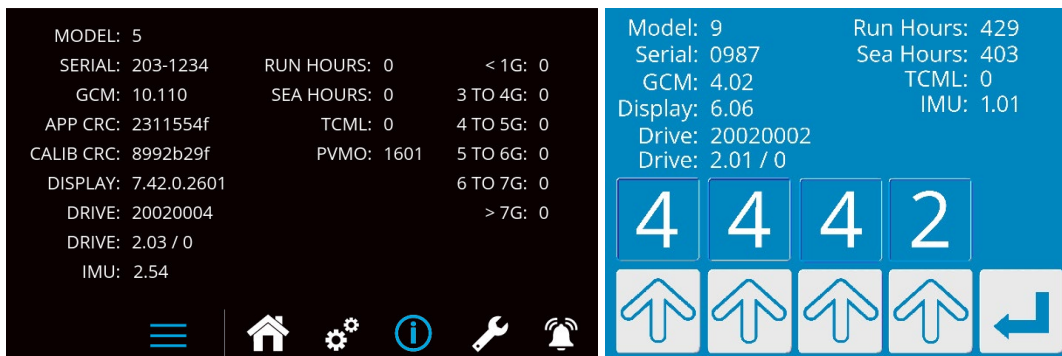

- b. **SUBMIT** photo to Seakeeper Product Support Team for software version evaluation with test results from troubleshooting.
- c. **PROCEED** to [Section 7](#).

Section 6: Bolt-In Mounting Issues

TORQUE SPECIFICATION CHART				
Seakeeper 2 & 3		Seakeeper 5/3DC & 5/6		Seakeeper 9/7HD through 40 all models
2 (ALL) 3-0001 - 3-3835	3-3836 & up	5/3DC (ALL) 5/6-0001 - 5/6-5364	5/6-5365 & up	100 ft-lb 136 Nm
135 ft-lb 183 Nm	155 ft-lbs 210 Nm	65 ft-lb 88 Nm	95 ft-lbs 129 Nm	

NOTE:

- Mounting fasteners are NOT to be re-used once removed.
- On through-bolt installations, it may be difficult to see or wrench nut.
- Aluminum backing plates (tapping plates) **MUST** have thread inserts installed.

1. **IF** torque discovered on any mounting screw was below specification, **THEN ATTEMPT** to torque mounting screw(s) to appropriate torque.
2. **IF** screw turns before obtaining torque, **THEN:**
 - a. **REMOVE** fastener(s).
 - b. **INSPECT** mounting hole for possible thread insert damage or backing plate thread damage.



Thread insert in this installation was damaged and thread remains were pulled easily from hole.

PRODUCT SEAKEEPER SERIES MODELS

Code 37/38/39

3. **IF** excessive corrosion is found on mounting fasteners and hardware,
THEN REPLACE hardware with new bolt-in kit for model
(Visit [Seakeeper Partner Center](#) for proper kit).
4. **INSPECT** stringer and foundation structure for cracking, flexing, or delamination. (This will require a sea trial with Seakeeper operation)
5. **IF** no other issue is suspected,
THEN PERFORM sea trial to verify alarm clear.
6. **IF** all mounting issues are addressed **AND** alarm persists,
THEN CONTINUE to [Section 7](#).
7. **IF** other issues were found,
THEN RETURN TO [Section 1](#) to be directed to appropriate section to address issues.



Section 7: Other Issues

1. **PERFORM** following on Bi-Directional manifolds:
 - a. **CHECK** if accumulators have check valve adapter installed. (Only on AFS bi-directional manifolds)
 - b. **IF** check valve adapters installed, **THEN VERIFY** adapter arrow points toward manifold as shown.
 - c. **INSTALL** brake service kit **AND REMOVE** pressure from brake system.
 - d. **REMOVE** accumulator/check valve adapter assembly.

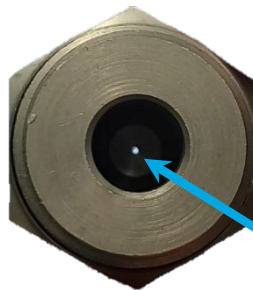
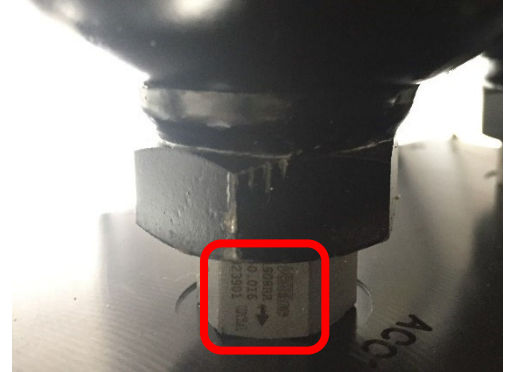

Should be able to see light through orifice

- e. **INSPECT** check valve adapter for clear passages **AND** proper operation.
 - f. **REINSTALL** accumulator/check valve adapter assembly.
 - g. **THOROUGHLY VENT** brake system per [SWI-103](#).
 - h. **REPRESSURIZE** brake system.
2. **IF** submitted photo of Information screen showed improper software versions (from Section 5, Step 9), **THEN REPROGRAM / REPLACE** GCM.
3. **IF** GCM recently reprogrammed or replaced, **THEN CONTACT** Seakeeper Product Support Team. [proportional valves require pairing with GCM]
4. **PERFORM** sea trial **AND LOG** CAN data using Seakeeper Service Tool per [SWI-118](#).
5. **IF** alarm persists, **THEN SUBMIT** all test results data and photos from complete troubleshooting to Seakeeper Product Support Team at support@seakeeper.com.

******* END *******

CODE 115

To troubleshoot and repair the “PROP VALVE CURRENT HIGH IN LOCK” alarm (Code 115).

BACKGROUND

The Seakeeper 2 and 3 (after S/N 3-0561) are equipped with rectified brake electrical systems that maintain a current through the proportional valve (prop valve) when in the “LOCKED” mode of operation. The purpose of this small current is to keep the solenoid warm for operation when the operator takes the system to “UNLOCKED” or “SEA” mode. Code 115 was programmed into the GCM's software to alert the operator of an abnormal current in this warming circuitry.

The code will appear on the display when the current to the proportional valve coil exceeds 1.47 amps (1467 mA) for 1 second. The code will clear once the current is below 0.75 amps (750 mA). The code would only occur during spool-up, while the Seakeeper is LOCKED.

There are three faults that could cause the alarm:

1. A short in the wiring to the proportional valve,
2. A GCM failure,
3. The proportional valve is physically jammed from foreign material or failure.

Each cause is addressed here.

PRECAUTIONS

See [PRECAUTIONS](#) section in introduction.

PROCEDURE

1. **VERIFY** all electrical connections to manifold solenoids and GCM are made securely.
2. **CHECK** labels of harness connectors correspond to appropriate device.
3. **ENSURE** coil is secured to proportional valve by checking threaded coil retaining caps tight.
4. **TURN OFF** all DC power to Seakeeper.
5. **TEST** proportional valve per following:



- a. **DISCONNECT** GCM 70-pin connector.
- b. **TEST** resistance 0.3Ω or less between pin 2 of prop valve connector and GCM pin 11.

Resistances are stamped in sides of coils and measured between pins of coil:

Seakeeper 2 & 3.....12 Volts

Pin 1 = 12v+ Orange wire

Pin 2 = GCM pin 11 (White wire)

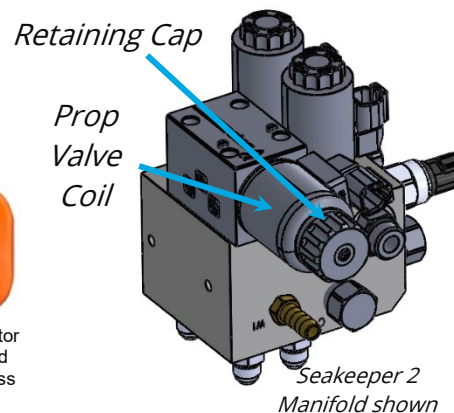

- c. **VERIFY** no short between pin 1 of prop valve connector and GCM pin 11.
- d. **RECONNECT** all harness connectors.
- e. **RESTORE** low current DC power.
- f. **ACTIVATE** brake override.
- g. **ENSURE** manual precession is available.

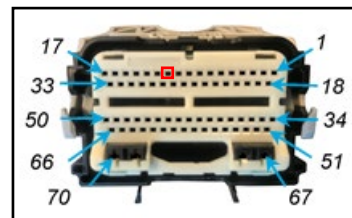



Step 5 continued

h. **USE** decision table to decide remedy steps:

CONDITION	REPLACE WIRE HARNESS	GO TO BRAKE OVERRIDE INOPERABLE SECTION	GO TO STEP 6
Step 5.b resistance high (greater than 0.3Ω)	✓		
Step 5.c has low resistance (short)	✓		
Step 5.g manual precession NOT available		✓	
Checks of Step 5 were SATISFACTORY			✓

6. **IF** alarm persists,
THEN:

- a. **LOG** CAN data using Seakeeper Service Tool app per [SWI-118](#) with alarm active.
- b. **CONTACT** Seakeeper Product Support Team at support@seakeeper.com with all data collected from testing.

******* END *******

BRAKE OVERRIDE INOPERABLE



To troubleshoot and repair the inability to engage Brake Override from the display(s)/MFD app.

BACKGROUND

This procedure assumes there are no alarms on the display; this issue's symptom is only the inability to precess the enclosure with the override engaged manually. If an alarm is active, address it first per SWI-106, TROUBLESHOOTING GUIDE. **No override is available if the flywheel is rotating**; verify the flywheel RPM has reached zero before attempting to engage any override. One should see the following displays if the overrides are unavailable:

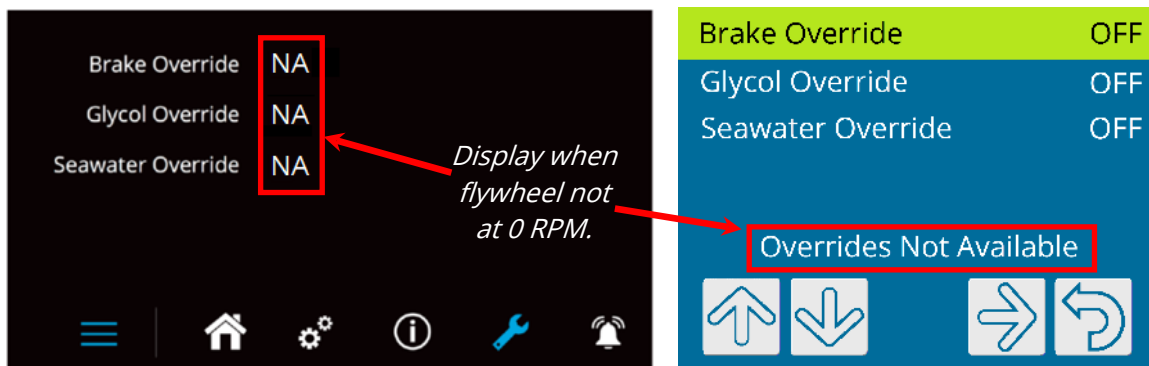

When the flywheel is at rest and the brake override activated, a clicking sound should be heard at the stabilizer from the manifold solenoids activating. If this sound is not heard, attention should be given to the electrical troubleshooting of connections and wiring harness integrity.

If imperative to continue maintenance requiring the enclosure to be precessed manually, this can be accomplished by completely venting all pressure in the brake system from all service ports. After maintenance, re-pressurize the brake system per the SWI-103: Brake Service instruction. This action will produce a low brake pressure alarm at the display that will require resetting.

If the model in question is equipped with a rectified brake manifold, it will resist manual precession due to design. It may be necessary to use mechanical advantage to precess a sphere manually.

REFERENCES

Applicable Seakeeper Service Drawings on [Dealer Access](#)

[SWI-103 - Brake Service Instruction](#)

PRECAUTIONS

See [PRECAUTIONS](#) section in introduction.

PROCEDURE

1. **VERIFY** display functional:
 - a. **ENSURE** 5" touch display functionality by activating Glycol Override.
 - b. **ENSURE** 3.5" display buttons functioning correctly.
 - c. **CYCLE** DC power to Seakeeper.
 - d. **IF** any issues found in display, **THEN CONNECT** a similar display at Seakeeper **AND ACTIVATE** brake override.

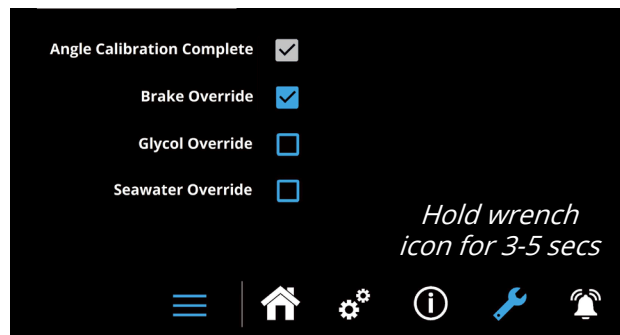
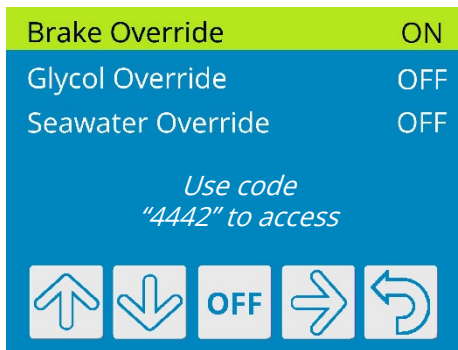

- e. **IF** enclosure can now be manually precessed, **THEN REPLACE** helm display.
2. **VERIFY** all electrical connections to manifold solenoids, display, and GCM are made securely.



An example of brake solenoid assembly



A properly connected GCM 70-pin connector

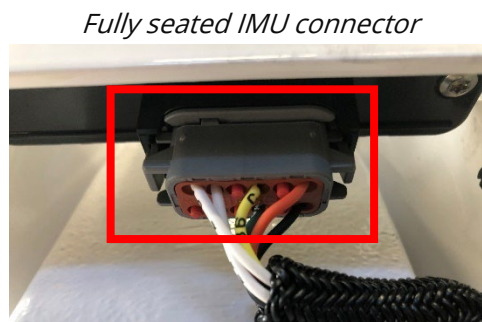

3. **IF** Seakeeper 26/20HD, 35/30HD or 40, **THEN CHECK** connection at IMU.
4. **CHECK** labels of harness connectors correspond to appropriate devices.

PRODUCT SEAKEEPER SERIES MODELS

Brake Override Inop.

5. **ENSURE** DC supply voltage in normal range:
 - a. **DISCONNECT** DC INPUT connector.
 - b. On vessel supply connector, **VERIFY** DC voltage within 0.6VDC of battery voltage.
 - c. **VERIFY** DC voltage 11-15VDC (12V system) or 22-32VDC (24V system).
- 
- Example of harness label for Proportional valve*
6. **ENSURE** display/MFD app Service screen does NOT show "1234 RPM."
 - a. **IF** this Motor Drive fault is seen, **THEN REPLACE** Motor Drive Box.
 7. **IF** no sound heard locally at manifold **OR** solenoids do NOT become warm when brake override activated, **THEN CHECK** manifold solenoids per [Code 26, 27, 78, 79, and 80](#) Troubleshooting Guide.
 8. **IF** solenoids energize and only limited manual precession is allowed, **THEN CHECK** for freedom of movement of enclosure and guide bands.
 9. **IF** manual precession required for other maintenance, **THEN:**
 - a. **VENT** brake system per [SWI-103](#).
 - b. **MAINTAIN** cylinder vents attached and opened to precess enclosure, as desired.
 - c. **VENT AND RESTORE** brake system pressure per SWI-103 once maintenance completed.
 10. **IF** brake override remains inoperable, **THEN CONTACT** Seakeeper Product Support Team at support@seakeeper.com with summary of all actions taken and results of troubleshooting tests.

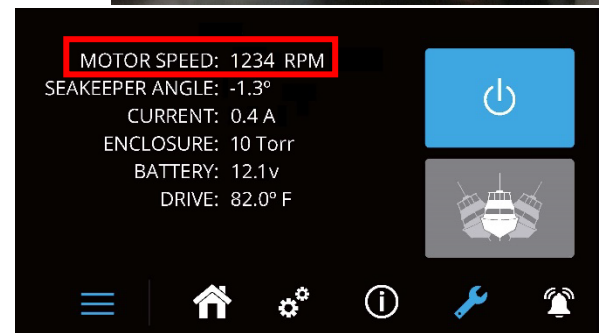
***** **END** *****

PRODUCT SEAKEEPER SERIES MODELS

CODE 6/104/157

To troubleshoot and repair the following:

- DRIVE TEMP HIGH alarm (Code 6)
- DRIVE TEMPERATURE alarm (Code 104)
- DRIVE TEMPERATURE warning (Code 157)

BACKGROUND

Code 6 is triggered when the motor drive box (MDB) temperature exceeds the setpoint of 65°C/149°F (70°C/158°F in DC-powered models) in the Seakeeper controller to initiate lock and coasting of the stabilizer. The alarm can be reset when drive temperature drops below 60°C/140°F (65°C/149°F in DC-powered models).

Upon activation of a Code 6, the Seakeeper will lock, and coast the flywheel. If the drive temperature continues to rise and exceeds a threshold set in the drive's software, it would trigger Code 104. The higher temperature may drive further action to reduce or eliminate power consumption to reduce its heat.

Code 157 is enabled in AC-powered models as a warning when temperature in the MDB approaches the Code 6 set point. The Seakeeper will continue to operate when this warning is triggered but may not appear on display to operator. It will, however, be logged in alarm history.

Several conditions can cause a high drive temperature: seawater supply failures, glycol coolant loop failures, or electrical failures. Bearing high-temperature alarm(s) or "Coolant Pump Fault" may also be in alarm history.

The glycol coolant system is shipped with a 50/50 Ethylene Glycol and distilled water mixture. If a different type of antifreeze liquid desired, a full system flush is required first. When glycol types are mixed, they can cause blockage of coolant paths and lead to high operating temperatures.

Pod drives and large outboards with the station-keeping capability and/or joystick operation may cause an air-locked seawater pump. Additionally, clogged seawater strainers or impellers will restrict flow resulting in a high drive temperature. These possible causes should be kept in mind when troubleshooting temperature alarms.

TEMPERATURE ALARM SETPOINTS	
COMPONENT	SETPOINT
MDB (AC-POWERED MODELS)	65°C / 149°F
MDB (DC-POWERED MODELS)	70°C / 158°F
FLYWHEEL BEARINGS*	70°C / 158°F

MDB: Motor Drive Box

The run times of a seawater pump after the Seakeeper is turned off will vary with the GCM programming. Some models' pump may run for 10 minutes, while other pumps will secure with the flywheel motor. If the Seakeeper secured and restarted within a short time, the time for heat dissipation may be inadequate to prevent a Code 6 or 104. Ensure operators understand that for short durations, it is better to place the Seakeeper in "LOCK" mode than to secure its operation.

Many new models use an on-demand seawater pump. These models accommodate a DC-powered seawater pump. The motor drive temperature set point for seawater pump start and stop varies between models, as shown in the following table:

MODEL	SERIAL RANGE	Drive temperature set points for seawater pump (Start / Stop)
Seakeeper 2*	2-0001 to 2-194-0249	55°C / 50°C
	2-194-0250 to current	52°C / 50°C
Seakeeper 3**	3-0001 to current	55°C / 50°C
Seakeeper 6/5	6/5-211-2771 to current	55°C / 50°C
Seakeeper 9/7HD	9-212-3388 to current	48°C / 46°C
Seakeeper 18/16/12HD	18/16/12HD-194-0001 to current	55°C / 50°C
Seakeeper 40	ALL	58°C / 56°C
* Seakeeper 2 received a discrete seawater relay on 2-203-0400		
** Seakeeper 3 received a discrete seawater relay on 3-203-1425		

For AC-powered models, begin troubleshooting in [Section 1](#).

For DC-powered models, begin troubleshooting in [Section 2](#).

REFERENCES

Applicable Seakeeper Service Drawings

Applicable Seakeeper Cooling Water Schematic

[SWI-107 - Seakeeper Glycol Flush work instruction](#)

PRECAUTIONS

See [PRECAUTIONS](#) section of Introduction.

PROCEDURE

SECTION 1: AC-POWERED MODELS

NOTE:

- If DC-powered model or late model Seakeeper 6 through 9, unit’s seawater pump will only run within specific MDB temperature range; Seawater Override may need to be activated.
- If boat is out of the water, using Seawater Override to electrically rotate seawater pump for less than 10 seconds should be acceptable for both AC & DC-powered models. Ensure an observer is local to pump to ensure it rotates.

1. **ACTIVATE** Seawater Override.

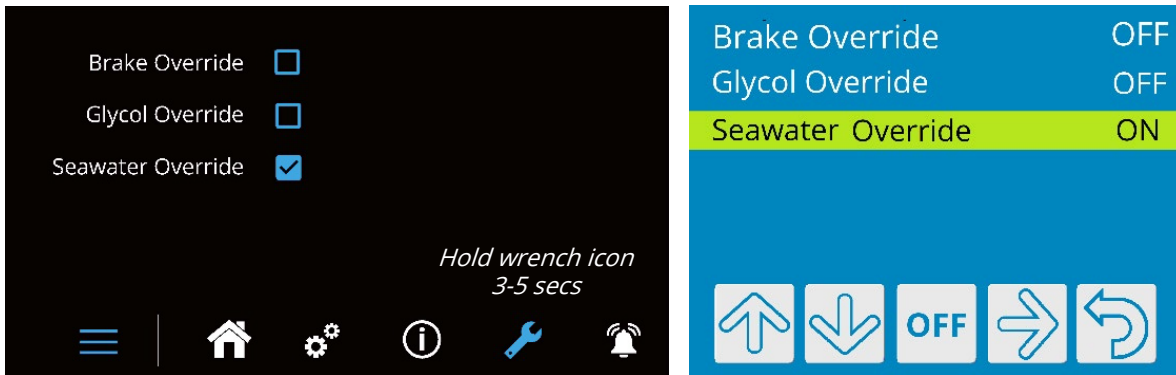



2. **IF** seawater pump running with override, **THEN PROCEED** to [Section 1, Step 5](#).
3. **IF** seawater pump NOT running with override, **THEN:**
 - a. **DETERMINE** power alignment of seawater pump.

The following model and serial ranges use DC-powered seawater pumps powered by Seakeeper-supplied seawater pump relays:

Seakeeper 6/5 (6/5-211-2771 through current)
 Seakeeper 9/7HD (9-212-3388 through current)
 Seakeeper 18/16/12HD (18/16/12HD-194-0001 through current)
 Seakeeper 40 (ALL)

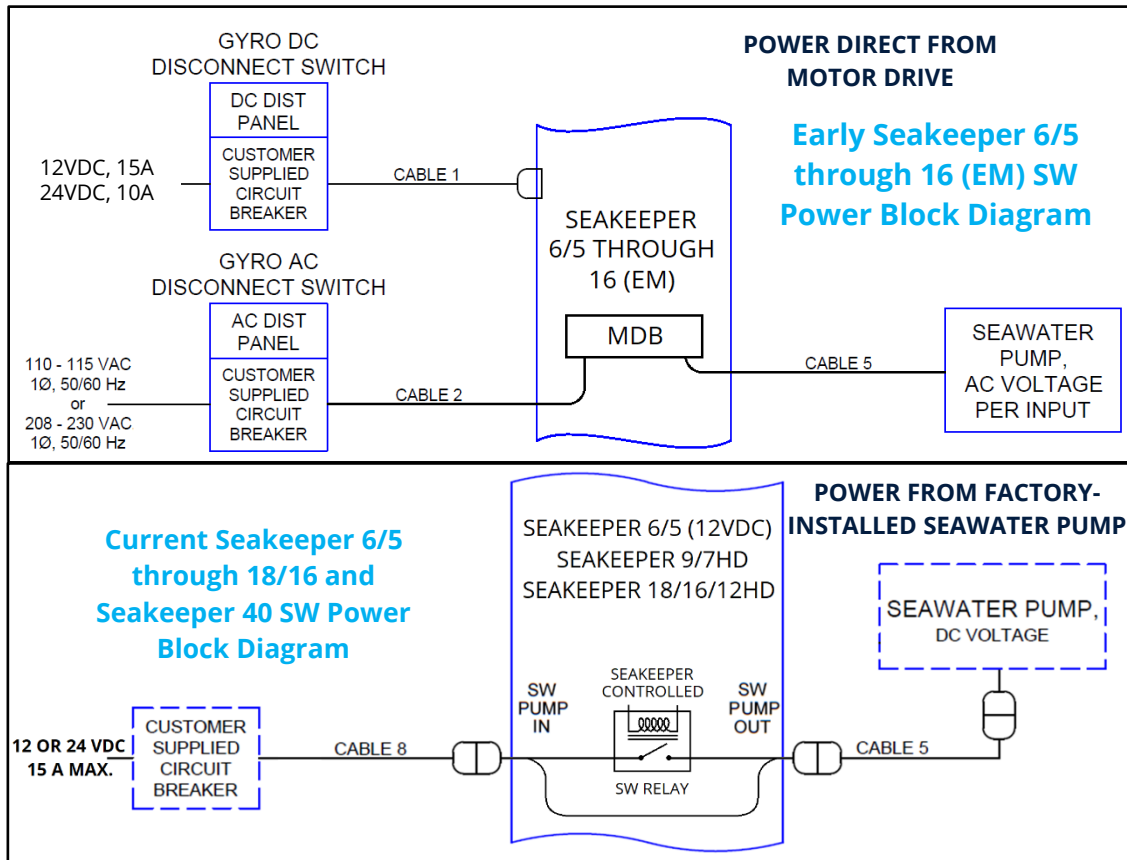
Section 1, Step 3.a continued





WARNING!

SHOCK HAZARD EXISTS INSIDE
MDB WHEN FLYWHEEL ROTATING OR POWER APPLIED.

- b. **IF** seawater pump powered directly from MDB (AC seawater pump), **THEN:**
 - i. **TURN OFF** AC supply breaker to Seakeeper.
 - ii. **ENSURE** flywheel at zero RPM at display/MFD app.
 - iii. **OPEN** MDB cover.
 - iv. **REMOVE** seawater pump leads at SW PUMP terminal.
 - v. **RESTORE** AC power to Seakeeper.
 - vi. **ACTIVATE** seawater override.

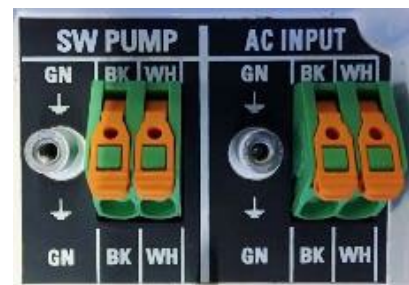

PRODUCT SEAKEEPER SERIES MODELS

Code 6/104/157

Section 1, Step 3.b continued

- vii. With multimeter in AC Voltage mode, **CHECK** voltage at SW PUMP terminal matches AC INPUT terminal voltage.

Voltage: _____ VAC

- viii. **DEACTIVATE** seawater override.
- ix. **REINSERT** seawater pump leads at SW PUMP terminal.
- x. **ACTIVATE** seawater override.
- xi. **TEST** for voltage at seawater pump motor.
- xii. **IF** voltage NOT present at pump motor but was present at SW PUMP terminal in Step 3.b.vi,
THEN TEST continuity of seawater pump cable.
- xiii. **IF** continuity NOT present,
THEN REPLACE seawater pump cable.
- xiv. **IF** both locations show proper voltage,
THEN REPLACE Seawater Pump.
- xv. **IF** voltage is not present at MDB SW PUMP posts **OR** is much lower than AC INPUT terminal voltage,
THEN REPLACE MDB.



Checking voltage of input power to Seakeeper. Connections beside input line is seawater pump supply.

Section 1, Step 3 continued

- c. **IF** Seakeeper equipped with factory-installed seawater pump relay, **THEN PERFORM** following checks:

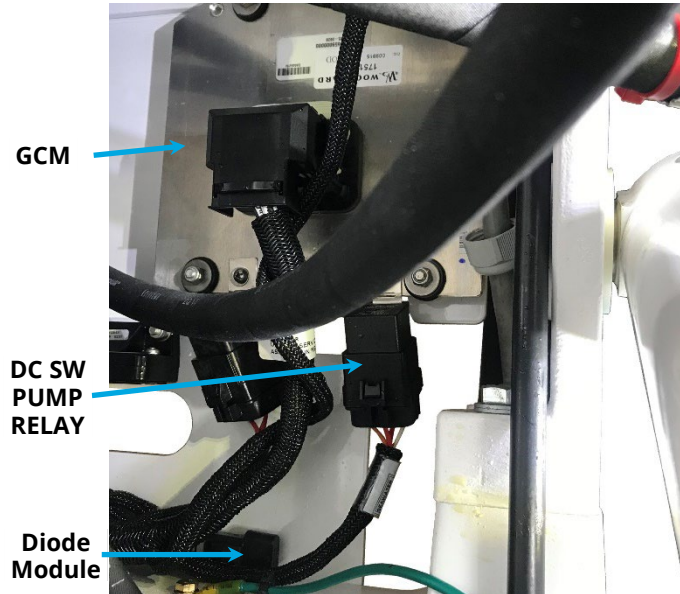

- i. **VERIFY** independent seawater pump supply breaker ON.
- ii. **VERIFY** seawater relay voltage rating is appropriate for model.



Section 1, Step 3.c continued

- iii. **REMOVE** seawater pump relay from harness.
- iv. **TEST** contacts of relay with multimeter in Resistance mode using relay's markings as guide (pin **30** to pins **87A** and **87**):

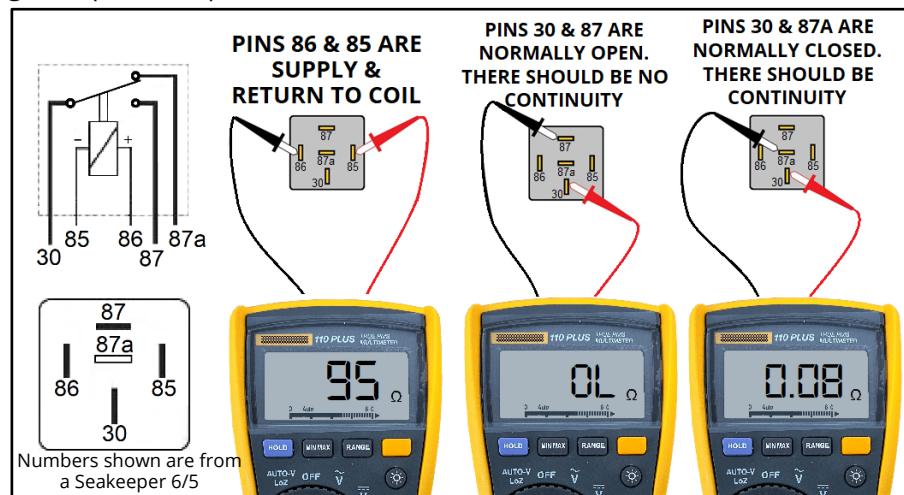

1. With multimeter in Resistance mode, **TEST** relay coil resistance (pin **85** and **86**).
Resistance: _____ ohms
 2. **TEST** for open loop between pins **30** and **87**.
 3. **TEST** for continuity between pins **30** and **87A**.
- v. **IF** relay resistance or continuity tests **UNSATISFACTORY**, **THEN REPLACE** seawater pump relay.
 - vi. **IF** relay coil resistance is **NOT** between 324 to 396 ohms for 24-volt systems (81 – 99 for Seakeeper 6/5) in Step 3.c.iv, **THEN REPLACE** seawater pump relay.
 - vii. **IF** supply breaker and seawater relay checks are satisfactory, **THEN VERIFY** wiring at seawater pump is correctly terminated.
 - viii. **DISCONNECT** seawater output power to seawater pump at DC SW pump.
 - ix. **ACTIVATE** seawater override.

Section 1, Step 3.c continued

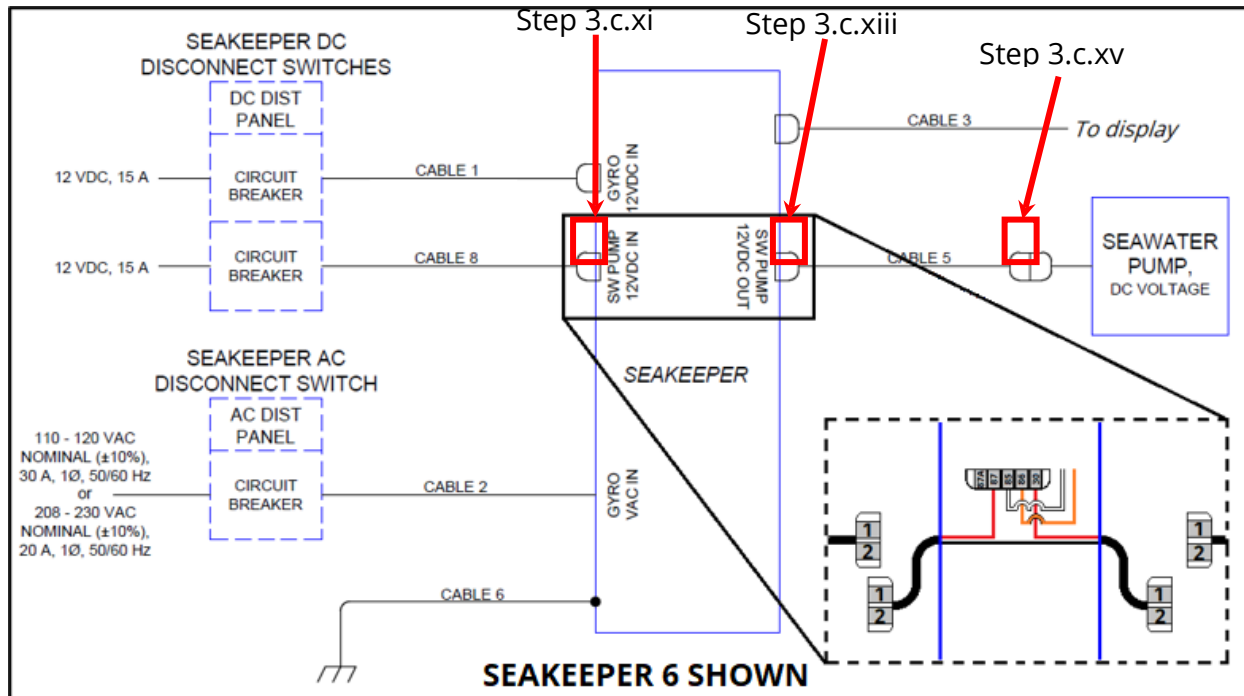

- x. **DISCONNECT** SW PUMP IN cable at Seakeeper wire harness.
- xi. **CONFIRM** DC voltage in SW PUMP IN cable between pins **1** and **2**.
- xii. **DISCONNECT** SW PUMP OUT cable from Seakeeper harness.
- xiii. **CONFIRM** DC voltage at seawater output power harness connector between pins **1** and **2**.
- xiv. **RECONNECT** SW PUMP OUT cable to Seakeeper harness.
- xv. **CONFIRM** DC voltage between pins **1** and **2** of SW PUMP OUT cable at seawater pump.
 - 1. **IF** voltage NOT present at end of SW PUMP OUT cable, but present in step 3.c.xi, **THEN REPLACE** SW PUMP OUT cable.
 - 2. **IF** voltage present, **THEN REPLACE** seawater pump.

Section 1, Step 3.c continued

- xvi. **IF** voltage present in Step 3.c.xi **AND NOT** in step 3.c.xiii, **THEN:**

1. **VERIFY** wires and crimps of harness SW input and output connectors secure.
2. **IF** wire(s) or crimp(s) NOT secure, **THEN REPAIR** affected connector(s).
3. **IF** wires and crimps secure, **THEN REPLACE** discrete seawater switching harness (Seakeeper 18 & 40 do not have a switching harness; entire wire harness will require replacement).

- xvii. **IF** voltage NOT present in Step 3.c.xi, **THEN:**

1. **INSPECT** breaker connections secure.
2. **IF** breaker connections secure, **THEN REPLACE** SW PUMP IN cable.

- xviii. **DEACTIVATE** seawater override.

- xix. **RECONNECT** all connections.

- d. **IF** seawater pump powered from customer-supplied relay per image **AND** seawater pump NOT running,

THEN:

- i. **ENSURE** independent power supply to seawater pump is aligned.
- ii. **PERFORM** Section 1, Steps 3.c.i through 3.c.vi to test power to relay coil.

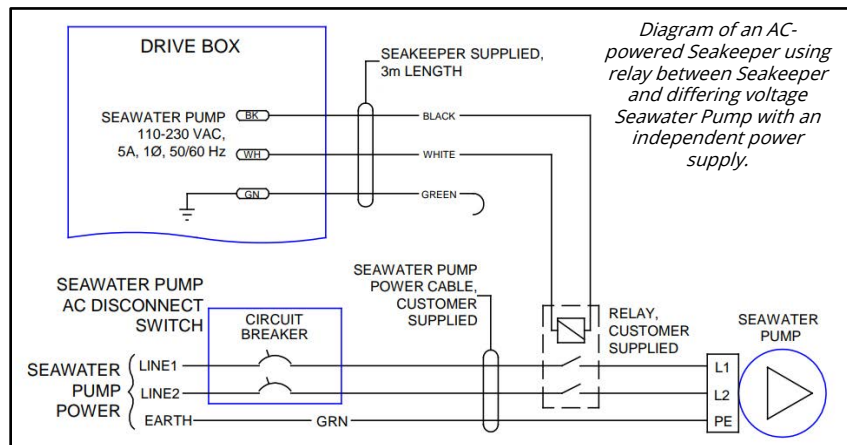

PRODUCT SEAKEEPER SERIES MODELS

Code 6/104/157

Section 1, Step 3.d continued

- iii. **ACTIVATE** seawater override.
 - iv. **CONFIRM** DC voltage at seawater pump.
 - v. **IF** proper voltage NOT present at motor,
 THEN:
 - 1. **TEST** voltage at independent power supply breaker.
 - 2. **IF** voltage at breaker UNSATISFACTORY,
 THEN TROUBLESHOOT vessel electrical supply.
 - 3. **TEST** continuity of power supply from breaker to relay.
 - 4. **TEST** continuity of power supply from relay to seawater pump motor.
 - 5. **IF** continuity in power supply UNSATISFACTORY,
 THEN REPLACE effected power cable.
 - 6. **DETERMINE** relay coil resistance from manufacturer's data.
 - 7. **TEST** relay coil for proper resistance.
 - 8. **IF** coil resistance UNSATISFACTORY,
 THEN REPLACE customer-supplied seawater relay.
 - 9. Using relay's data, **TEST** for continuity across relay contacts.
 - 10. **IF** relay contact continuity UNSATISFACTORY,
 THEN REPLACE customer-supplied relay.
 - vi. **IF** proper voltage found at seawater pump motor,
 THEN REPLACE seawater pump.
4. **IF** MDB cover removed,
 THEN:
- a. **PLACE** cover back on MDB.
 - b. **TORQUE** ten M4 Phillips head screws to **19 in-lbs (2.2 Nm)**.

PRODUCT SEAKEEPER SERIES MODELS

Code 6/104/157

5. With Seawater Override activated, **VERIFY** seawater flow is adequate for applicable model per [ATTACHMENT 1](#). [Flow meter, as shown, is desirable, but a bucket and stopwatch can be used.]



6. **IF** flow below recommended range of [ATTACHMENT 1](#), **THEN PERFORM** following:
- a. **VERIFY**, by nameplate data, pump can deliver required volume at supplied voltage.
 - b. **VERIFY** Seacock valve is fully **OPEN**.
 - c. **IF** Seakeeper 40 and equipped with electric ball valve), **THEN VERIFY** electric ball valve in suction of SW pump is open per the valve position indication on top of operator.
 - i. **IF** ball valve closed when SW pump override activated, **THEN MANUALLY OPEN** electric ball valve as follows:
 1. **LIFT** up on white knob on top of valve operator.
 2. **TURN** white knob in either direction to open valve.
 3. **PUSH** white knob into valve operator.
 - d. **VERIFY** strainer is clear of debris.
 - e. **IF** flow restriction valve installed, **THEN:**
 - i. **VERIFY** flow rate setting to Seakeeper is appropriately set.
 - ii. **IF** dual inlets installed, **THEN VERIFY** flow is correct for other Seakeeper(s).
 1. **BALANCE** flow, as necessary.
 - f. **ENSURE** seawater plumbing is routed on continuous uphill from intake to discharge to minimize air in system per [ATTACHMENT 2](#).

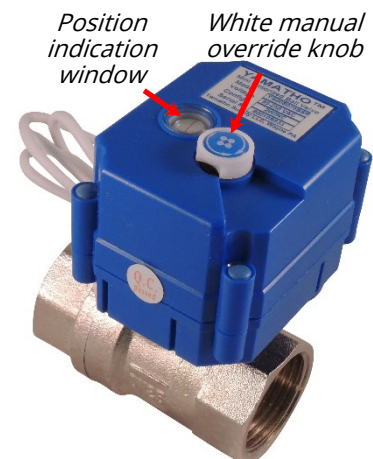

PRODUCT SEAKEEPER SERIES MODELS

Code 6/104/157

7. **IF** seawater pump cavitating or air locked,
THEN ENSURE no leaks in seawater line as follows:
 - a. **INSPECT** piping/hoses/components from hull penetration to seawater pump for indications of air in-leakage.
 - b. **INSPECT** heat exchanger for any signs of external leakage.
 - c. **INSPECT** discharge hose/piping for any signs of leakage.
 - d. **REPAIR** any leakage found.
 - e. **ACTIVATE** seawater override.
 - f. **OPEN** heat exchanger reservoir cap to monitor level.
 - g. **IF** level rising/over-flowing (due to seawater leakage into coolant system),
THEN:
 - i. **REPLACE** heat exchanger.
 - ii. **FLUSH** glycol system with freshwater (5 gal./ 19 L at minimum).
 - iii. **REFILL AND FLUSH** system with glycol per [SWI-107](#).
 - h. **IF** seawater pump still air-locked,
THEN CONSIDER:
 - i. Educating vessel owner of operations that can cause air-locking
 - ii. Moving intake scoop
 - iii. Upgrading to self-priming pump
8. **PRIME** pump (by venting air at hose connections higher than pump) to remove all air.
9. **IF** no issues found in seawater loop,
THEN GO TO [SECTION 3](#).

SECTION 2: DC-POWERED MODELS

- ACTIVATE** seawater override.

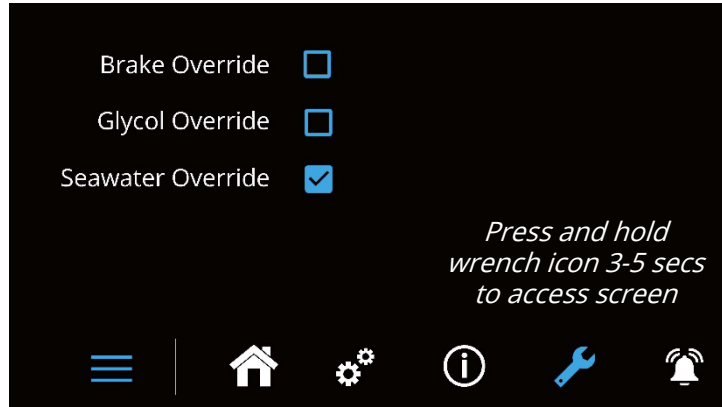

- IF** seawater pump running with override, **THEN PROCEED** to [Section 2, Step 4](#).

- IF** seawater pump NOT running, **THEN PERFORM** following:

- DETERMINE** power alignment of seawater pump.

EXAMPLE: Is it powered from Seakeeper’s wire harness or through a customer-supplied relay.

- Seakeeper 2 & 3 models (before S/Ns 2-204-0400 and 3-204-1425) power seawater pump (or a customer-supplied relay) through wire harness and 3A fuse.
- Seakeeper 2 & 3 models (S/Ns 2-204-0400 and 3-204-1425 and after) use a seawater relay on a wire harness adapter on Seakeeper.

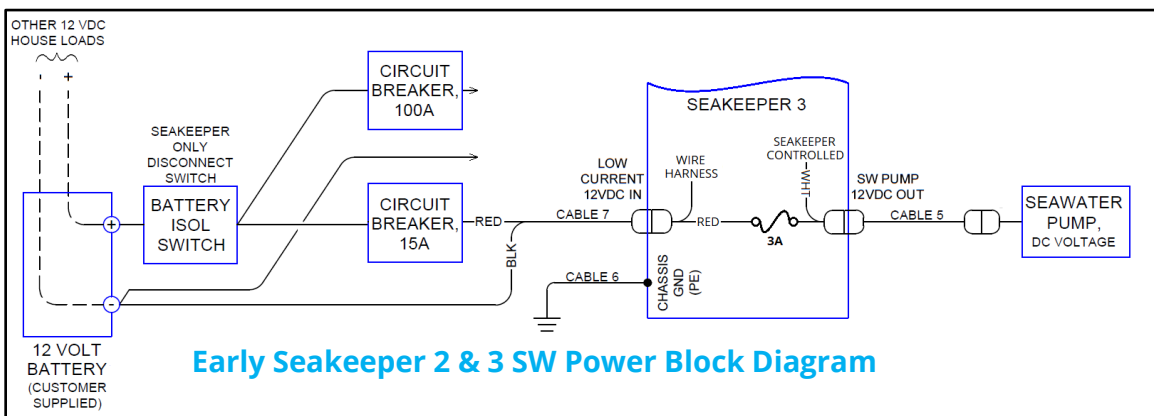

Section 2, Step 3.a continued

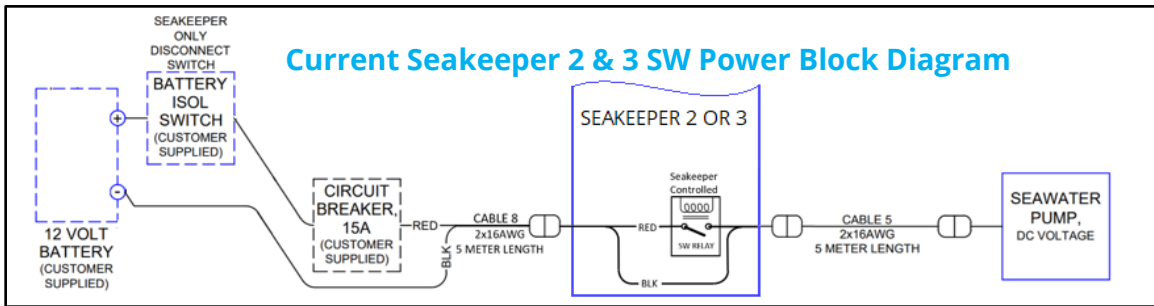

- b. **IF:**
- Seakeeper 2 (S/N 2-204-0400 and after) or
 - Seakeeper 3 (S/N 3-204-1425 and after),

THEN:

- ENSURE** flywheel at zero RPM at display/MFD app.
- TURN OFF** high current DC and seawater pump breakers.
- VERIFY** relay is rated for 12VDC.

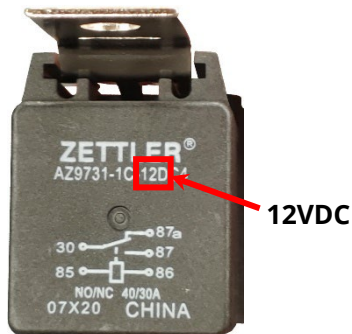

Section 2, Step 3.b continued

- iv. **REMOVE** seawater pump relay from harness.
- v. With multimeter in resistance mode, **TEST** relay coil resistance between pins **86** and **85**. (see diagram next page for details)

Resistance: _____ ohms

- vi. **IF** relay coil resistance is NOT between 81 – 99 ohms, **THEN REPLACE** seawater pump relay.
- vii. **TEST** contacts of relay with multimeter using relay's markings as guide. (See diagram below)

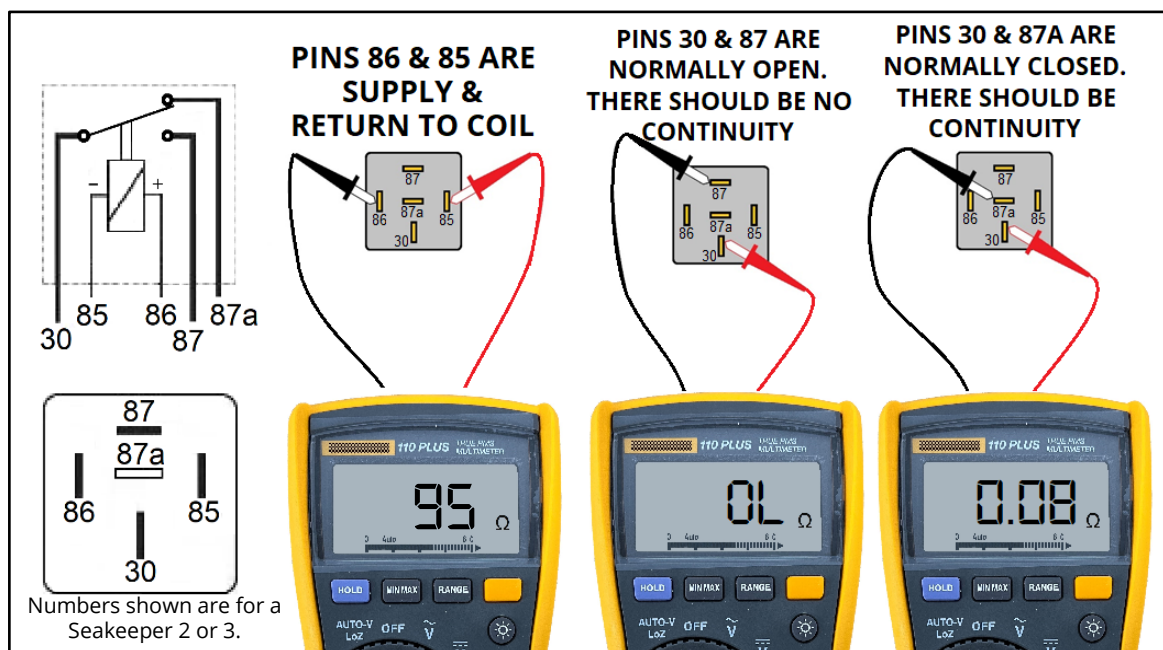

1. **ENSURE** open loop between pins **30** and **87**.
 2. **ENSURE** continuity between pins **30** and **87a**.
- viii. **IF** relay continuity and resistance tests **UNSATISFACTORY**, **THEN REPLACE** seawater pump relay.
 - ix. **TURN ON** independent seawater pump supply breaker.

Section 2, Step 3.b continued

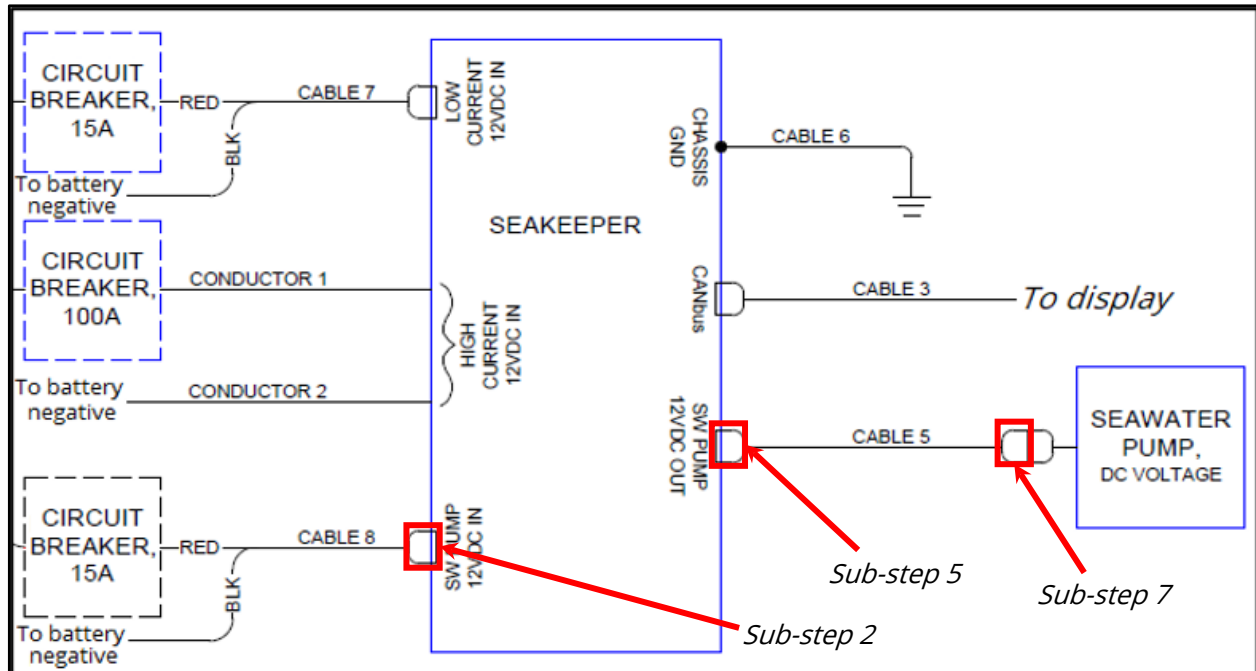
x. **PERFORM** following electrical measurements:

1. **DISCONNECT** SW PUMP IN cable to Seakeeper.
2. **CONFIRM** 12VDC in SW PUMP IN cable between pins **1** and **2**.
3. **DISCONNECT** SW PUMP OUT cable from Seakeeper.
4. **ACTIVATE** seawater override.
5. **CONFIRM** 12VDC at seawater output power harness connector between pins **1** and **2**.
6. **DISCONNECT** SW PUMP OUTPUT cable at seawater pump.
7. **CONFIRM** DC voltage between pins **1** and **2** at seawater pump.
8. **IF** voltage present in 3.b.x.7, **THEN REPLACE** seawater pump.
9. **IF** voltage NOT present in 3.b.x.7 **but** present in step 3.b.x.5, **THEN REPLACE** SW PUMP OUT cable.

Section 2, Step 3.b continued

- xi. **IF** voltage present in step 3.b.x.2 **AND NOT** in step 3.b.x.5,
THEN:
 - 1. **VERIFY** wires and crimps of harness SW input and output connectors secure.
 - 2. **IF** wire(s) or crimp(s) NOT secure,
THEN REPAIR affected connector(s).
 - 3. **IF** wires and crimps secure,
THEN REPLACE discrete seawater harness.

- xii. **IF** voltage NOT present at SW PUMP IN cable to Seakeeper in step 3.b.x.2,
THEN:
 - 1. **INSPECT** breaker connections secure.
 - 2. **IF** breaker connections secure,
THEN REPLACE SW PUMP IN cable.

- xiii. **DEACTIVATE** seawater override.

- xiv. **RECONNECT** all connectors.

SEAKEEPER TROUBLESHOOTING GUIDE - 106



PRODUCT SEAKEEPER SERIES MODELS

Code 6/104/157

Section 2, Step 3.b continued

- xv. **IF** Seakeeper 2 or 3,
THEN VERIFY 3A seawater fuse NOT blown.

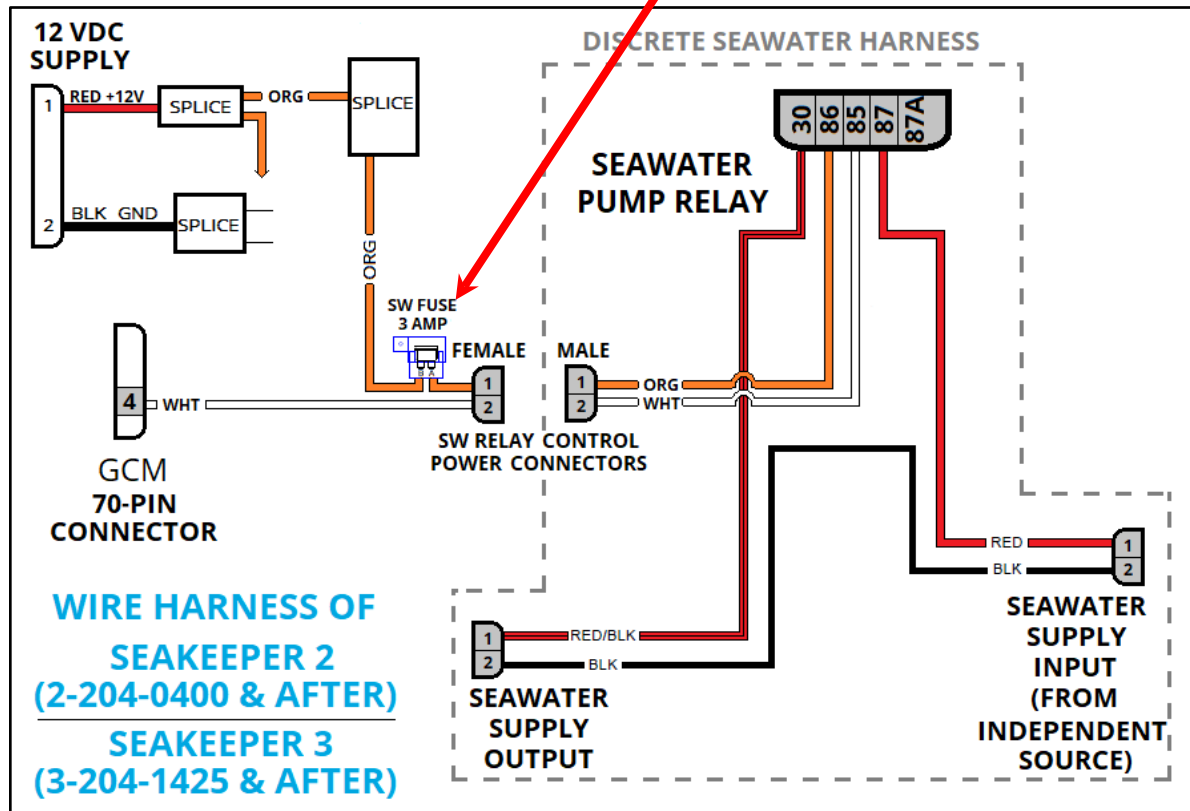
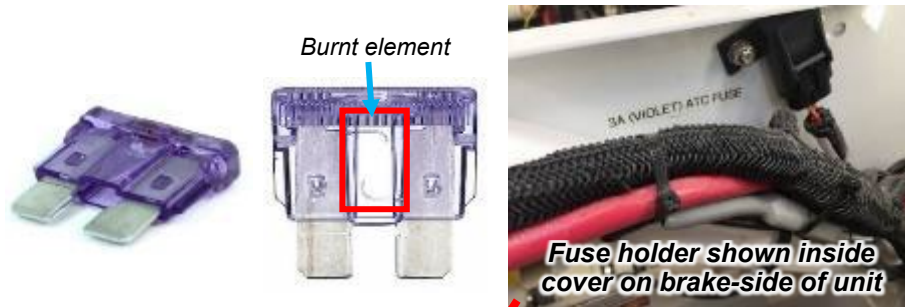

Section 2, Step 3.b continued

xvi. **MEASURE** resistance between following:

1. **ENSURE** resistance 0.3Ω or less between DC Input Deutsch connector Pin **1** and seawater relay control power female connector Pin **1**.

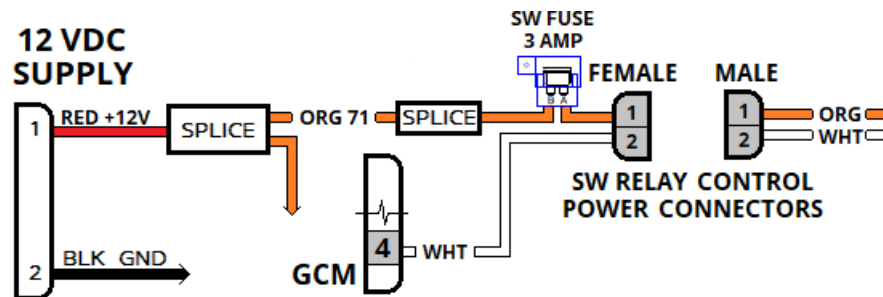

2. **ENSURE** resistance 0.3Ω or less between GCM 70-pin connector Pin **4** and SW Relay control power female connector Pin **2**.
3. **ENSURE** resistance 0.3Ω or less between SW Relay control power male connector Pin **1** and SW Relay connector Pin **86**.
4. **ENSURE** Open Loop (no short) between Pin **1** and Pin **2** of SW Relay control power connector.

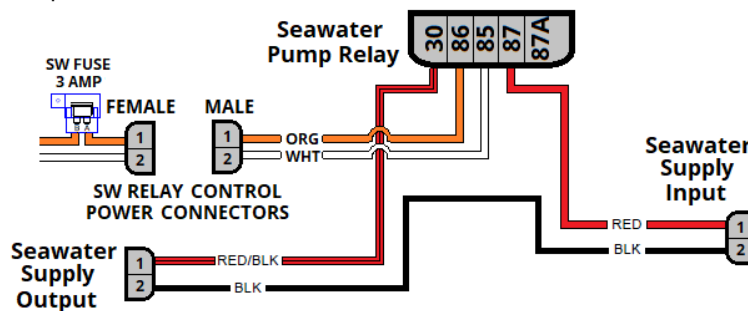

5. SW Relay control power male connector Pin **2** and SW Relay connector Pin **85**.
6. SW Supply Input connector Pin **2** and SW Supply Output connector Pin **2**.
7. SW Supply Input connector Pin **1** and SW Relay connector Pin **87**.
8. SW Supply Output connector Pin **1** and SW Relay connector Pin **30**.

- xvii. **IF** any measurements of Step 3.b.xvi UNSATISFACTORY, **THEN CONTACT** Seakeeper at support@seakeeper.com regarding harness replacement with all data collected.

Section 2, Step 3 continued

- c. **IF** Seakeeper 2 or 3 (before S/Ns 2-204-0400 and 3-204-1425), **THEN PERFORM** following:

- i. **VERIFY** 3A seawater fuse NOT blown.



- 1. **IF** fuse size greater than 3A found, **THEN PROCEED** to Step 4.

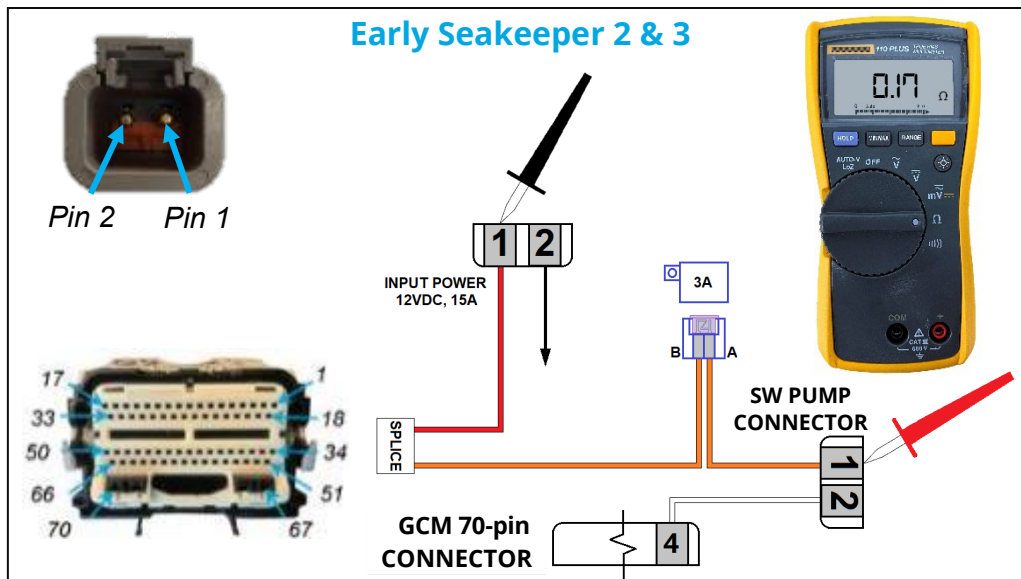

- ii. **DISCONNECT** 12VDC Input connector **AND** GCM 70-pin connector.
- iii. **ENSURE** resistance 0.3Ω or less between following:
 - 1. 12VDC Input connector Pin **1** and SW Pump connector Pin **1**.
 - 2. SW Pump connector Pin **2** and GCM 70-pin connector Pin **4**.
 - 3. SW Pump connector Pin **1** and Pin **2** for short.
- iv. **VERIFY** Open Loop (no short) between Pin **1** and Pin **2** of SW Pump connector.
- v. **IF** any measurement in Step 3.c.iii or 3.c.iv is **UNSATISFACTORY** and fuse not blown, **THEN CONTACT** Seakeeper at support@seakeeper.com regarding harness replacement with all data collected.

Section 2, Step 3 continued

- d. **IF** Seakeeper powers customer-supplied relay for seawater pump power, **THEN TROUBLESHOOT** from seawater pump breaker to SW Pump motor.

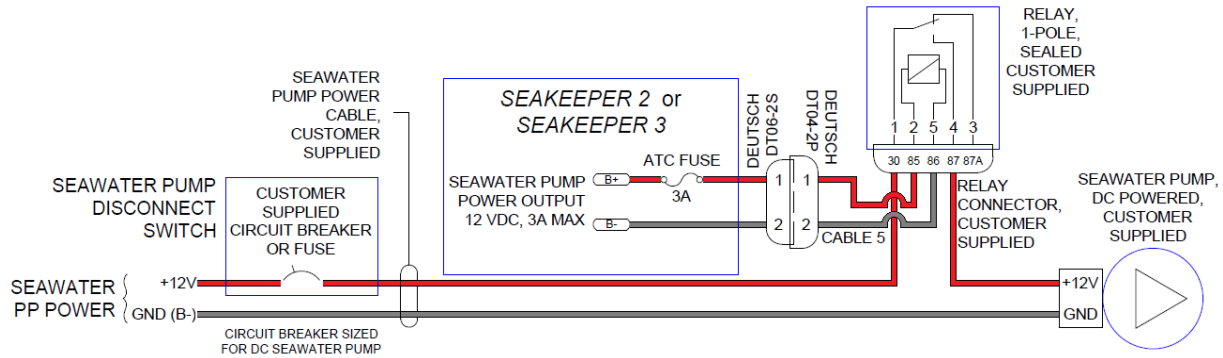

- e. **RECONNECT** GCM and 12VDC Input connections.

- 4. **IF** Seakeeper 2 or 3 with serial number prior to 2-204-0400/3-204-1425 **AND** greater than 3A fuse found **OR** seawater pump runs continuously, **THEN:**

- a. **DISCONNECT** GCM plug, low current 12VDC Input, and DC SW PUMP OUT connector.
- b. **VERIFY** no short (high resistance) between pins **1** and **2** of DC SW PUMP OUT connector.
- c. **VERIFY** no short (high resistance) between Pin **2** of DC SW PUMP OUT and Pin **2** of harness low current DC Input connector.
- d. **CONNECT** GCM connector.

PRODUCT SEAKEEPER SERIES MODELS

Code 6/104/157

5. **IF** seawater pump running, but flow is not within 2 to 6 GPM (7.6 to 22.7 LPM),

THEN VERIFY:

- a. By nameplate data, pump can deliver required volume at supplied voltage.
- b. Seacock valve is fully OPEN.
- c. Strainer is clear of debris
- d. Flow restriction valve to Seakeeper is appropriately set, if installed.
- e. Seawater plumbing is routed on continuous uphill from intake to discharge to minimize air in system per [ATTACHMENT 2](#).



PRODUCT SEAKEEPER SERIES MODELS

Code 6/104/157

6. **IF** Seawater Pump cavitating or air locked,
THEN PERFORM following:
 - a. **IF** vessel lifted routinely,
THEN ENSURE air locking is not occurring from system drainage.
 - b. **IF** vessel equipped with pod drives or GPS anchoring system,
THEN ENSURE air locking/cavitation not occurring from devices during maneuvers.
 - c. **IF** vessel uses common seawater chest,
THEN ENSURE seawater chest free of air.
 - d. **INSPECT** piping/hoses/components from hull penetration to seawater pump for indications of air in-leakage.
 - e. **INSPECT** heat exchanger for any signs of external leakage.
 - f. **INSPECT** discharge hose/piping for any signs of leakage.
 - g. **REPAIR** any leakage found.
 - h. **IF** vessel is in water,
THEN:
 - i. **ACTIVATE** Seawater Override.
 - ii. **OPEN** heat exchanger reservoir cap to monitor level.
 - iii. **IF** level rising/over-flowing,
THEN:
 1. **REPLACE** heat exchanger.
 2. **FLUSH** glycol system with freshwater (5 gal./ 19 L at minimum).
 3. **REFILL AND FLUSH** system with glycol per [SWI-107](#).
 - i. **IF** cavitation or air locking persists without resolution,
THEN CONSIDER:
 - i. Educating vessel owner of operations that can cause air-locking.
 - ii. Relocating intake scoop.
 - iii. Replacing seawater pump with self-priming pump.
7. **RESTORE** power to Seakeeper.
8. **IF** cause for alarm not found,
THEN GO TO [SECTION 3](#).

SECTION 3: GLYCOL LOOP ISSUES

CAUTION:

GLYCOL PUMP DAMAGE MAY OCCUR FROM RUNNING WITHOUT VISIBLE GLYCOL IN RESERVOIR.

1. **ENSURE** proper amount of coolant inside heat exchanger by removal of reservoir filler cap.
 - a. **IF** coolant level is low, **THEN:**
 - i. **CHECK** entire glycol system for leak.
 - ii. **IF** leak is found, **THEN REPAIR** leaking component.
 - iii. **FILL** reservoir with same type glycol in system (typically 50/50 Ethylene Glycol and Distilled Water) per [SWI-107](#).

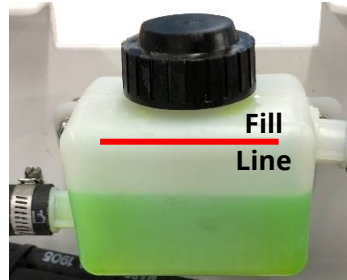
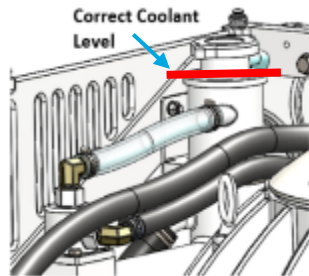

2. **ACTIVATE** glycol override to circulate coolant.

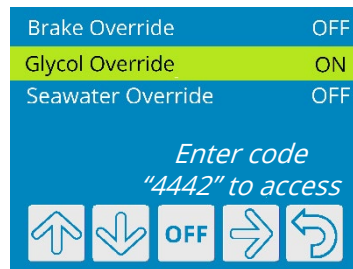
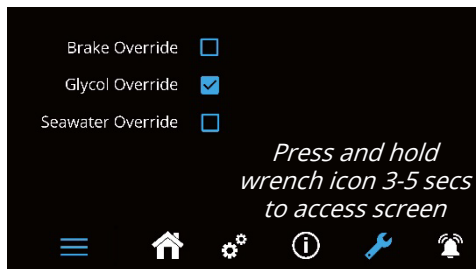

PRODUCT SEAKEEPER SERIES MODELS

Code 6/104/157

3. **REMOVE** reservoir filler cap.
4. **CHECK** for turbulent flow at filler neck.
 - a. **IF** no flow turbulence seen, **THEN PINCH/RESTRICT** bypass hose of enclosure cooling jackets **AND LISTEN** for flow noise.
 - b. **IF** no indication of flow, **THEN PERFORM** following:

- i. With glycol override still activated, **CONFIRM** voltage between pins **1** and **2** of harness connector to glycol pump by back-probing Deutsch connector.



- ii. **IF** voltage NOT within 0.3 volts of DC INPUT voltage, **THEN:**
 1. **DEACTIVATE** glycol override.
 2. **DISCONNECT** GCM 70-pin connector.
 3. **VERIFY** 0.3Ω or less between pin **2** of harness glycol pump connector and GCM pin **15** (pin **4** for #2 glycol pump of Seakeeper 35 and 40).

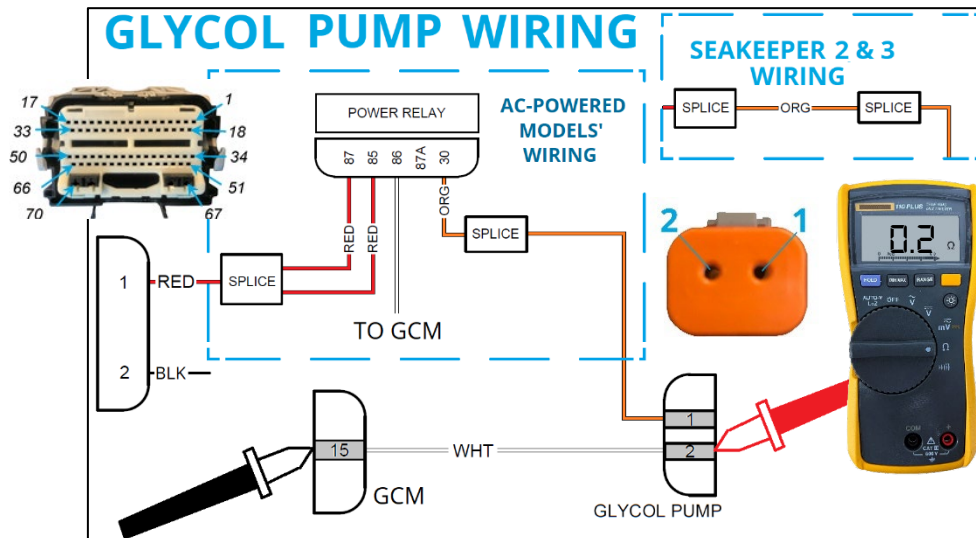

4. **VERIFY** 0.3Ω or less between harness glycol pump connector pin **1** and harness power relay pin **30** (AC-powered models) **OR** pin **1** of low current DC input harness connector (Seakeeper 2 & 3 models).

Section 3, Step 4.b continued

NOTE:

A faulty glycol pump or pump motor can burn out internal GCM glycol pump circuit. Issue may remain if just replacing glycol pump.

- iii. **IF** voltage in Step 4.b.i and resistance checks in Step 4.b.ii.3 & 4 are **SATISFACTORY AND** no Code 8/9,
THEN:
 - 1. **PERFORM** bench test of glycol pump (with independent power source with DC voltage matching Seakeeper)
 - 2. **IF** pump does not operate,
THEN REPLACE glycol pump.
 - 3. **IF** pump operates on bench but not in Seakeeper,
THEN REPLACE GCM **AND** glycol pump.
- iv. **RECONNECT** all harness connections opened.
- v. **IF** glycol flow NOT re-established,
THEN CHECK for blockage in coolant paths as follows:
 - 1. **OBTAIN** bucket/container to catch glycol from system.
 - 2. **REMOVE** coolant hose at each component in cooling loop and direct to bucket.
 - 3. **ACTIVATE** glycol override.
 - 4. **FLUSH** glycol loop with freshwater hose.
 - 5. **IF** blockage suspected in water jackets of enclosure,
THEN:
 - 6. **REMOVE** enclosure water jackets and clean coolant channels.
 - 7. **REINSTALL** enclosure water jackets (torque specifications available in [Torque Specifications](#)).
 - 8. **PERFORM** [SWI-107](#) Glycol Service procedure to restore glycol.

SEAKEEPER TROUBLESHOOTING GUIDE - 106



PRODUCT SEAKEEPER SERIES MODELS

Code 6/104/157

5. **IF** alarm persists,
THEN:
 - a. **COLLECT** all data taken from testing.
 - b. **SUBMIT** data to Seakeeper Product Support Team at support@seakeeper.com for review.

******* END *******

SEAKEEPER TROUBLESHOOTING GUIDE - 106

PRODUCT SEAKEEPER SERIES MODELS

Code 6/104/157

ATTACHMENT 1 - Seawater Requirements per Model

Page 1 of 1

MODEL (S/N RANGE)	FLOW RANGE GPM (LPM)	SEAWATER PUMP POWER
Seakeeper 2 (2-0001 to 2-204-0399)	2 – 6 (7.6 – 22.7)	12VDC, 3A
Seakeeper 2 (2-204-0400 to current)	2 – 4 (7.6 – 15.1)	12VDC, 15A
Seakeeper 3 (3-0001 to 3-204-1424)	2 – 6 (7.6 – 22.7)	12VDC, 3A
Seakeeper 3 (3-204-1425 to current)	2 – 4 (7.6 – 15.1)	12VDC, 15A
Seakeeper 5/3DC (EM) (ALL S/Ns)	4 – 8	110/220VAC, 5A
Seakeeper 6/5 (6/5-201-0001 to 6/5-211-2770)	(15.1 – 30.3)	110/220 VAC. 5A
Seakeeper 6/5 (6/5-211-2271 to current)	2.5 – 8 (9.5 – 30.3)	12VDC, 15A
Seakeeper 9/7HD (9-0001 to 9-212-3387)	4 – 8 (15.1 – 30.3)	220VAC, 5A
Seakeeper 9/7HD (9-212-3388 to current)		24VDC, 10A
Seakeeper 16/12HD (EM) (16/12HD-0001 to 16/12HD-193-0912)		220VAC, 5A
Seakeeper 16/12HD & 18 (16/12HD-194-0001 to current) (18-194-0001 to current)		24VDC, 10A
Seakeeper 26/20HD (ALL S/Ns)		220VAC, 5A
Seakeeper 35/30HD (ALL S/Ns)		
Seakeeper 40 (ALL)	13 – 15 (49.2 – 56.8)	24VDC, 20A

ATTACHMENT 2 - Typical Seawater Plumbing

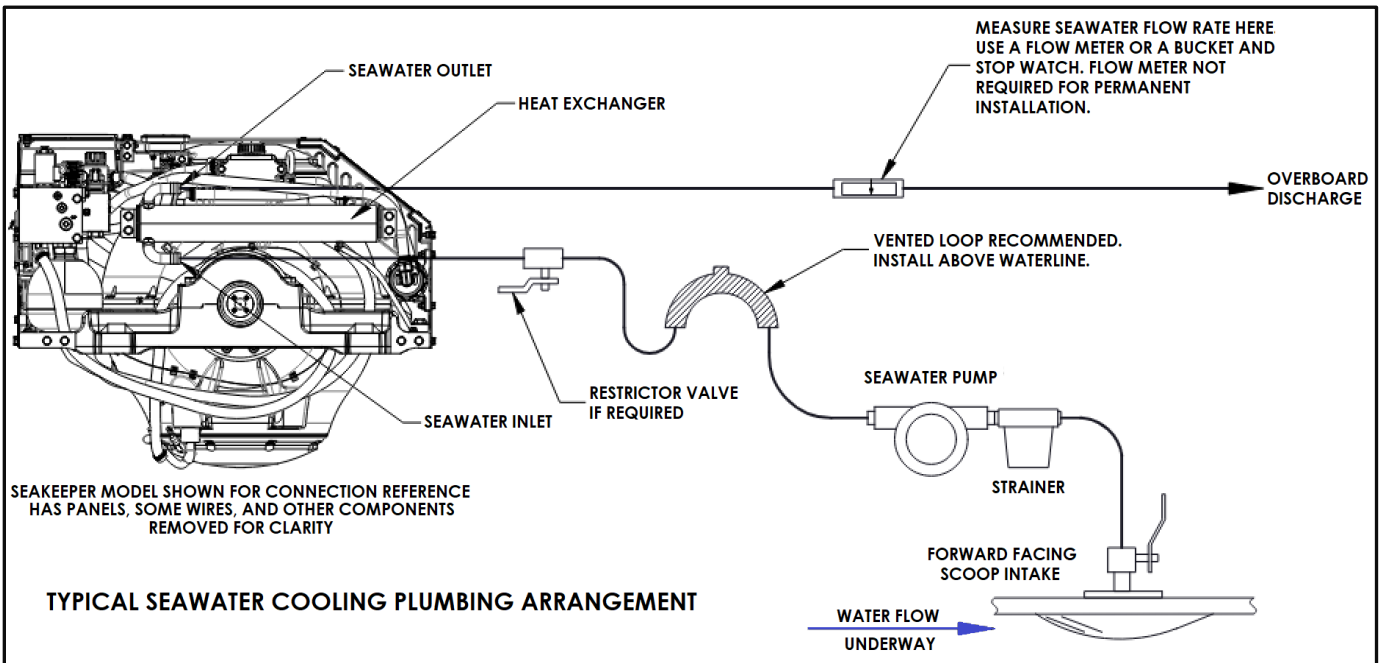

ATTACHMENT 3 - Seakeeper 2 & 3 Customer-Supplied Relay Schematic

This attachment is exclusive to early model Seakeeper 2 and 3 with only 3A fuses and NO factory-installed seawater pump relay.

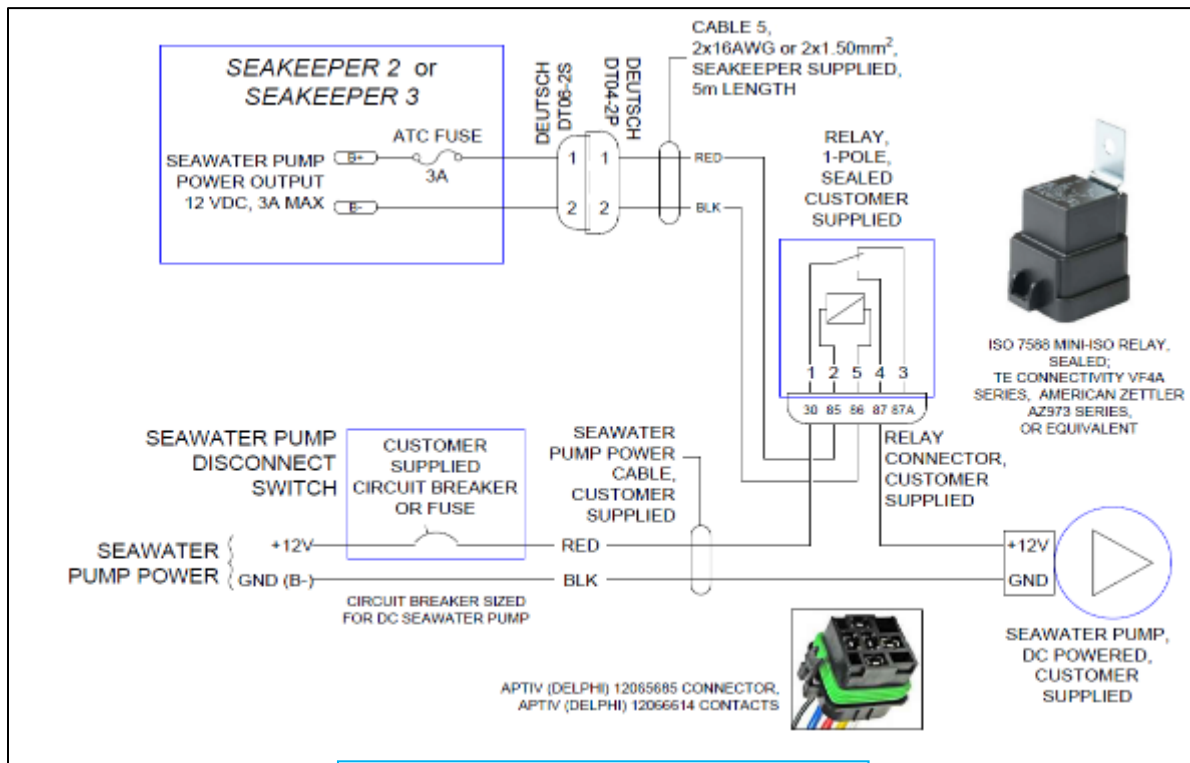

Diagram of a Seakeeper 2 or 3 using a relay between the Seakeeper and the Seawater Pump and an independent power source.

PRODUCT SEAKEEPER SERIES MODELS

**CODE 8/9**

To troubleshoot and repair a COOLANT PUMP 1 FAULT alarm (Code 8) or COOLANT PUMP 2 FAULT alarm (Code 9).

BACKGROUND

The Coolant Pump 1 (and 2, for Seakeeper 35/30HD/40 models only) Fault alarm is produced when the glycol pump current draw is less than 0.25 A, indicating a bad connection, a faulty pump motor or a lack of coolant. Subsequently, the alarm will clear once the amperage rises above 0.25 A. The alarm will remove power from the flywheel motor and lock the Seakeeper.

In factory testing, it was determined that a low DC voltage may trigger a Code 8 in addition to Code 41 (DC Input Voltage Low). If Code 8 is accompanied by Code 41, troubleshoot Code 41 first.

If the failed coolant pump is a yellow legacy glycol pump, it should be replaced with a current-style glycol pump. On the Seakeeper Parts List, there is a glycol pump retrofit kit for each model that had the legacy glycol pump.

*Legacy glycol pump**Current glycol pump***REFERENCES**

Applicable Seakeeper Service Drawings on [Dealer Access](#)

[SWI-107 - Seakeeper Glycol Service work instruction](#)

PRECAUTIONS

See [PRECAUTIONS](#) of Introduction section.

PROCEDURE**WARNING:**

PERSONNEL PINCH HAZARD EXISTS. Seakeeper may be started remotely.

1. **PERFORM** following:
 - a. **TURN OFF** AC or high current DC breaker to Seakeeper.
 - b. **ENSURE** flywheel at zero RPM at display/MFD app.
2. **INSPECT** all electrical connections are secure as follows:
 - a. **VERIFY** glycol pump's connection is secure.
 - b. **ENSURE** GCM 70-pin connector is secure.
3. **CHECK** that glycol level is near maximum fill level.
 - a. **IF** glycol level is low,
THEN FILL reservoir to max fill level.

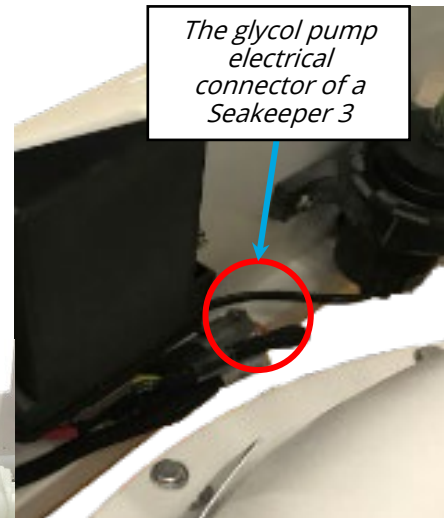
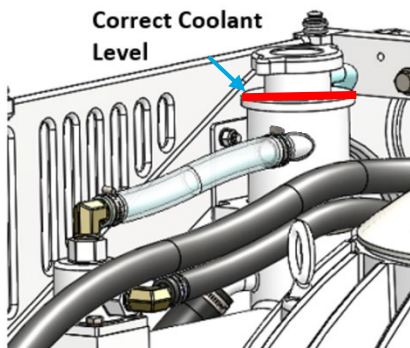

*The glycol pump
electrical
connector of a
Seakeeper 3*

- b. **CYCLE** glycol override off for a few seconds then on again, several times, to purge air from system.

Step 3 continued

- c. **ACTIVATE** glycol override.
- d. **ACTIVATE** brake override.

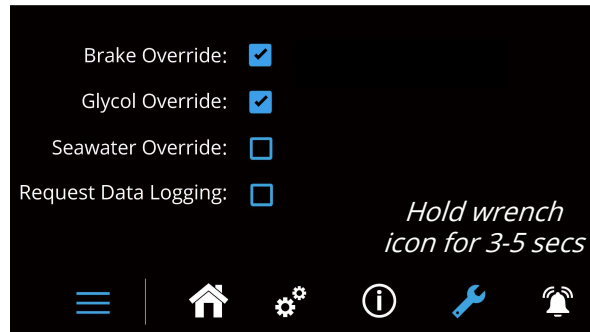
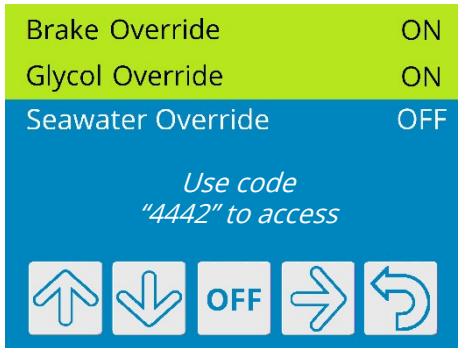

- e. **MANUALLY PRECESS** enclosure, end stop to end stop, several times, to purge all air while glycol pump running.

- 4. **VERIFY** glycol pump is running by touch or noise.
- 5. **IF** glycol pump is not running, **THEN PERFORM** following:



Glycol flow may be seen through fill cap

- a. **DISCONNECT** DC INPUT connector.
- b. **MEASURE** supply DC voltage at DC INPUT.

_____ VDC

- c. **RECONNECT** DC INPUT connector.
- d. **ACTIVATE** glycol override.
- e. With multimeter and back-probes, **VERIFY** DC voltage at glycol pump connector within 0.3 volts of DC INPUT voltage.

_____ VDC

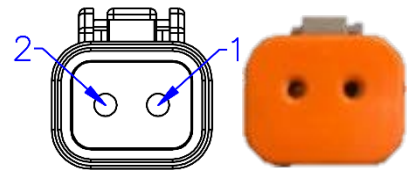

Image of technician back probing glycol pump connector for voltage

Step 5 continued

- f. **IF** no (or low) voltage present, **THEN PERFORM** following tests:
 - i. At DC INPUT, **VERIFY** voltage read in step 5.b for model. (For 12VDC models, voltage should be 11.0-14.0VDC. If 24VDC model, voltage should be 22.0-28.0VDC.)

- ii. **IF** input DC voltage NOT SATISFACTORY, **THEN TROUBLESHOOT** vessel electrical system.



- iii. **IF** DC model, **THEN TEST** for 0.3Ω or less between pin 1 of glycol connector and low DC Input Power positive pin 1 (Red Wire).

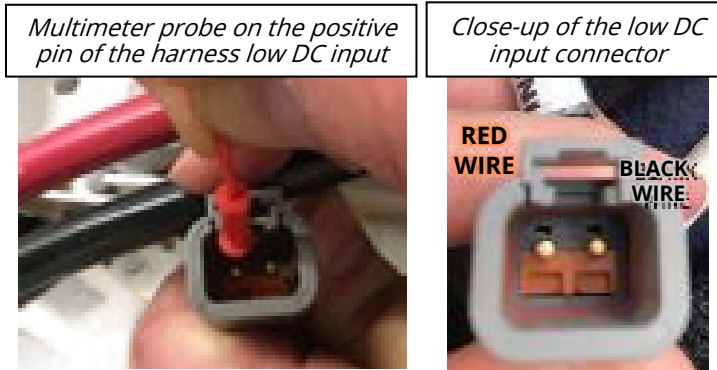

- iv. **IF** AC model, **THEN TEST** for 0.3Ω or less between pin 30 of Power Relay and pin 1 of glycol pump harness connector.

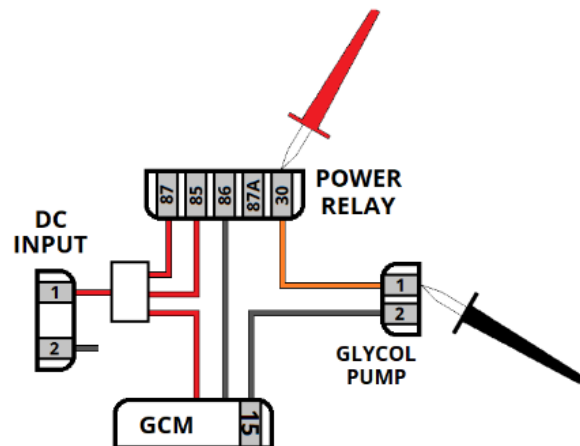
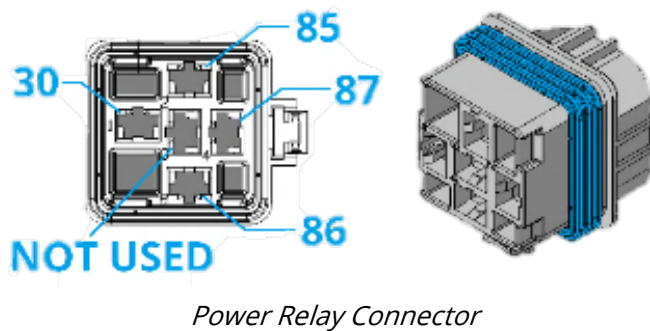

PRODUCT SEAKEEPER SERIES MODELS

Code 8/9

Step 5.f continued

- v. **TEST** for 0.3Ω or less between pin **2** and corresponding GCM pin shown above in [ATTACHMENT 1](#) (pin **15** or **4**).
- vi. **ENSURE** Open Loop exists between pins **1** and **2** of glycol pump connector (no short).
- vii. **IF** there was high resistance in steps 5.f.iii through 5.f.v, **THEN:**
 1. **INSPECT** associated connectors for loose wires or crimps.
 2. **REPAIR** loose wires or crimps if found.
 3. **RETEST** harness for resistances.
 4. **IF** resistances remain greater than 0.3Ω , **THEN REPLACE** wire harness.
- viii. **IF** step 5.f.vi shows a short between pin 1 and 2, **THEN REPLACE** wire harness.
- ix. **RECHECK** for voltage at Glycol Pump.
- x. **IF** no voltage at Glycol Pump after wire harness repair/replacement, **THEN REPLACE** GCM.
- xi. **IF** all checks of step 5 are satisfactory, **THEN REPLACE** glycol pump.



Testing continuity between pin 2 and GCM pin 4 (for Seakeeper 5, 6, or pump 2 on a Seakeeper 35/30HD/40)

SEAKEEPER TROUBLESHOOTING GUIDE - 106



PRODUCT SEAKEEPER SERIES MODELS

Code 8/9

6. **IF** Glycol Pump replaced,
THEN FILL cooling system with glycol mixture per [SWI-107](#).
7. **DEACTIVATE** all overrides.
8. **VERIFY** all alarms clear.
9. **IF** alarm persists,
THEN CONTACT Seakeeper Product Support Team at support@seakeeper.com with all test results collected from procedure and any photos.

******* END *******

ATTACHMENT 1 - GLYCOL TO GCM PINOUT

TABLE 1: GLYCOL TO GCM PINOUT FOR MODELS			
Model	Pin 1	Pin 2	Pump P/N
Seakeeper 2/3	+12VDC	GCM Pin 15	40501
Seakeeper 5/3DC (EM), 5/6		GCM Pin 4	40434
Seakeeper 9(7HD), 18/16(12HD), 26(20HD)	+24VDC	GCM Pin 15	40435
Seakeeper 35/30HD and 40 Pump 1		GCM Pin 15	
Seakeeper 35/30HD and 40 Pump 2		GCM Pin 4	



CODE 15

To troubleshoot and repair a SW PUMP OVERCURRENT Alarm (Code 15).

BACKGROUND

This code is activated by the Seakeeper 2 and 3 models (only) when the seawater pump exceeds 5A current draw. This is an alarm; hence, it secures power to the flywheel motor to spool it down and simultaneously locks the Seakeeper to prevent precession. For the alarm to clear, the seawater pump current must drop below 5A.

The DC-powered models have a 3A ATC fuse in the power supply to the seawater pump. This fuse will open on instantaneous downstream current exceeding 3 amps. Troubleshooting will address a blown fuse and investigate the cause of the overcurrent condition.

On Seakeeper 3-203-1425 or 2-203-0400, and after, the 3-amp fuse lies in the coil power of an internal seawater pump power relay. These models are equipped with a DC seawater pump switching harness containing the relay. Code 15 is still enabled on the late models and should be addressed per this troubleshooting procedure.

In some earlier Seakeeper 2 or 3 installations, there may be a customer-supplied relay in the circuit between the Seakeeper supply and the seawater pump. The relay would operate contacts that close to supply power to the pump, or the relay may simply run a solenoid valve on a seawater header (See diagram below).

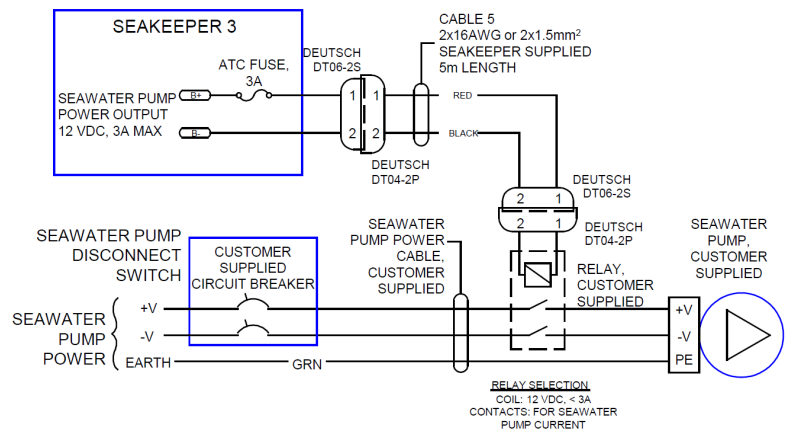

RECOMMENDED WIRING FOR SEAWATER PUMPS NOT 12 VDC OR NOT 3A MAX

REFERENCES

[SB-90647 - Seawater Pump Backwards Compatibility](#)

PRECAUTIONS

See [PRECAUTIONS](#) of Introduction Section.

PROCEDURE

1. **IF** Seakeeper 2 (2-203-0399 or earlier) or Seakeeper 3 (3-203-1424 or earlier), **THEN INSPECT** seawater pump motor label to ensure it meets 12VDC 3-amp (maximum) requirement.
 - a. **IF** not correctly sized for Seakeeper **AND** no seawater relay installed, **THEN REPLACE** seawater pump with adequately sized pump.
2. **PERFORM** following:
 - a. **DEENERGIZE** high current DC power to Seakeeper.
 - b. **ENSURE** flywheel at zero RPM from display/MFD app.
 - c. **INSPECT** fuse of Seakeeper 2/3 located under top front cover on brake side of unit.

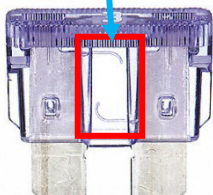
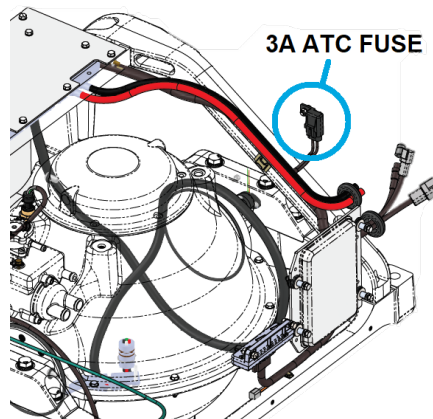
*Burnt element**Example of a blown ATC fuse*

3. **IF** fuse found blown, **THEN:**
 - a. **REPLACE** fuse.
 - b. **PERFORM** following to find cause of overcurrent:
 - i. **DISCONNECT** DC INPUT connector.
 - ii. **DISCONNECT** seawater power supply cable from seawater pump or relay.
 - iii. **DISCONNECT** 70-pin GCM connector.
 - iv. **DISCONNECT** SW PUMP OUT cable (5 m cable).

Step 3 continued

- c. With multimeter, **CHECK** for short between “B” socket (HOT +12VDC orange wire) of fuse holder and pin 2 (Black Ground Wire) of DC INPUT.

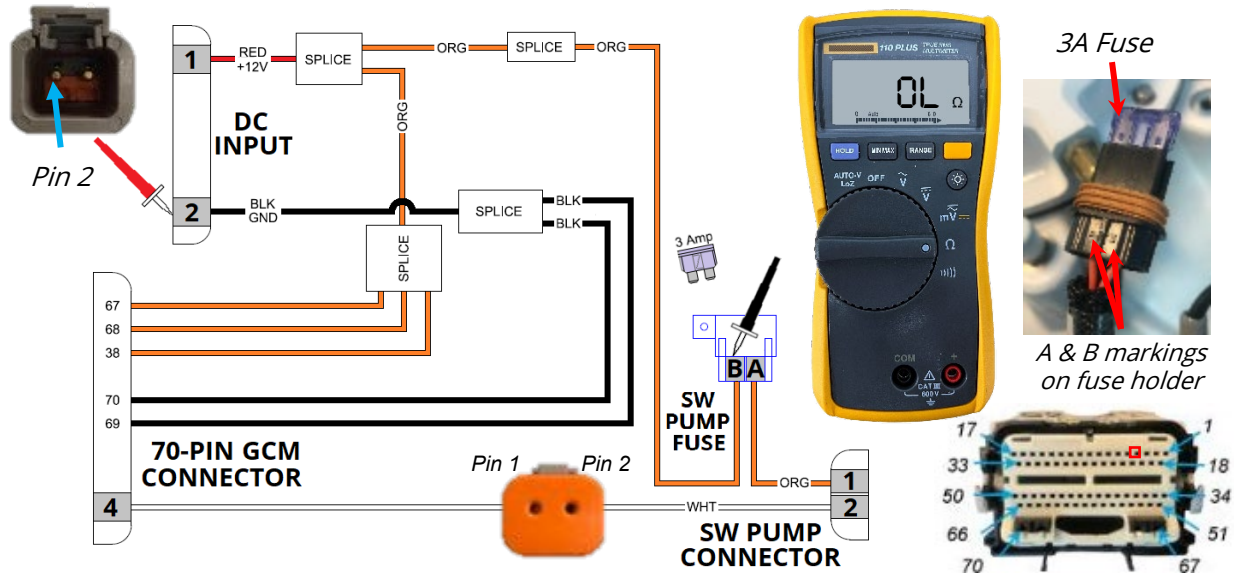

- d. **TEST** for short between “B” socket of fuse holder and pin 4 of 70-pin GCM Connector.
- e. **TEST** for short within harness from “B” socket of fuse holder to socket 1 AND 2 of “SW PUMP” connector.
- f. On “Seawater Pump” connector of harness, **TEST** for short between pin 1 (Orange hot wire) and pin 2 (ground wire to GCM).
- g. **IF** any test in Step 3.c thru f showed a short, **THEN REPLACE** wire harness.

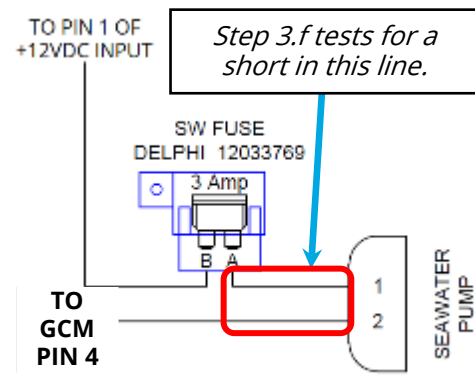

Step 3 continued

- h. **IF** Seakeeper 2 (2-203-0399 or earlier) or Seakeeper 3 (3-203-1424 or earlier), **THEN:**

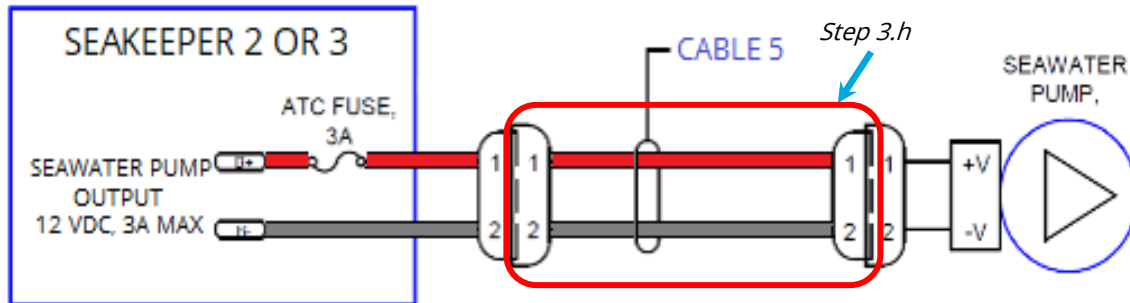

- i. **DISCONNECT** SW PUMP cable from seawater pump or customer relay.
- ii. In male connector of SW PUMP OUT cable connecting to harness, **TEST** for short between pin **1** and pin **2**.
- iii. **IF** short is found in SW PUMP OUT cable, **THEN REPLACE** cable from Seakeeper to pump or relay.
- iv. **IF** all checks of Step 3.c through 3.h.ii were satisfactory, **THEN REPLACE** seawater pump/relay.

Step 3 continued

- i. **IF** Seakeeper 2 (2-203-0400 or later) or Seakeeper 3 (3-203-1425 or later), **THEN:**

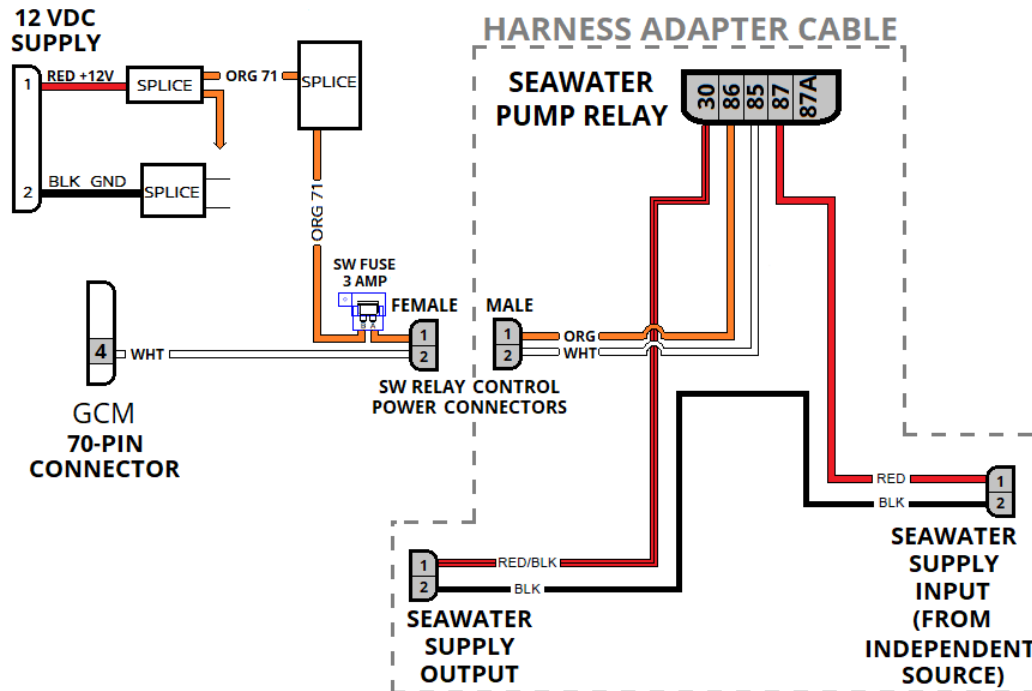

- v. **DISCONNECT** seawater switching harness from wire harness.
- vi. **DISCONNECT** seawater relay from switching harness.
- vii. **VERIFY** less than 0.3Ω between switching harness connector **Pin 1** and relay connector **Pin 86**.
- viii. **VERIFY** less than 0.3 Ω between switching harness connector **Pin 2** and relay connector **Pin 85**.
- ix. **IF** high resistance or no continuity in steps 3.i.iii or 3.i.iv, **THEN REPLACE** seawater switching harness.

NOTE:

At this point, it is assumed that cause for overcurrent condition lies within pump/relay.

4. **REMAKE** all connections of Seakeeper and seawater pump or customer relay.

CAUTION:

PUMP DAMAGE MAY OCCUR IF RUN WITH NO WATER IN CASING.

5. **ALIGN** all power to Seakeeper.
6. **ACTIVATE** seawater override.

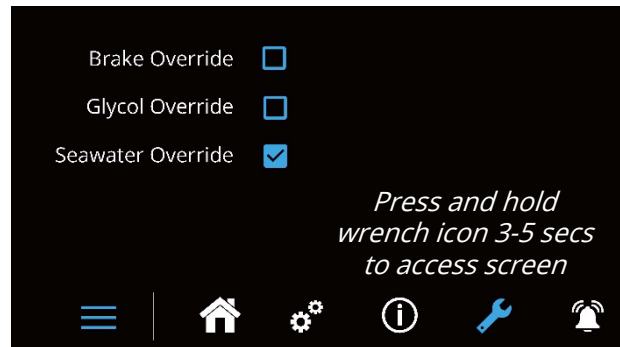
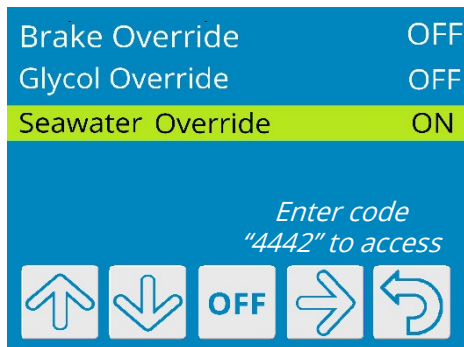

- a. **IF** boat is not in water,
THEN MOMENTARILY BUMP seawater pump electrically (5-10 sec) with override to ensure it will rotate while stationing a local observer at seawater pump if necessary.
7. **CHECK** all alarms clear.
8. **IF** alarm persists,
THEN CONTACT Seakeeper Product Support Team at support@seakeeper.com with results from all testing and any photos.

******* END *******

PRODUCT SEAKEEPER SERIES MODELS

CODE 16

To troubleshoot and repair the DISCRETE SEAWATER PUMP alarm (Code 16).

BACKGROUND

Newer Seakeeper models are equipped with seawater pump power relays that provide seawater pump motor power via a second source of DC power (typically 24VDC but can be 12VDC). The listed models have Code 16 enabled.

Seakeeper 2:	2-203-0400 through current
Seakeeper 3:	3-203-1425 through current
Seakeeper 6/5:	6/5-211-2771 through current
Seakeeper 9:	9-212-3388 through current
Seakeeper 16:	16-194-0001 through current
Seakeeper 18:	18-194-0001 through current
Seakeeper 40:	ALL

Visual characteristics of these models include rectified brake manifolds with only one hydraulic accumulator and heat exchangers with no thermostat housing.

The glycol pumps for these units run if the flywheel motor is energized. The seawater pump is powered on and off through the seawater pump power relay, as needed, based on the MDB internal temperature and operating conditions. The MDB temperature set point for seawater pump start varies between models (see Code 6 [Background](#) for set points).

Troubleshooting will concentrate on the relay and the coil circuitry. In addition to the relay, the models mentioned above have a diode module that can create conditions for an alarm if a failure occurs; troubleshooting will also address this module.

If other cooling system related alarms are active (i.e., [Code 6, "DRIVE TEMPERATURE HIGH"](#) or [Code 73/74, "UPPER/LOWER BEARING TEMPERATURE HIGH"](#)), address this alarm first to clear the other cooling-related alarms possibly..

PRECAUTIONS

See [PRECAUTIONS](#) of Introduction Section.

PROCEDURE

1. **PERFORM** following:
 - a. **TURN OFF** AC or high current DC breaker to Seakeeper.
 - b. **ENSURE** flywheel at zero RPM at display or MFD app.
2. **CHECK** all electrical connections secure on seawater pump power relay.

NOTE:

Diode module is located on wire harness below seawater pump power relay.

3. **CHECK** diode module securely attached to wire harness. **[N/A for DC models]**

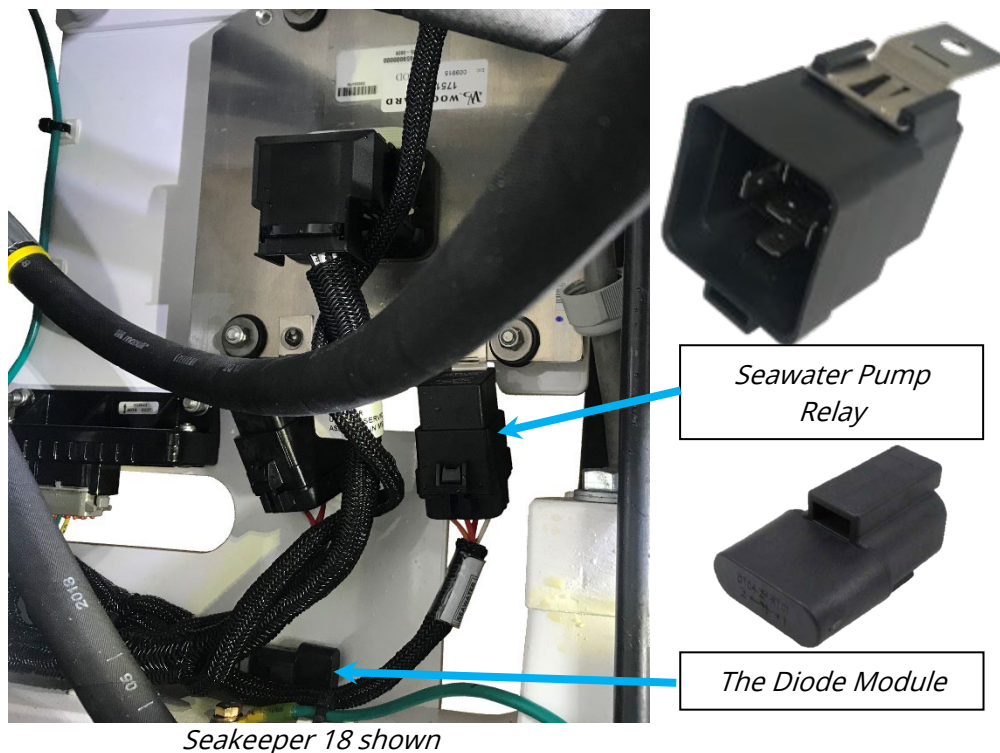

4. **VERIFY** Seawater pump power as follows:
 - a. **VERIFY** DC breaker for seawater pump is ON.
 - b. **ACTIVATE** seawater pump override at display/MFD app.

Step 4 continued

- c. **TEST** for 12VDC (Seakeeper 2 through 6) or 24VDC at seawater pump power line from breaker by back probing connection.
- d. **TEST** for 12VDC (Seakeeper 2 through 6) or 24VDC at Seakeeper pump output line by back probing connection.
- e. **IF** voltage is 10VDC or less for 12VDC systems or 18VDC or less for 24VDC systems, **THEN TROUBLESHOOT** vessel electrical system. [**NOTE:** If seawater pump is aligned to different voltage source, verify that source voltage is satisfactory.]
- f. **DEACTIVATE** seawater pump override.

**WARNING:**

PERSONNEL SHOCK HAZARD EXISTS when working on energized circuits. Seakeeper may be started remotely.

5. **TEST** seawater pump power relay as follows:

- a. **TURN OFF** DC control power supply breaker.
- b. **TURN OFF** DC seawater pump supply breaker.
- c. **VERIFY** nameplate voltage of seawater pump power relay is 12VDC (Seakeeper 2 through 6) or 24VDC (Seakeeper 9 through 40) rating (as shown in photo).
- d. **IF** data marked on relay does NOT state *12DC* (Seakeeper 2 through 6) or *24DC* (Seakeeper 9 through 18 and 40), **THEN REPLACE** seawater pump relay.



Step 5 continued

NOTE:

Removing relay from GCM may allow better access to each pin of relay.

- e. **UNPLUG** wire harness from seawater pump power relay.
- f. With a multimeter, **CONFIRM** 0.3Ω or less between pin **30** and pin **87A** on relay (as shown in figure).

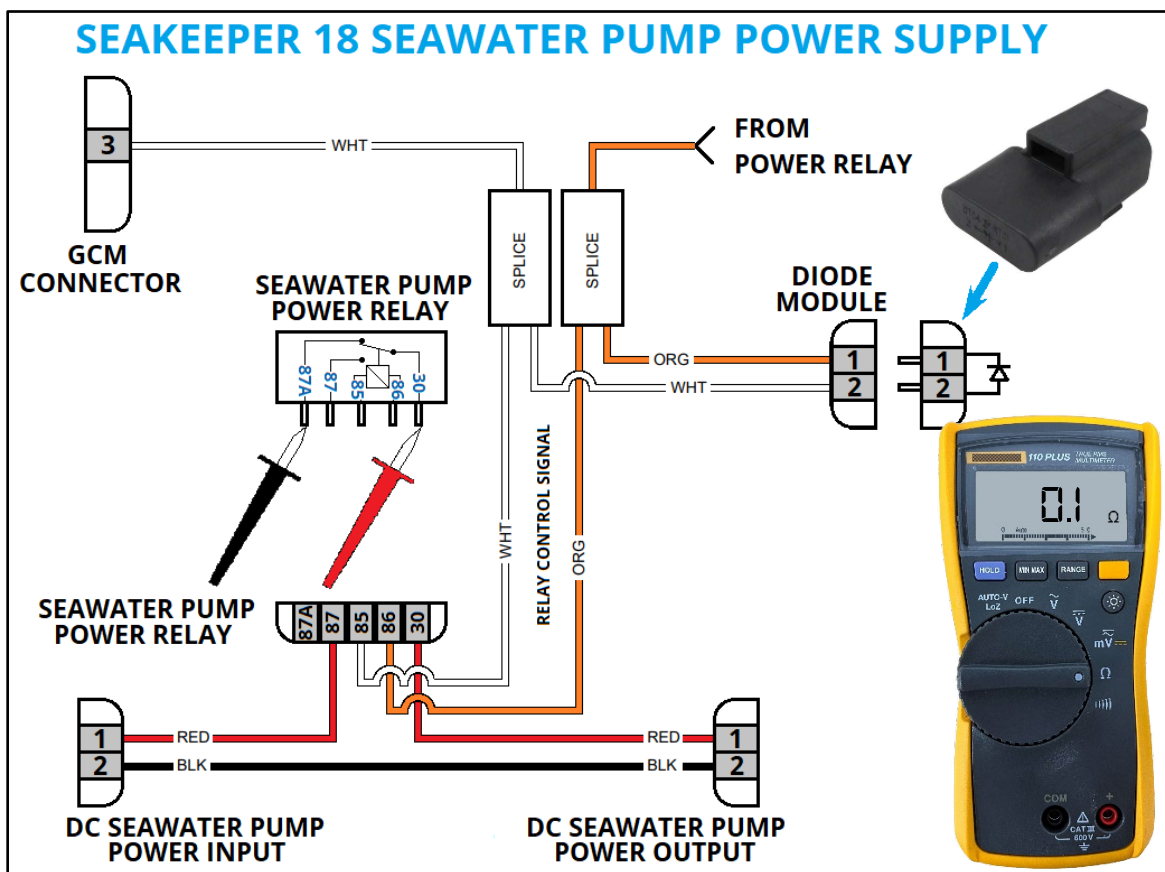

- g. **CHECK** for resistance of 315 to 385 ohms between pin **85** and pin **86** on relay.
- h. **IF** resistance in Steps 5.f or 5.g were **UNSATISFACTORY**, **THEN REPLACE** seawater relay.
- i. **IF** seawater pump relay replaced in Steps 5.d or 5.h, **THEN RECONNECT** all connections, **POWER** Seakeeper **AND CHECK** Code 16 alarm clear.

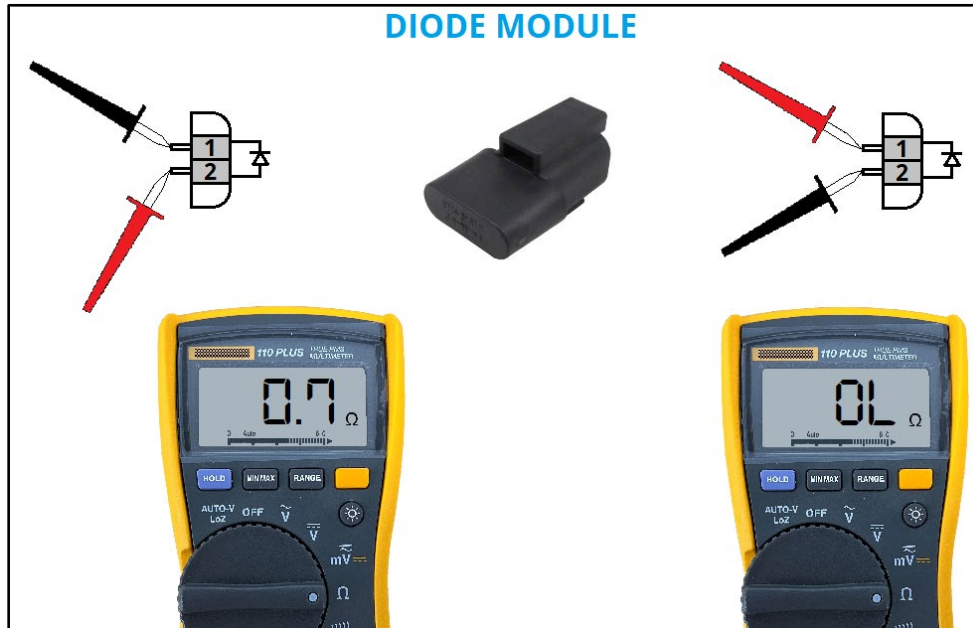
6. **TEST** diode module as follows **[N/A on DC Models]**:

- a. **UNPLUG** diode module from wire harness.
- b. With multimeter in resistance mode, **TEST** for high (OPEN LOOP) resistance in one direction **AND** 0.5 to 0.8-ohm resistance in other direction on two pins of diode module.
- c. **IF** both resistances measured are high or "OL," **THEN REPLACE** diode module.
- d. **IF** both resistances measured are relatively low (continuity in both directions), **THEN REPLACE** diode module.

7. **TEST** wire harness as follows:
- a. **ENSURE** DC control power and seawater pump supply breakers are OFF.
 - b. **DISCONNECT** 70-Pin GCM connector from GCM.
 - c. **TEST** for 0.3Ω or less as follows:
 - i. **TEST** for resistance between Pin 2 of *DC SW Pump In* connector AND Pin 2 of *DC SW Pump Out* connector.

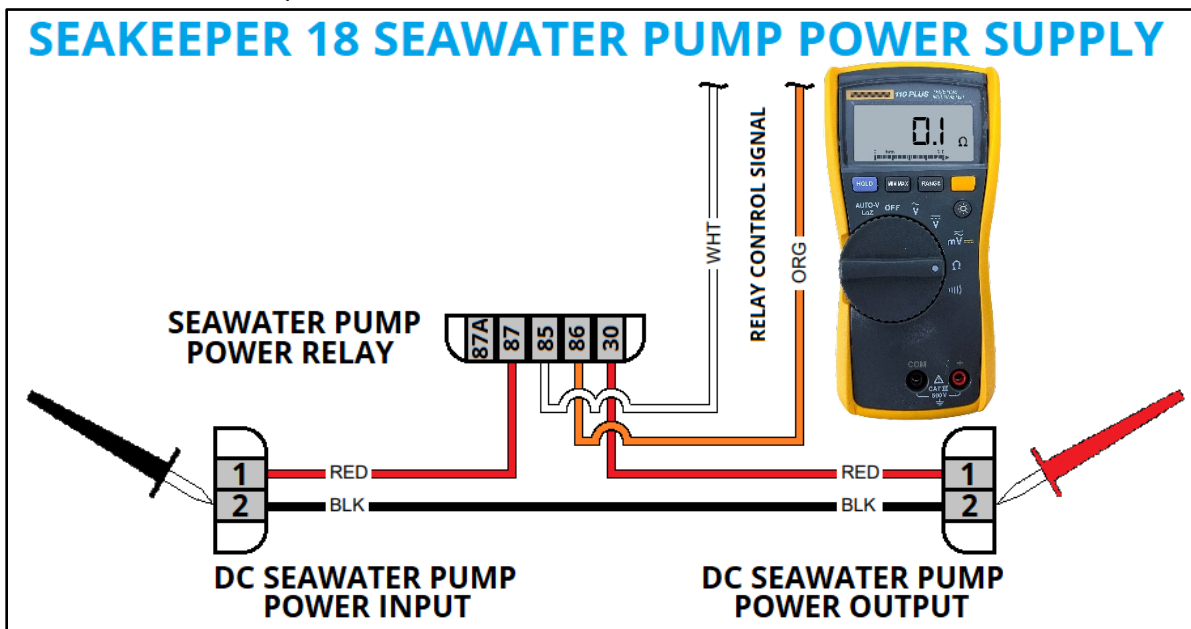

Step 7.c continued

- ii. **TEST** for 0.3Ω or less between Pin **1** of *DC SW Pump In* connector and Pin **87** of seawater pump power relay connector.

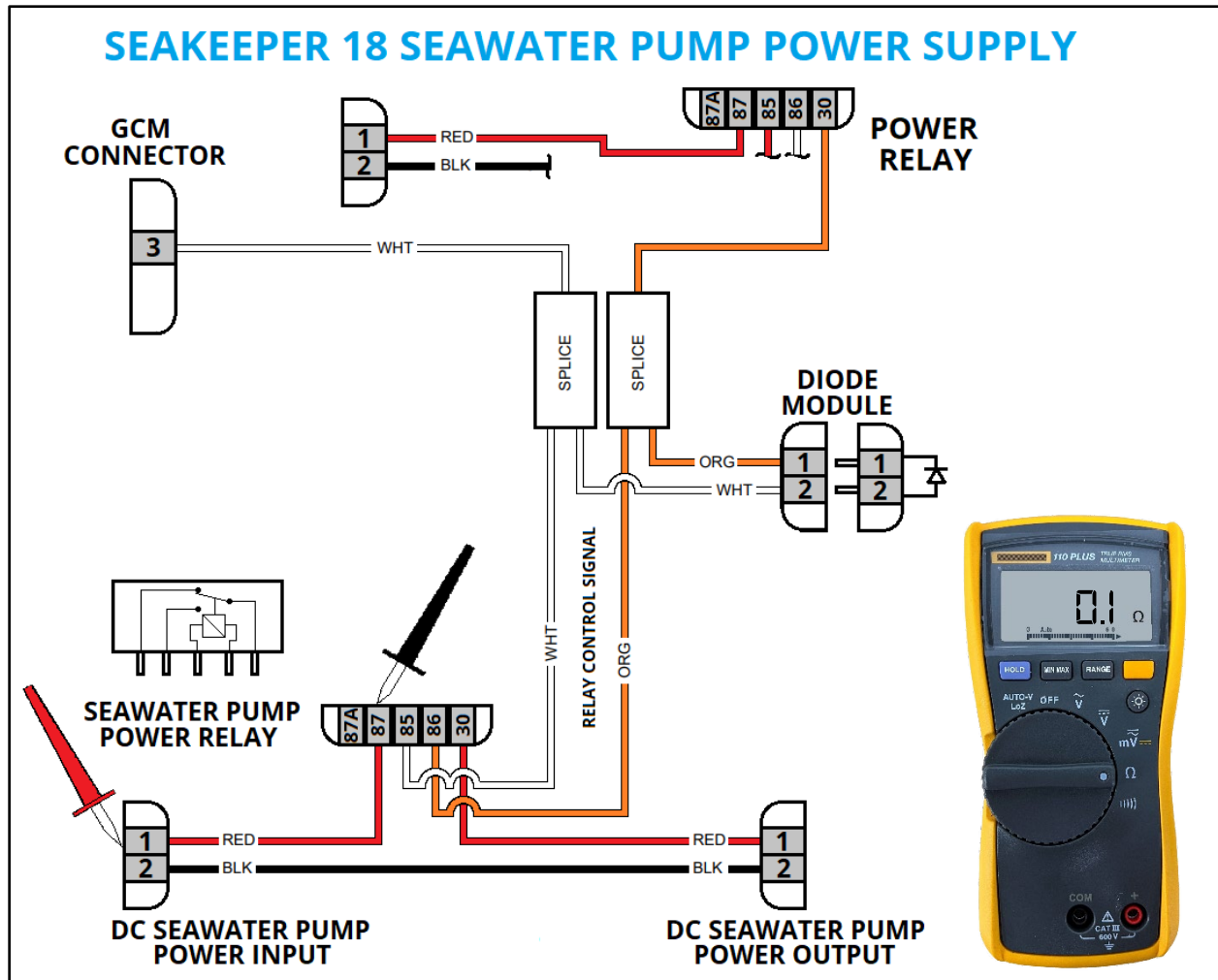

Step 7.c continued

- iii. **TEST** for 0.3Ω or less between Pin **30** of seawater pump power relay connector and Pin **1** of *DC SW Pump Out* connector.

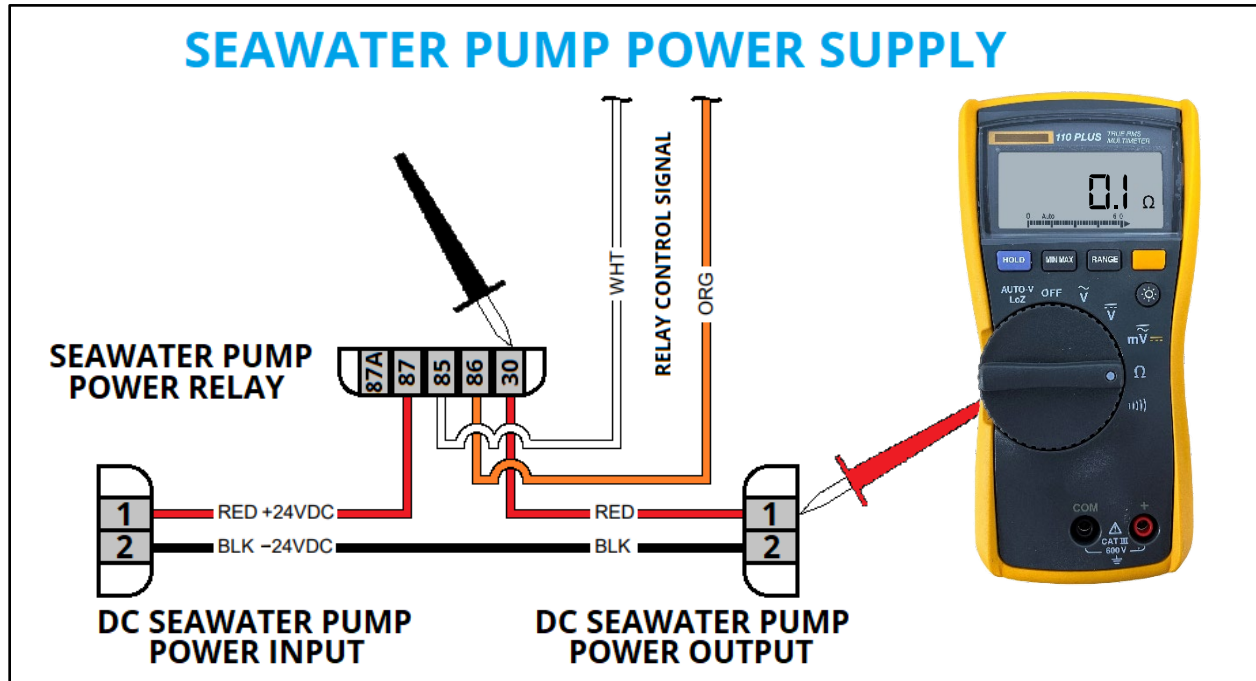

Step 7.c continued

- iv. **TEST** for 0.3Ω or less between Pin **85** of seawater pump power relay connector and Pin **3** (4 on Seakeeper 2 & 3) of 70-pin GCM connector.

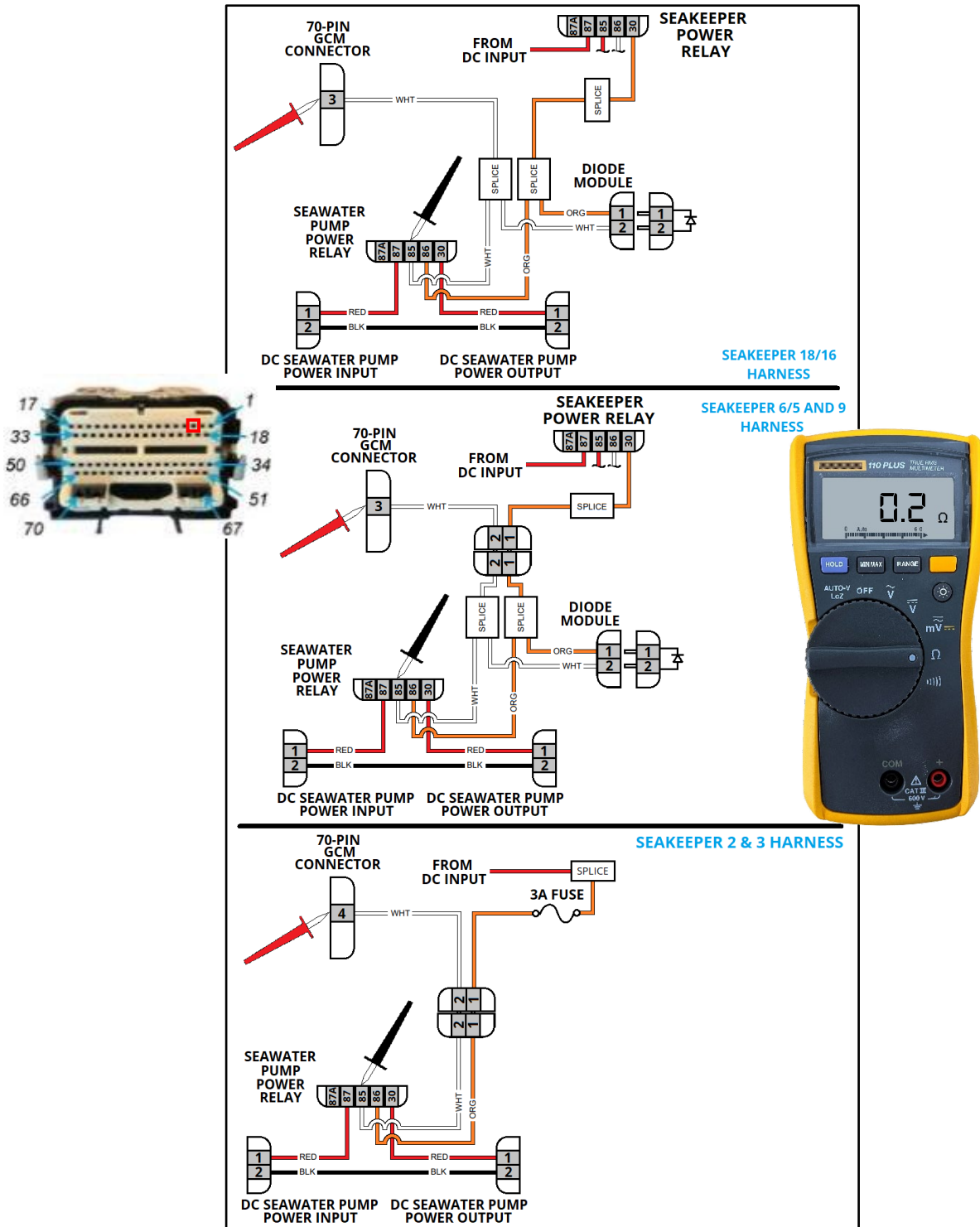

Step 7.c continued

- v. On AC models, **TEST** for 0.3Ω or less between Pin **85** of seawater pump power relay connector and Pin **2** of diode module connector.

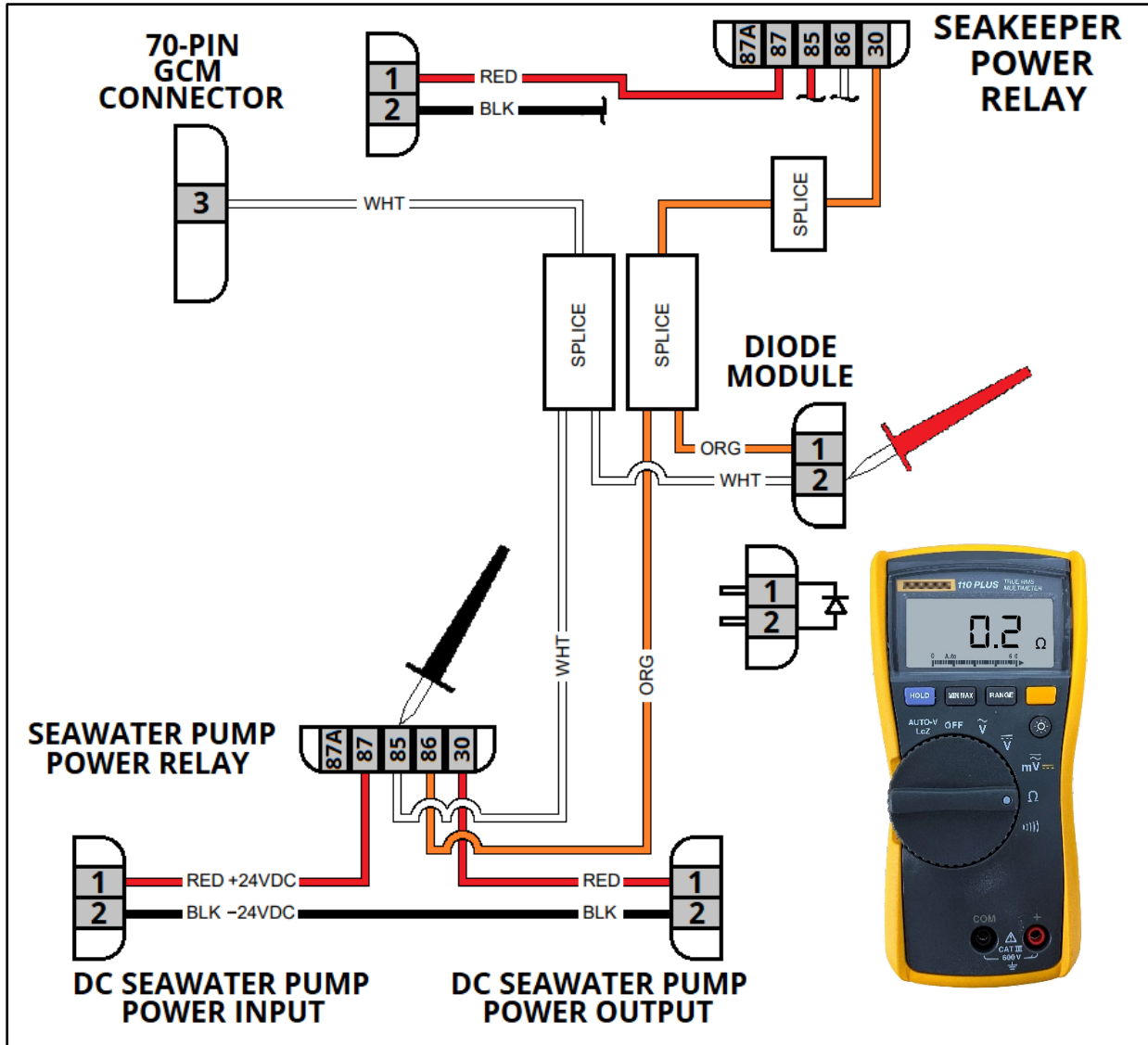

Step 7.c continued

- vi. On AC models, **TEST** for 0.3Ω or less between Pin **86** of seawater pump power relay connector and Pin **1** of diode module.

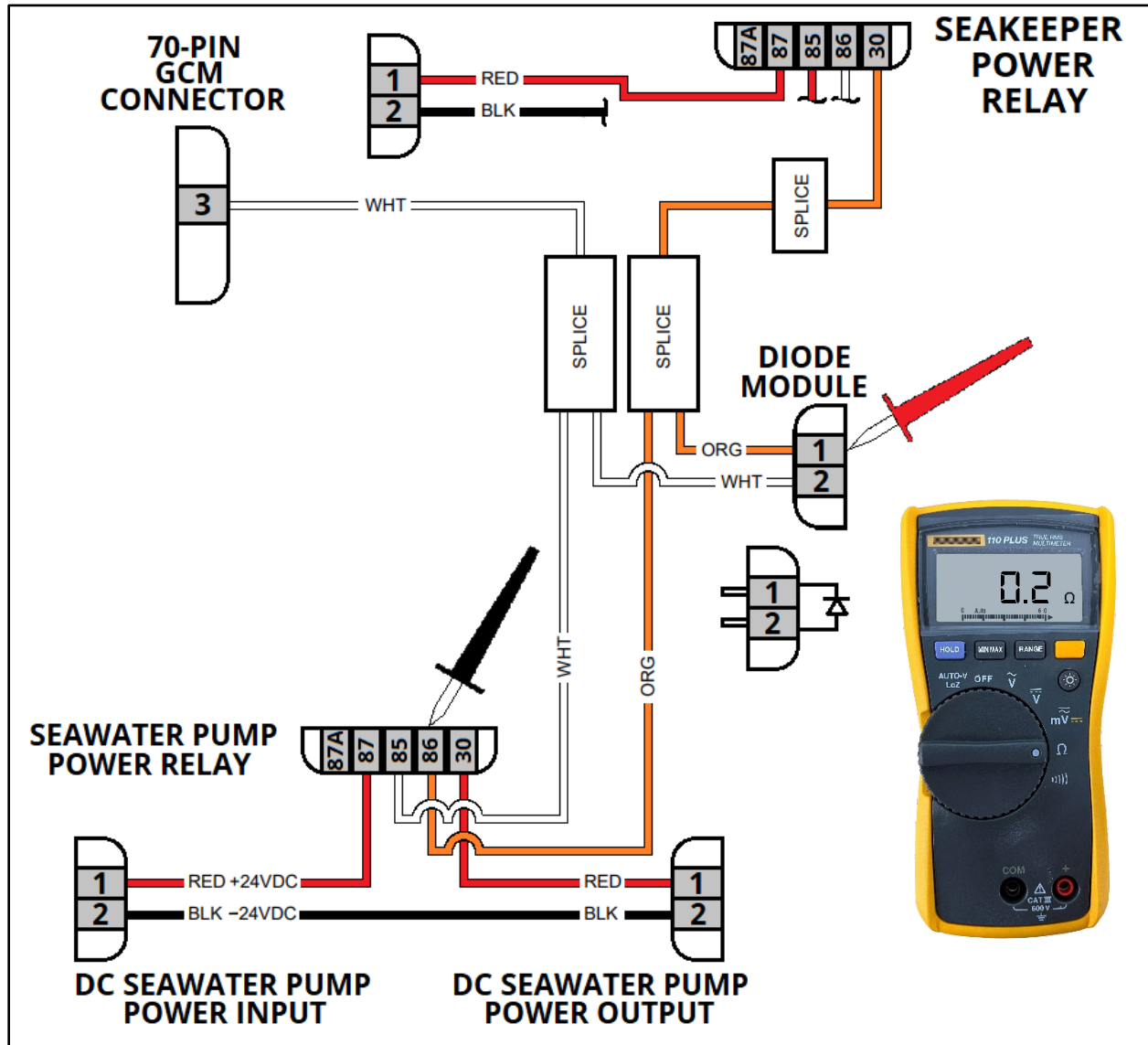

- 8. **IF ANY** test of Step 7.c is UNSATISFACTORY, **THEN REPLACE** seawater switching harness.

SEAKEEPER TROUBLESHOOTING GUIDE - 106



PRODUCT SEAKEEPER SERIES MODELS

Code 16

9. **IF** previous steps showed no faults,
THEN REPLACE GCM.
10. After replacing GCM, **CHECK** Code 16, Discrete Seawater Pump Fault clear.
11. **IF** alarm persists,
THEN CONTACT Seakeeper Product Support Team at support@seakeeper.com with all data collected from testing and summary of steps taken.

******* END *******

PRODUCT SEAKEEPER SERIES MODELS

**CODE 73/74**

To troubleshoot and repair an UPPER/LOWER BEARING TEMP HIGH alarm (Code 73 or 74).

For Codes 150 through 153 (Sensor Fault codes), see [Code 150-153/165](#).

BACKGROUND

Either code is activated by the Seakeeper 5/3DC (up to S/N 5-1049) and 9/7HD through 35/30HD when the upper bearing temperature thermistor (Code 73) or the lower bearing temperature thermistor (Code 74) senses a temperature higher than 70°C (158°F). The alarm will clear once the temperature drops below 60°C (140°F).

When a bearing temperature thermistor fails electrically (open in the circuit), or the actual sensed temperature rises above the sensor's range, the display latches at a bearing temperature of 50°C (122°F) until the issue resolved and DC power is cycled the Seakeeper will operate as usual. DC power must be cycled for the GCM to find the thermistor any time the thermistor is removed and reconnected. Thermistor electrical faults are covered by Codes 150, 151, 152 and 153. These warning codes will not affect operation.

Troubleshooting will guide the technician to inspect the thermistor wiring and connections first; this is more likely the cause of an alarm. Secondly, the guide will check the glycol cooling system. If a Code 8/9: Coolant Pump Fault or a Code 6: Motor Drive Temp High accompanies either of these codes, the best course is to follow the Code 8/9 Troubleshooting Guide or the Code 6 Troubleshooting Guide to correct this code. If the bearing temperature remains in alarm afterward, return to this guide to address the bearing issue.

REFERENCES

[SWI-107 - Glycol Service work instruction](#)

PRECAUTIONS

See [PRECAUTIONS](#) of Introduction section.

PROCEDURE

1. **IF** Seakeeper was recently operated, **THEN NOTE** all temperatures of components to determine if cooling issue or if bearing issue.
2. At bearing temperature thermistor on enclosure, **CONFIRM** electrical connections are made securely.

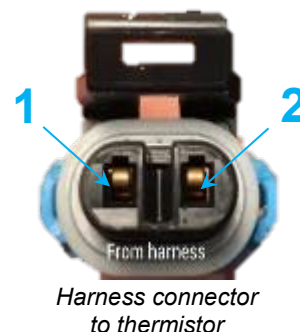
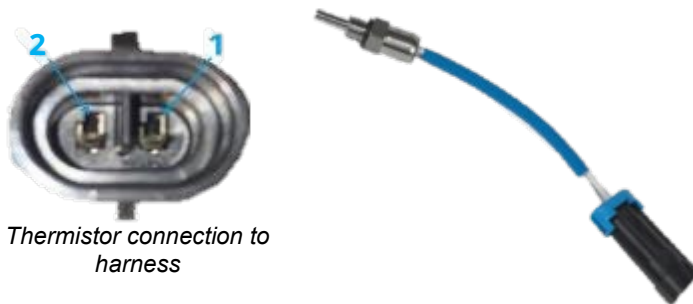

- a. **IF** connection loose, **THEN RECONNECT** any loose connection.
 - b. Momentarily (5 seconds or longer) **CYCLE** DC Control Power to Seakeeper.
 - c. **SPOOL** Seakeeper.
 - d. **VERIFY** all alarms clear.
3. **UNPLUG** affected thermistor from wire harness.
 4. With a multimeter, **VERIFY** resistance between two pins (of sensor) is between 1000Ω and 50,000Ω.

Resistance vs. Temperature			
Temperature °C / °F	Resistance (Ω)	Resistance Tolerance (±%)	Tolerance ±°C / °F
25 / 77	10,000	5.00	1.14 / 2
85 / 185	1070	6.77	2.15 / 4



Meter in this photo is displaying 11.05 KΩ.

- a. **IF** resistance is higher than 50,000Ω **OR** less than 1000Ω, **THEN REPLACE** thermistor.
- b. Momentarily **CYCLE** DC Control Power to Seakeeper.
- c. **SPOOL** unit **AND VERIFY** alarm clear at display.

5. **REMOVE AND SWAP** affected thermistor with opposite thermistor’s harness connection.
 - a. Momentarily **CYCLE** DC power to Seakeeper.
 - b. **IF** unaffected sensor is now in alarm (e.g., Code 73 was originally in alarm. After re-energizing control power, Code 74 is in alarm), **THEN REPLACE** first thermistor.

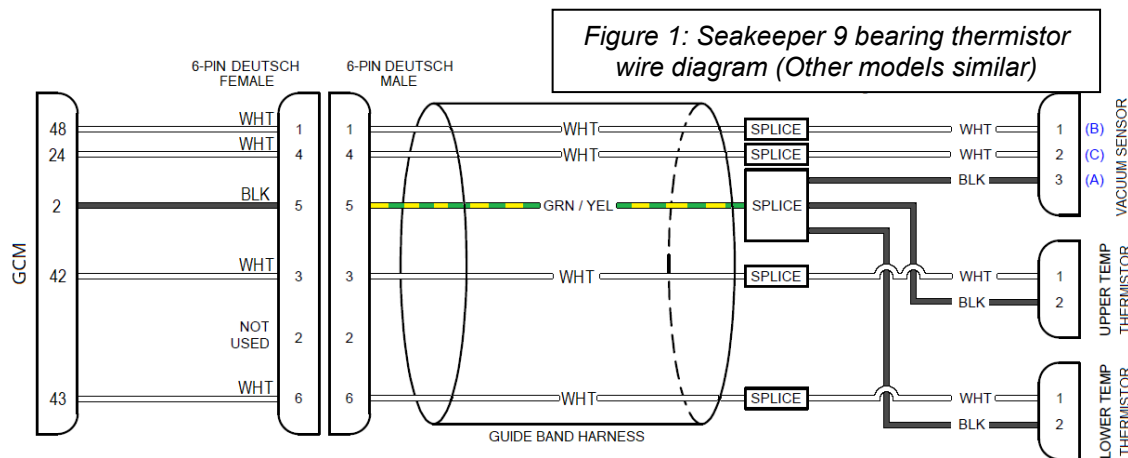

NOTE:

Thermistors are assembled with small amount of Timtronics® White Ice 510 thermal conductive paste applied to sensor tips.



- c. **RESTORE** original electrical configuration – Lower Bearing Temperature connector attached to lower bearing sensor and Upper Bearing Temperature connector attached to upper sensor.

6. With a multimeter and DC power connected, **MEASURE** voltage across two pins of harness connector of thermistor (see figure 1). Note: Voltage should be around 5VDC.

- a. **IF** no voltage sensed across two pins, **THEN LOCATE AND DISCONNECT** guide band connection near rear of foundation.

Figure 2: Foundation wire harness diagram from guide band to GCM

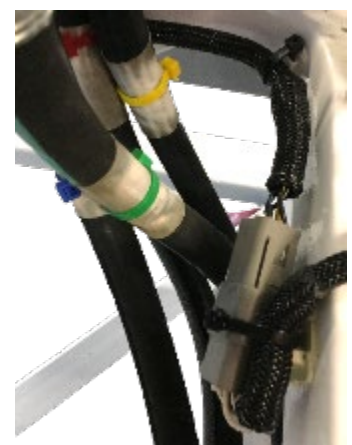
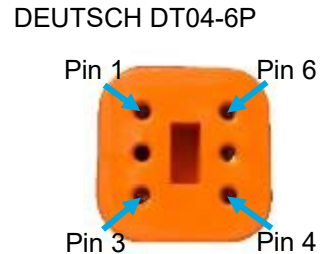
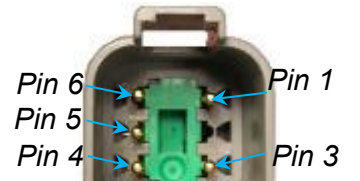
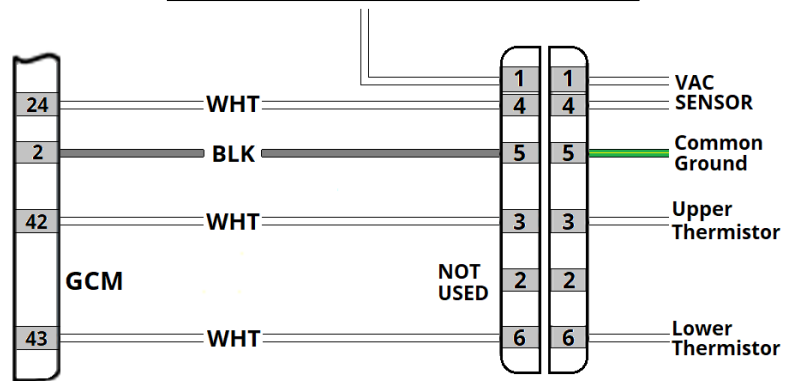

Photo showing location of Guide Band connector inside foundation near guide band bracket and below manifold.

- b. **WHILE** performing next two steps, **PRECESS** enclosure to each end stop and near 0° precession to take readings.
- c. On guide band harness, **CONFIRM** 0.3Ω or less between affected sensor's harness connector pin 1 and guide band connector Pin 3 (for Upper Thermistor) or pin 6 (for Lower Thermistor).
- d. On guide band harness, **CONFIRM** 0.3Ω or less between effected sensor's harness connector pin 2 and guide band connector Pin 5.

Step 6 continued

- e. **IF** either measurement in Step 6.c or 6.d results in a high resistance or no continuity, **THEN REPLACE** guide band wire harness.
- i. **CYCLE** DC Control Power to Seakeeper.
 - ii. **SPOOL** Seakeeper.
 - iii. **VERIFY** all alarms clear.
- f. **IF** continuity found in both 6.c and 6.d, **THEN PERFORM** following measurements:

- i. **ENSURE** DC Control Power disconnected.
- ii. **CONFIRM** 0.3Ω or less between foundation wire harness connector at guide band and GCM 70-pin connector as follows:

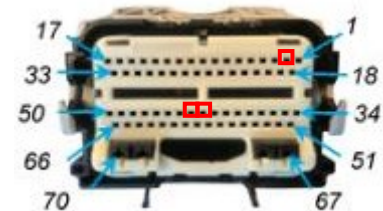

1. **IF** Lower Thermistor is effected sensor, **THEN CONFIRM** 0.3Ω or less between female pin **6** of foundation wire harness to guide band connector and GCM pin **43**.
 2. **IF** Upper Thermistor is effected sensor, **THEN CONFIRM** 0.3Ω or less between female pin **3** of foundation wire harness to guide band connector and GCM pin **42**.
 3. **MEASURE** between female pin **5** of foundation wire harness to guide band connector and GCM pin **2**.
- iii. **IF** any measurement of Step 6.f.ii showed resistance greater than 0.3Ω , **THEN REPLACE** wire harness.
1. Once replaced, **CYCLE** DC control power to Seakeeper.
 2. **SPOOL** Seakeeper.
 3. **VERIFY** all alarms clear.

CAUTION:

GLYCOL PUMP DAMAGE MAY OCCUR if run without visible glycol in reservoir.

7. **ACTIVATE** Glycol Override to circulate coolant.
8. **REMOVE** reservoir filler cap **AND OBSERVE** turbulent flow at filler neck.

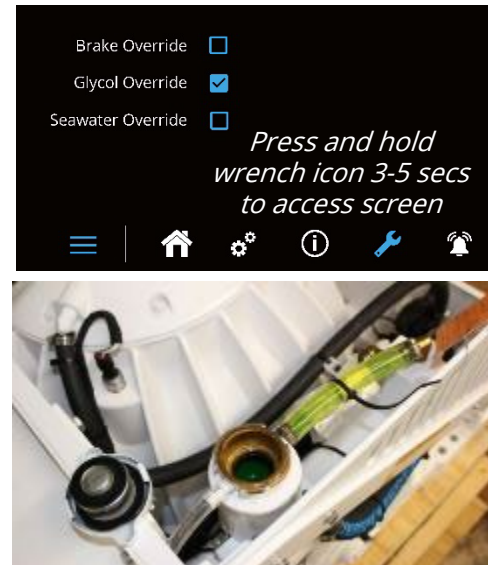

- a. **IF** turbulent flow not seen, **THEN FEEL** glycol pump discharge line for flow.
 - b. **IF** no turbulence was seen/flow felt, **THEN TROUBLESHOOT** glycol pump failure per [Code 8/9 Troubleshooting Guide](#).
9. **RE-ENERGIZE AND SPOOL** Seakeeper.
 10. **IF** all previous steps failed to clear alarm, **THEN:**
 - a. **ENSURE** all power removed from Seakeeper.
 - b. **REPLACE** GCM.
 - c. **ALIGN** power to Seakeeper.
 - d. **SPOOL** Seakeeper **AND VERIFY** all alarms clear.
 11. **IF** all alarms clear, **THEN SEA TRIAL** Seakeeper to ensure all issues addressed, if possible.
 12. **IF** alarm persists, **THEN SUBMIT** all data collected to support@seakeeper.com.

******* END *******

PRODUCT SEAKEEPER SERIES MODELS

**CODE 105/161/162**

To troubleshoot and clear:

“HEATER DELAYS DRIVER” warning (Code 105)

“HEATER INEFFECTIVE WARNING” (Code 161)

“HEATER NOT PRESENT” warning (Code 162).

BACKGROUND

These warnings are only enabled on the Seakeeper 26 and 35 models. The warnings alert the operator of an adverse condition with the optional heater accessory (P/N 20238) available to these models.

Code 161 is activated after a timer, based on initial temperature, runs out. The GCM programming includes a starting temperature table and determines the required heater run-time to achieve a normal start temperature. If the ideal temperature has not been reached at the end of the timer, the code 161 will trigger. After waiting a set period, the Seakeeper will attempt to spool up regardless of bearing temperature. In this condition, the flywheel could accelerate very slowly due to high bearing loading if the bearings cannot float in their housings. Troubleshooting must focus on the heater control and power supply to remedy the code.

Code 162 is triggered when a heater plugged into the heater connector is unplugged at one point. The GCM must have detected a heater was present at some point. Failure to detect a heater may occur on an affected model when a load is plugged into the heater control plug for at least 60 seconds. (For example, a technician plugs a glycol pump into the heater connector to test a harness.) Once this happens, the GCM internally sets a flag that activates the “HEATER NOT PRESENT” warning when the load is unplugged. This warning can be triggered even if a unit is not fitted with a heater.

REFERENCES

90322 - Seakeeper 26 & 35 Heater Instruction Manual (available upon request)

20246 - 24VDC Heater Control Box Assembly drawing (available upon request)

PRECAUTIONS

See [PRECAUTIONS](#) of Introduction section.

PROCEDURE

1. **VERIFY** separate 230VAC, 20 amp breaker for heater is **ON** and not tripped.
2. **VERIFY** electrical connections associated with heater assembly are made.
 - a. **IF** unit equipped with heater,
THEN:
 - i. **VERIFY** the heater and harness connectors at right rear of unit (near guide band connector, beneath GCM) is made securely.



- ii. **CYCLE** 24VDC supply to Seakeeper.
 - b. **IF** unit is NOT equipped with heater,
THEN:
 - i. **VERIFY** no load is connected to harness heater connector.
 - ii. **CYCLE** 24VDC supply to Seakeeper.
 - iii. **CHECK** harness connectors for corrosion.
3. **TURN OFF** 24VDC supply breaker to Seakeeper.

**WARNING:**

PERSONNEL SHOCK HAZARD EXISTS in heater control box when energized.

4. **TURN OFF** 230VAC breaker for Seakeeper **AND** heater.
5. **DISCONNECT** GCM 70-pin connector from GCM.

6. **DISCONNECT** main power relay from wire harness.
7. With multimeter, **VERIFY** continuity within wire harness to heater connector:

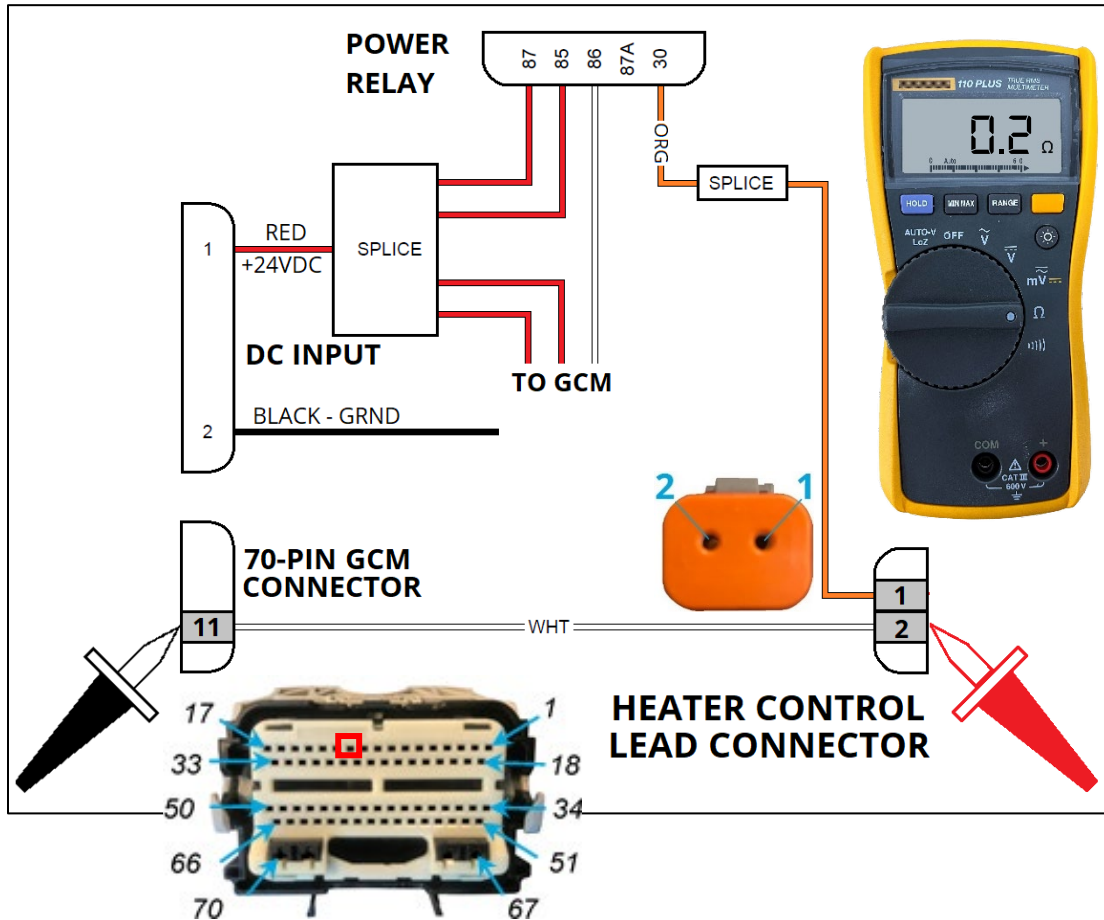

- a. **VERIFY** 0.3Ω or less between GCM pin 11 and heater connector pin 2.
- b. **VERIFY** 0.3Ω or less between power relay connector pin 30 and heater connector pin 1.

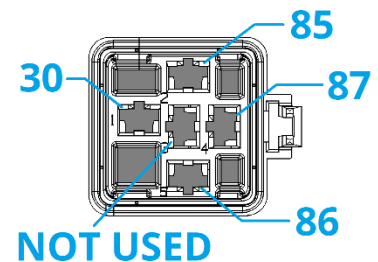

PRODUCT SEAKEEPER SERIES MODELS

Code 105/161/162

8. **IF** resistance check(s) were UNSATISFACTORY, **THEN:**
 - a. **VERIFY** wires and crimps of harness heater connector are secure.
 - b. **VERIFY** wire and crimp of pin **11** of GCM 70-pin connector is secure.
 - c. **IF** wires and crimps SATISFACTORY, **THEN REPLACE** wire harness.
 - d. **CONTINUE** in procedure.

9. **OPEN** heater control box with Phillips head screwdriver.

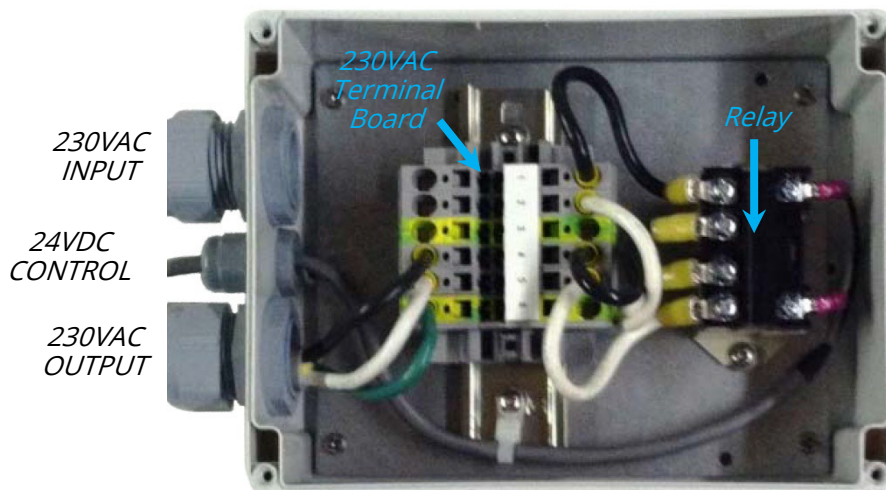
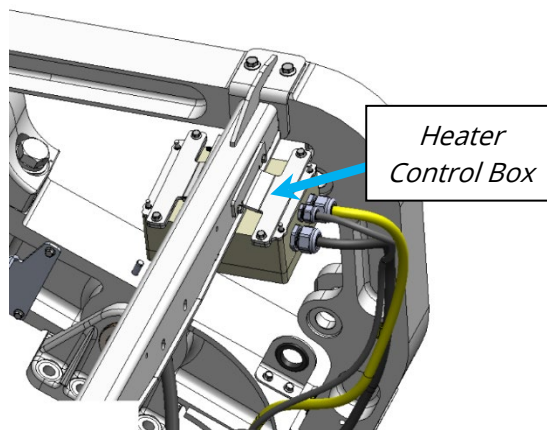
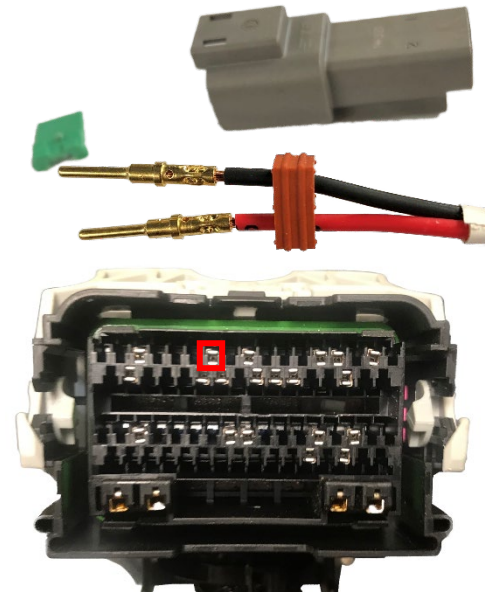

10. With multimeter, **VERIFY** resistance in the heater control cable from harness:
- VERIFY** 0.3Ω or less between relay coil terminal **0** (blue wire) and heater connector pin **2**.

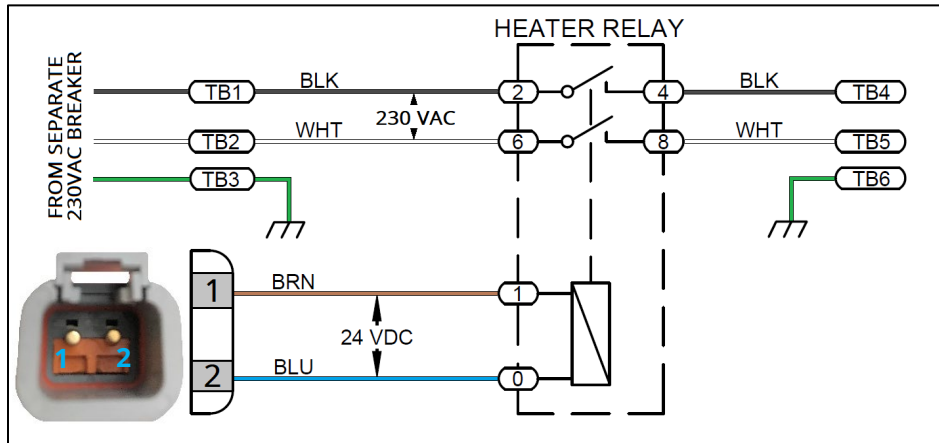

- VERIFY** 0.3Ω or less between relay coil terminal **1** (brown wire) and heater connector Pin **1**.
- IF** resistance checks of heater control cable **UNSATISFACTORY**, **THEN CONTACT** Seakeeper Product Support Team at support@seakeeper.com with all data collected.

**WARNING:**

PERSONNEL SHOCK HAZARD EXISTS in heater control box when energized.

11. **IF** code 161 persists,
THEN:

- a. **TURN ON** 230VAC heater supply breaker to align power to heater.
- b. **MEASURE** voltage at heater control box between terminals **1** and **2**.

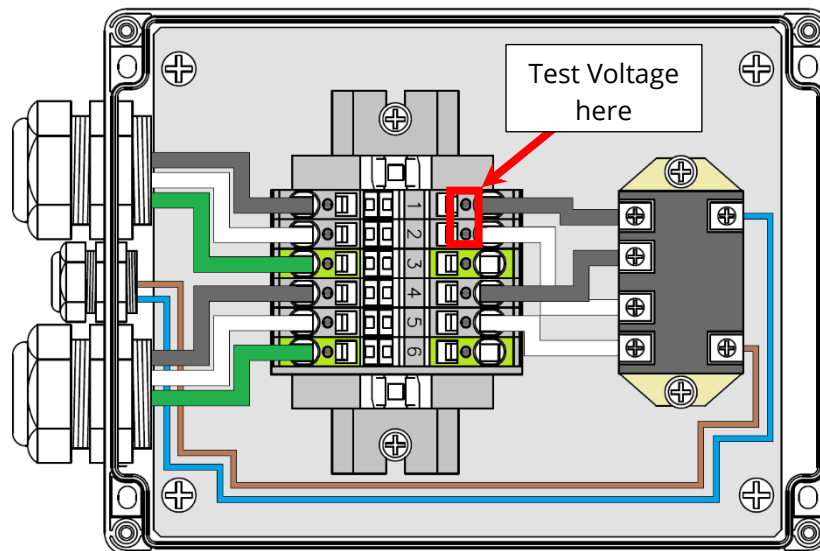

- c. **IF** voltage abnormal,
THEN TROUBLESHOOT vessel breaker and supply cable.

12. **IF** alarm persists,
THEN CONTACT Seakeeper Product Support Team at support@seakeeper.com with results of testing and any photos.

***** **END** *****

PRODUCT SEAKEEPER SERIES MODELS

CODE 35/251 △

To diagnose and repair the “DISPLAY FAULT” alarm (Code 35) or the similar “NO CONNECTION TO GYRO” alarm (Code 251).

BACKGROUND

The “Display Fault” alarm (Code 35) may appear on the display whenever the GCM has lost communication with the display(s). The reset condition is for communications to be returned to the display for one minute. When the alarm is activated by the GCM (seen by the display or not), the Seakeeper will continue to run as normal for about 30 seconds. Afterward, the Seakeeper will spool down, and the brakes locked. When the display is reconnected with Seakeeper, the alarm will appear on the display and should clear immediately with a press of the POWER button.

The “No Connection to Gyro” alarm (Code 251) is very similar to Code 35 and is included in this troubleshooting. This alarm is produced (but may not be seen by the operator because of a failed display) when there is a loss of all communication in the wiring of the Controller Area Network of the Seakeeper: either by an OPEN in the wiring or a SHORT. The latter has even produced Code 75 (IMU FAULT) and Code 251, during testing. The “No Connection to Gyro” alarm reacts like most alarm responses: immediately removing power and locking the stabilizer.

Multifunction displays (MFDs) connected to Seakeeper models with a ConnectBox have shown Code 251. Technicians may erroneously replace the ethernet or MFD adapter cable to clear the issue. If the Seakeeper-to-MFD link (Ethernet adapter cable and MFD adapter cable) were faulty, the Seakeeper MFD web app should fail to open or set web app exception overlays. The Code 251 suggests the issue is in the connection between the ConnectBox and the GCM; it is most likely due to connection issues or failure of the T-Adapter, Terminator (resistor), ConnectBox-to-Tee adapter cable or ConnectBox ports being damaged.

A common cause for this alarm is the loosening of a display cable connection, terminal resistor, or T-adapter. Other causes can be updating display software, a failure in the display plug, or GCM connection issues. This alarm may result from tight bend radii (less than 1-1/2 in. (36 mm) bend radius) or crushing of the display cable that may have damaged the internal conductors.

REFERENCES

Applicable Seakeeper [Cable Block Diagram](#)

[SB-90504 - CAN Correction Service Bulletin](#)

[TB-90637 - Code 251 Connectivity Issues Update](#)

PRECAUTIONS

see [PRECAUTIONS](#) section of Introduction.

PROCEDURE

1. **IF** vessel has experienced lightning strike or electrical surge just before alarm **AND** other electrical appliances have been affected, **THEN CONTACT** Seakeeper Product Support Team at support@seakeeper.com.
2. **IF** display software was recently updated, **THEN CYCLE** low current DC input to Seakeeper.

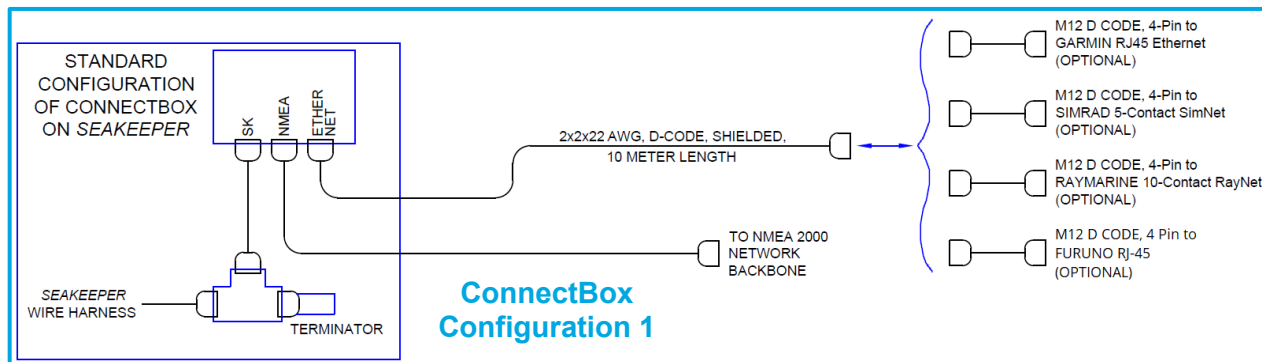
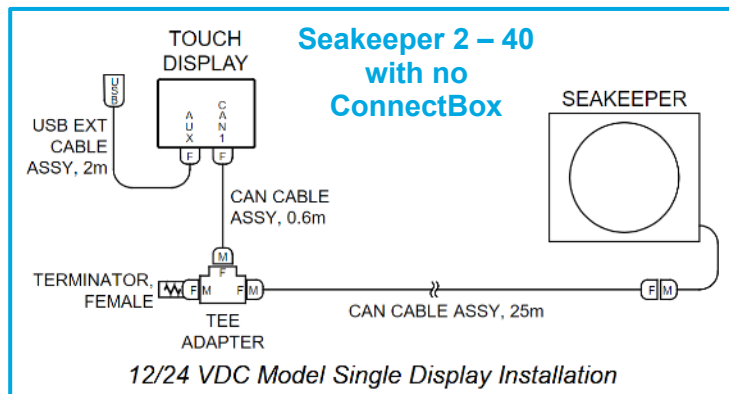
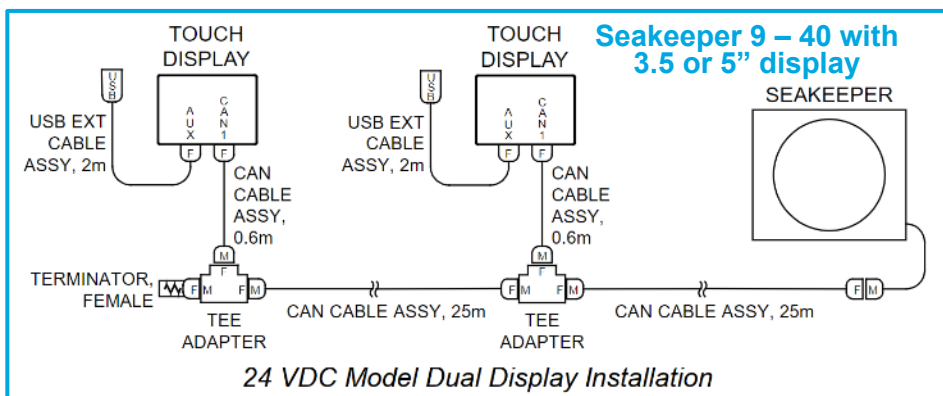

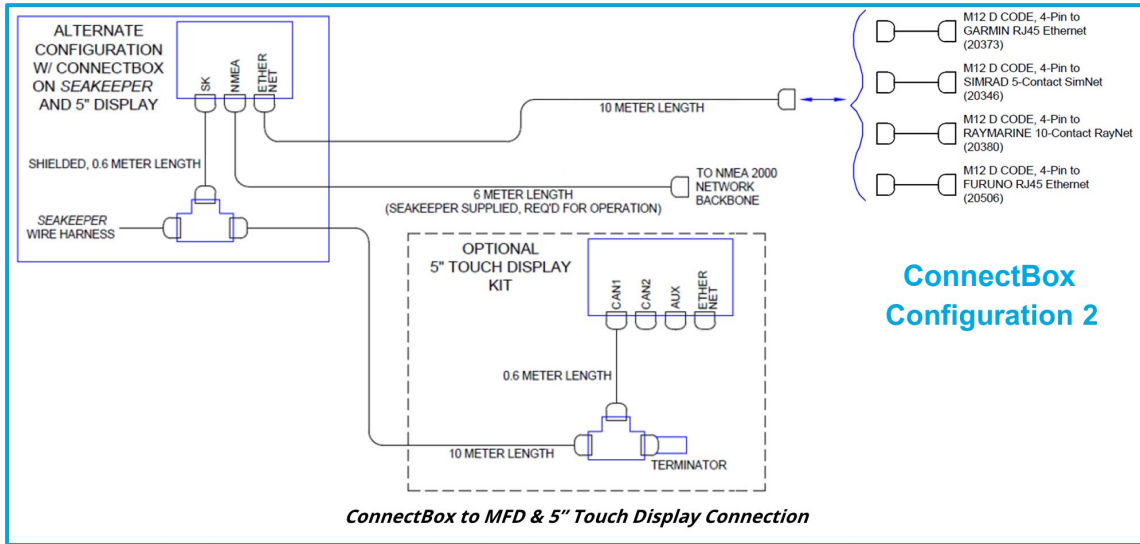

ConnectBox to MFD & 5" Touch Display Connection

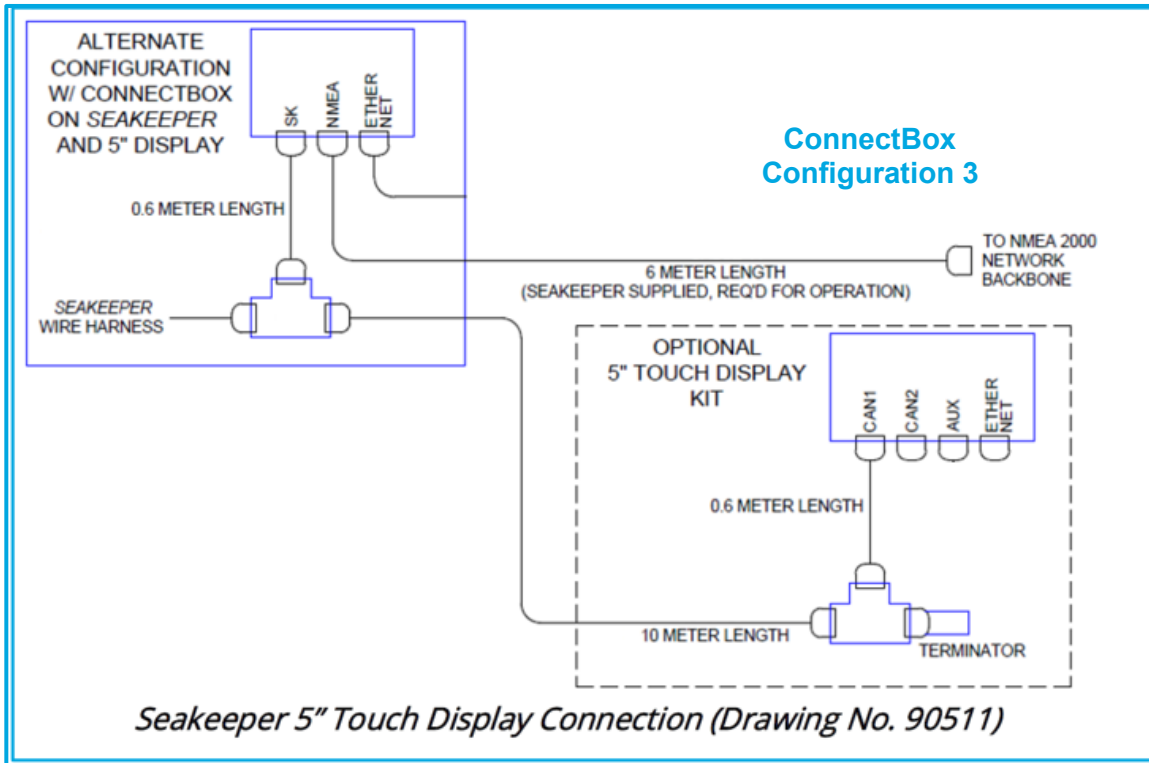

Seakeeper 5" Touch Display Connection (Drawing No. 90511)

3. **IF** spare display **of same design** (i.e., 3.5-inch for 3.5-inch display) available, **THEN CONNECT** spare display in place of installed display.



ConnectBox

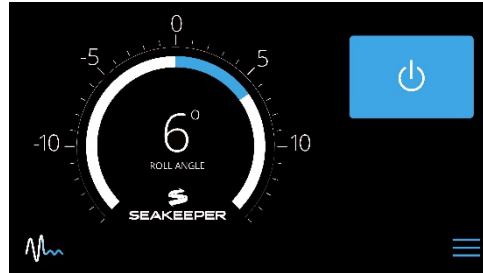

5" Touch Display



3.5" Display

- a. **IF** alarm will clear and ALL data from Information screen populated, **THEN REPLACE** installed display.
4. **INSPECT** all CANbus cable connections as follows:
- a. **VERIFY** following:
- i. **GO TO** Helm Station(s) (Seakeeper with optional helm mounted ConnectBox or 5" display):
1. **VERIFY** CANbus cable from Seakeeper is correctly threaded into T-adapter.
 2. **VERIFY** terminator is correctly threaded into T-adapter of a second display or only single display attached to system.
 3. **VERIFY** display cable from display/ConnectBox is threaded correctly into T-adapter.
 4. **IF** helm display is a 5-inch display and shows color blocks (as shown), **THEN UPDATE** display(s) software with latest software release.

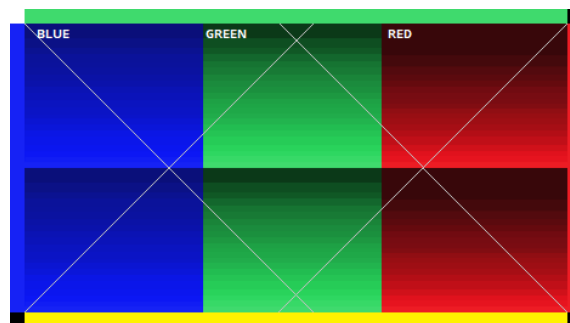

5. **CHECK** alarm cleared.

Step 4.a continued

NOTE:

5" display is used as spare display on ConnectBox-equipped models.

ii. **GO TO** Seakeeper:

1. **VERIFY** display cable correctly threaded to display output cable.
2. **CONNECT** spare display into CAN cable from Seakeeper.
3. **IF** spare display shows data on Information screen, **THEN REPLACE** CAN cable from Seakeeper to helm.
4. **DISCONNECT** IMU connector from wire harness.
5. **IF** Code 251 clear and data from Information screen populated (except for IMU), **THEN PROCEED** to [step 7.d](#).

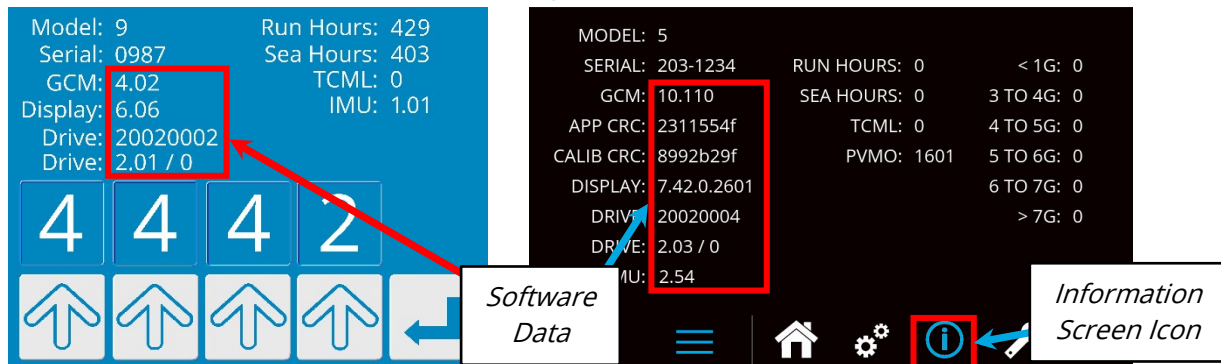
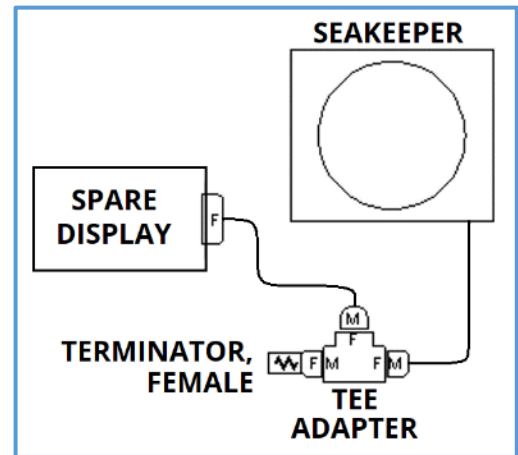

6. **RECONNECT** IMU.
7. **DISCONNECT** MDB connector from wire harness.
8. **IF** Code 251 clear and data from Information screen populated (except for MDB), **THEN PROCEED** to [step 7.e](#).

PRODUCT SEAKEEPER SERIES MODELS

Code 35/251

Step 4.a.ii continued

9. **VERIFY** GCM 70-pin connector is correctly engaged in GCM.
10. **IF** NO spare display is available,
THEN DISCONNECT helm display **AND INSTALL** it locally at Seakeeper output.

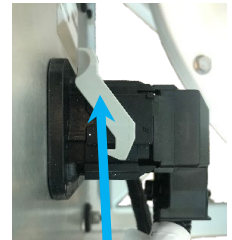

*Securely
connected GCM*

NOTE:

Even though display cable is keyed, it is possible to force it together incorrectly.

- b. **VERIFY** all CAN cable pins not bent and connections made correctly.



- c. **IF** Seakeeper 2 or 3,
THEN VERIFY harness revision as follows:
 - i. On wire harness near GCM on a Seakeeper 2,
VERIFY harness is revision 8 or later. [N/A if 2-0084 or after]
 - ii. On wire harness near GCM on a Seakeeper 3,
VERIFY harness is revision 5 or later. [N/A if 3-0442 or after]
 - iii. **IF** harness is NOT correct revision for model,
THEN PERFORM harness modification per [SB 90504](#).



Harness revision tag for
Seakeeper 2



Harness revision tag for
Seakeeper 3

5. **IF** alarm cleared in step 4 by connection of spare display/ConnectBox, **THEN REPLACE** originally installed display/ConnectBox.

NOTE:

5" display is used as spare display on ConnectBox-equipped models.

6. **IF** no spare display available **OR** alarm did not clear in Step 4, **THEN TEST** for voltage and resistance as follows:
 - a. At Seakeeper unit, **PERFORM** following on CAN cable of harness:
 - i. **VERIFY** 12/24VDC exists between pins 2 & 3.

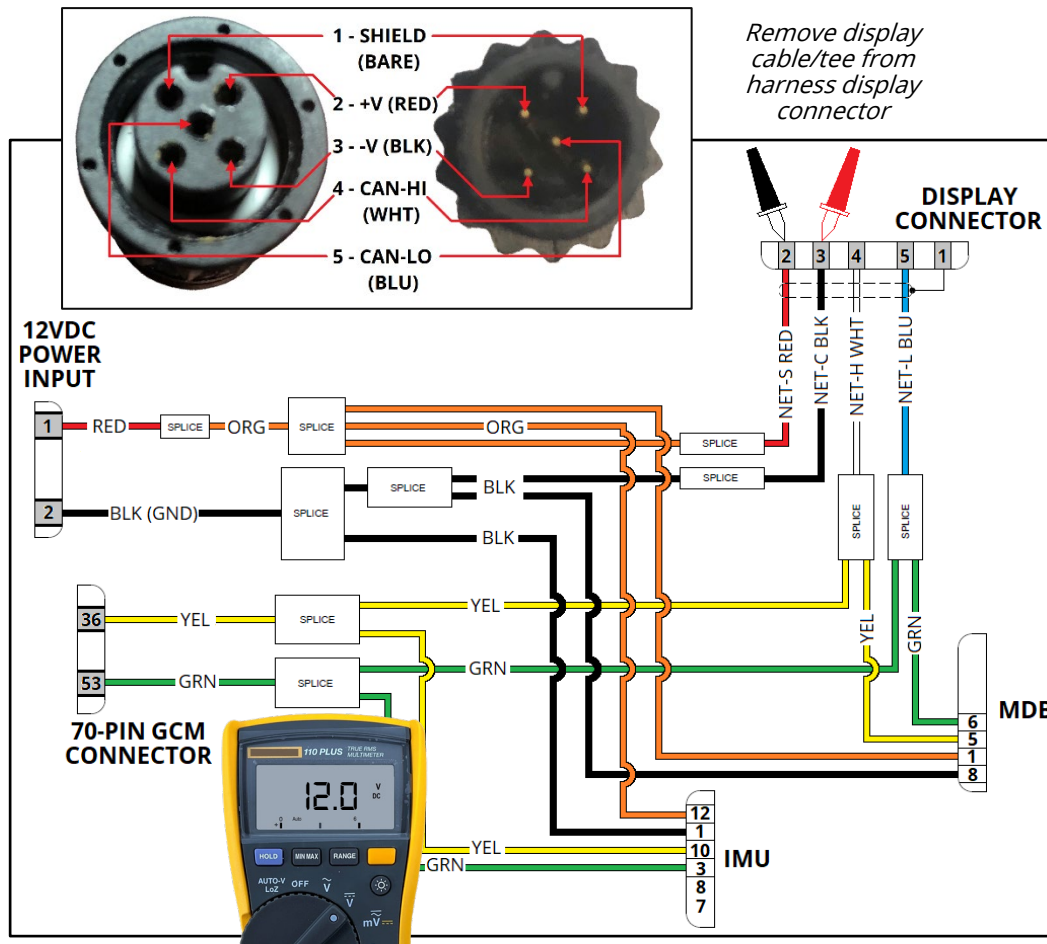

PRODUCT SEAKEEPER SERIES MODELS

Code 35/251

Step 6.a continued

- ii. **TURN OFF** low current DC breaker to Seakeeper.
- iii. **VERIFY** NO short exists between pin **1** and all other pins on CAN cable.
- iv. **VERIFY** resistance of more than 1000Ω exists between pin **5** and pin **2**.
- v. **VERIFY** resistance of more than 1000Ω exists between pin **5** and pin **3**.
- vi. **VERIFY** resistance of more than 1000Ω exists between pin **4** and pin **2**.
- vii. **VERIFY** resistance of more than 1000Ω exists between pin **4** and pin **3**.

NOTE:

If terminating resistor not attached, this resistance will be about 120Ω in this measurement.

- viii. **VERIFY** resistance of 60Ω exists between pin **4** and pin **5**.
 - ix. **IF** any checks in Step 6.a are UNSATISFACTORY, **THEN REPLACE** wire harness.
 - x. **IF** checks of Step 6.a are SATISFACTORY, **THEN CONNECT** display cable from Seakeeper to helm station.
- b. **GO TO** helm station and perform following on display cable from Seakeeper to helm display end connector:
- i. **VERIFY** 12/24VDC exists between pins **2** & **3** at display end of CAN cable at helm.
 - ii. **VERIFY** high resistance (NO short) exists between pin **1** and **all other pins** at display end of cable at helm.
 - iii. **VERIFY** resistance of more than 1000Ω exists between pin **5** and pin **2**.
 - iv. **VERIFY** resistance of more than 1000Ω exists between pin **5** and pin **3**.

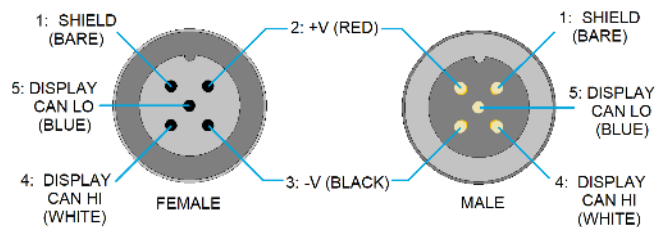

PRODUCT SEAKEEPER SERIES MODELS

Code 35/251

Step 6.b continued

- v. **VERIFY** resistance of more than 1000Ω exists between pin **4** and pin **2**.
- vi. **VERIFY** resistance of more than 1000Ω exists between pin **4** and pin **3**.

NOTE:

If terminating resistor attached, this resistance will be about 60Ω in this measurement.

- vii. **VERIFY** resistance of 60Ω exists between pin **4** and pin **5**.
 - c. **IF** voltage or continuity checks in Step 6.b were **UNSATISFACTORY**, **THEN REPLACE** CAN cable from Seakeeper to helm.
 - d. **IF** Code 35 and alarm persists, **THEN PROCEED** to step 8.
7. **IF** Code 251, **THEN TEST** CANbus components as follows:
- a. **ENSURE** low current DC breaker turned ON.
 - b. **DISCONNECT** IMU and MDB from wire harness.
 - c. **CHECK** active alarms on display:
 - i. **IF** Code 251 cleared (by disconnecting IMU and MDB. Other alarms expected), **THEN PROCEED** to step 7.d.
 - ii. **IF** Code 251 still in alarm (Codes 75 and 82 are expected), **THEN:**
 1. **INSPECT** GCM 70-pin connector for loose pins or crimps.

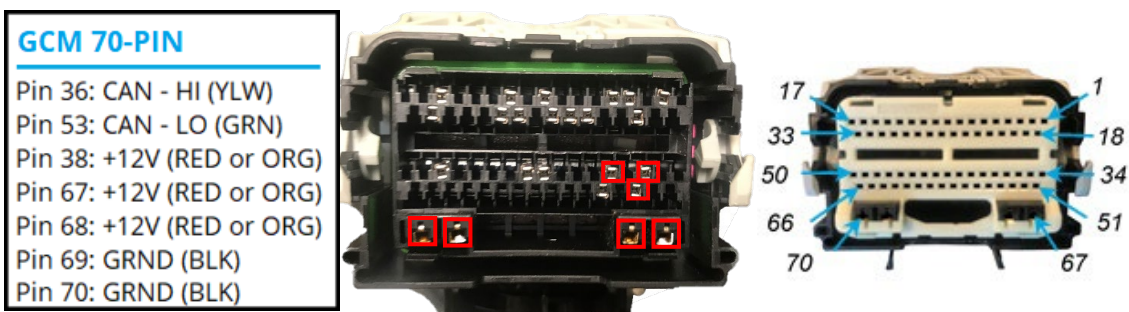

Step 7.c.ii continued

2. **IF** loose pins or crimps found in 70-pin connector, **THEN REPAIR OR REPLACE** wire harness.
3. **TURN OFF** low current DC power to Seakeeper.
4. **INSPECT** GCM for damaged or bent pins.
5. **IF** bent pins found on GCM, **THEN PERFORM** one of following:
 - **STRAIGHTEN** GCM pin(s).
 - **REPLACE** GCM.
6. **TURN ON** low current DC power breaker.
7. With multimeter in DC Volts mode, **CHECK** for 12/24VDC between following pins of GCM 70-pin connector:



GCM 70-PIN CONNECTOR	MODEL VOLTAGES	
Pin 38: +12V (RED or ORG)	Seakeeper 2 thru 6	12 V
Pin 67: +12V (RED or ORG)	Seakeeper 9 thru 40	24 V
Pin 68: +12V (red or ORG)		
Pin 69: GRND (BLK)		
Pin 70: GRND (BLK)		

- a) Pin **38** and:
 - Pin **69**
 - Pin **70**
- b) **[N/A for AC-powered models]**
Pin **67** and:
 - Pin **69**
 - Pin **70**
- c) Pin **68** and:
 - Pin **69**
 - Pin **70**
- d) **IF** no voltage seen in any check of Step 7.c.ii.7, **THEN REPLACE** wire harness.

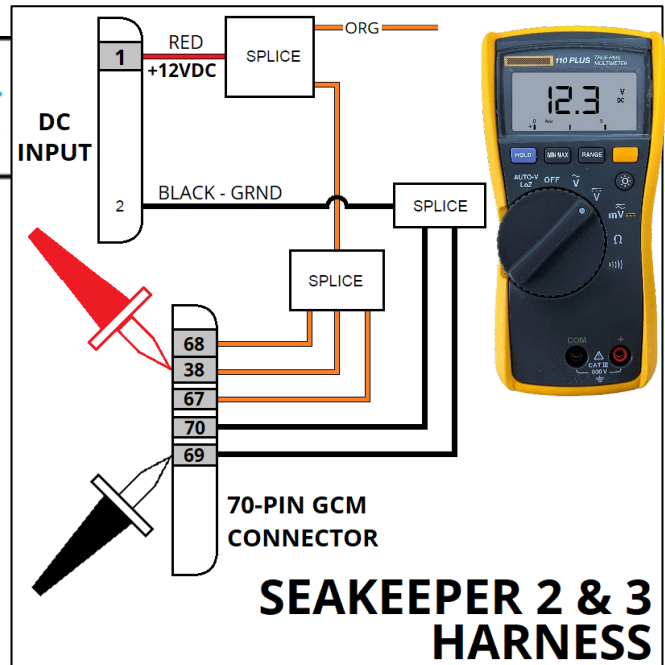

iii. **RECONNECT** GCM 70-pin connector.

Step 7 continued

d. **PERFORM** following at IMU:

- i. In harness IMU connector, **CHECK** for 120 Ω resistance between CANbus pins **3** and **10**.
- ii. **IF** resistance higher or Open Loop, **THEN REPLACE** wire harness.
- iii. **RECONNECT** IMU connector to IMU.
- iv. **IF** code 251 remains clear (Code 82 expected), **THEN PROCEED** to step 7.e.
- v. **IF** code 251 alarm returns (Code 82 expected), **THEN:**

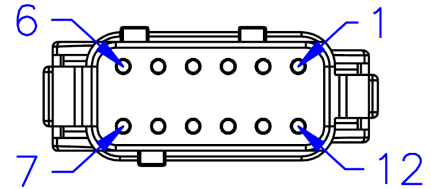

- 1. **INSPECT** 12-pin connector for loose pins and crimps on pins.



- 2. **INSPECT** IMU pins for damaged or bent pins.
- 3. **IF** revision 1 IMU, **THEN CONTACT** Seakeeper Product Support Team at support@seakeeper.com for instructions.
- 4. **IF** NO loose or damaged pins found, **THEN REPLACE** IMU.
- 5. **IF** loose pins/crimps found in connector, **THEN REPAIR** pin(s) **OR REPLACE** wire harness.



Example of a bent pin found on an IMU.



Revision 1 IMU

PRODUCT SEAKEEPER SERIES MODELS

Code 35/251

Step 7 continued

- e. **PERFORM** following at MDB:
- i. **IF** code 251 alarm returns,
THEN:

1. **INSPECT** MDB connector for loose pins or crimps by pulling on wires.



2. **INSPECT** MDB pins for damaged or bent pins.



3. **IF** MDB harness connector pin(s) loose,
THEN REPAIR MDB harness connector **OR REPLACE** wire harness.
4. **IF** MDB pins irreparable **OR** UNSATISFACTORY,
THEN REPLACE MDB.

SEAKEEPER TROUBLESHOOTING GUIDE - 106



PRODUCT SEAKEEPER SERIES MODELS

Code 35 / 251

8. **IF** checks of Steps 6 **OR** 7 are SATISFACTORY **AND** NO spare display was available, **THEN REPLACE** display.
9. **RESTORE** all power to Seakeeper.
10. **IF** alarm persists,
THEN:
 - a. **COMPILE** all data recorded and photo of information screen.
 - b. **SUBMIT** summary of all steps taken and any photo(s) to Seakeeper Product Support Team at support@seakeeper.com for review.

******* END *******

PRODUCT SEAKEEPER SERIES MODELS

CODE 36

To troubleshoot and repair the cause of the “MOTOR FAULT” alarm (Code 36).

BACKGROUND

Code 36 is triggered when the flywheel motor spins faster than a programmed limit in the Seakeeper drive software. The Code 36 alarm will clear once the flywheel motor is powered and running at a speed less than the programmed limit in drive software.

Basic troubleshooting can eliminate some likely causes: electrical connections in the MDB and the GCM harness connection. Replacement of the MDB may be necessary to clear the alarm.

Megohm testing is performed in this guide to determine the condition of the insulation and potting of the motor drive cable and flywheel motor. Because megohmmeters vary in quality and accuracy, the guide uses a time-resistance test that eliminates some of these variables. A meter that can provide a continuous test voltage for 60 seconds is required.

REFERENCES

[SWI-093 - Molex Connector Work Instruction](#)

[SWI-124 - Seakeeper Motor Lead Testing](#)

PRECAUTIONS

See [PRECAUTIONS](#) of Introduction section.

PROCEDURE**SECTION 1: INITIAL CHECKS**

1. **PHOTOGRAPH** Information screen of display/MFD app (showing software versions).
2. **SUBMIT** photo to Seakeeper at support@seakeeper.com for evaluation.
3. **WHEN** told by Seakeeper to proceed in troubleshooting,
THEN CONTINUE in this procedure.

**WARNING!**

PERSONNEL SHOCK HAZARD EXISTS when working on live circuitry.
Seakeeper may start remotely.

4. **ENSURE** flywheel at zero RPM at display or MFD app.
5. **TURN OFF** low current DC breaker to Seakeeper.
6. At MDB, **VERIFY** harness connector is fully inserted into MDB per photos.
7. **IF** connector not seated fully,
THEN FULLY SEAT connector into MDB.
8. At GCM, **VERIFY** 70-pin connector is fully seated.
9. **IF** connector not seated fully,
THEN FULLY SEAT connector into MDB.
10. **INSPECT** wire harness for any damage near MDB.
 - a. **IF** damage found,
THEN REPLACE wire harness.
 - b. **SPOOL** unit to verify alarm clear.

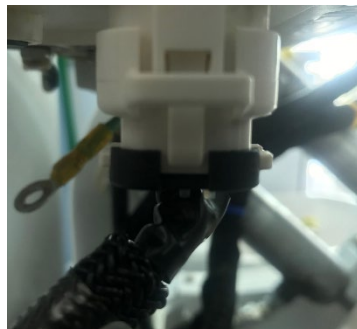

TE Connectivity connector of a Seakeeper 2 or 3 showing locking tab engaged



Molex Connector of an AC-powered Seakeeper shown with white locking tab fully inserted



GCM connector fully inserted and locked

**WARNING!**

SHOCK HAZARD EXISTS WHEN FLYWHEEL ROTATING
OR POWER APPLIED TO SEAKEEPER.

11. **IF** AC-powered Seakeeper model,
THEN PERFORM following:
 - a. **TURN OFF** Seakeeper AC power breaker.
 - b. **REMOVE** MDB cover to expose "MOTOR" lead terminal.
 - i. **INSPECT** crimps at end of each motor cable lead.
 - ii. **LOOSEN** MDB feed-through grommet.
 - iii. **EXAMINE** motor drive cable insulation at grommet.
 - iv. **ENSURE** interior of MDB is free of moisture.

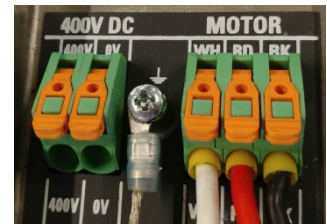

12. **IF** DC-powered Seakeeper,
THEN INSPECT motor drive contacts at MDB.

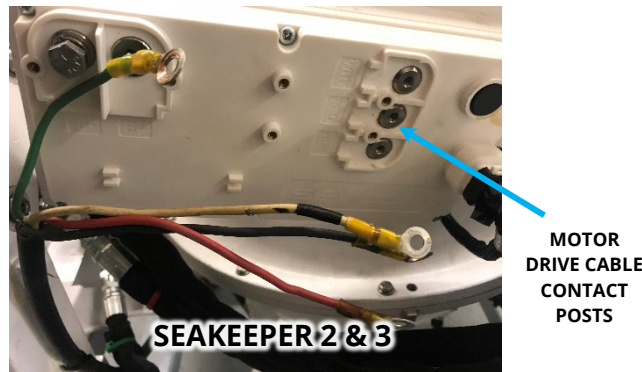

- a. **TURN OFF** high current DC power breaker for Seakeeper.
 - b. **REMOVE** cover at motor drive cable contact posts.
 - c. **INSPECT** for severe corrosion at contacts or damage to cables.
13. For AC and DC-powered models, **DISCONNECT AND ELECTRICALLY ISOLATE** motor drive cable leads.
 14. **GO TO** [Section 2](#) for AC models.
 15. **GO TO** [Section 3](#) for DC models.

SECTION 2: AC-POWERED MODELS

1. **PERFORM** testing of motor leads per [SWI-124 - Seakeeper Motor Lead Testing](#).
2. **RECORD** results of motor lead testing in service report form.
3. **IF:**
 - motor drive cable has any phase-to-phase resistance greater than 2.0Ω ,
 - any phase-to-phase resistance significantly different from other two, **OR**
 - unsatisfactory results from megohm tests,

THEN CONTACT Seakeeper Product Support Team at support@seakeeper.com with all data recorded and photos of any damage to motor power cable found.

4. **RE-ATTACH** all motor cable leads to their respective terminal.
5. **TORQUE** MDB cover screws to **19 in-lbs (2.2 Nm)** to minimize moisture intrusion into MDB.
6. **TURN ON** all Seakeeper power breakers.
7. **IF** issue NOT found,
THEN CONTINUE to [Section 4](#).



SECTION 3: DC-POWERED MODELS

1. **PERFORM** testing of motor leads per [SWI-124 - Seakeeper Motor Lead Testing](#).
2. **RECORD** results of motor lead testing in service report form.

3. **IF:**
 - motor drive cable has any phase-to-phase resistance greater than 2.0Ω ,
 - any phase-to-phase resistance significantly different from other two, **OR**
 - unsatisfactory megohm results,

THEN CONTACT Seakeeper Product Support Team at support@seakeeper.com with all data recorded and any photos of damaged motor power cable.

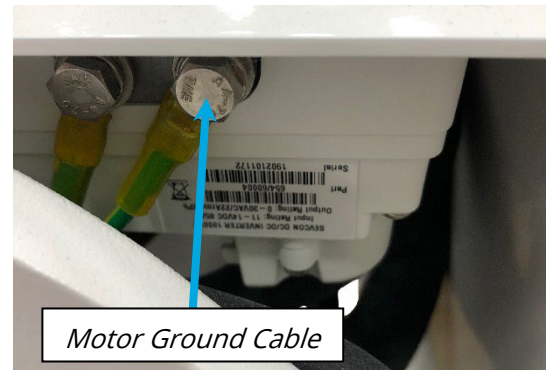

4. **RE-ATTACH** all motor cable leads to their respective terminal, if not already done.
5. **ENSURE** all terminals torqued per [Torque Specifications](#) section.
6. **INSTALL** cover at motor drive cable contact posts **AND** High DC current input terminals.
7. **TURN ON** all Seakeeper power breakers.
8. **IF** issue not found,
THEN CONTINUE to [Section 4](#).

SECTION 4: COMPLETION OF TROUBLESHOOTING

1. **IF** previous steps have not discovered cause of alarm, **THEN REPLACE** MDB.
2. **SPOOL** unit to verify alarm clear.
3. **IF** alarm persists, **THEN:**
 - a. **RECORD** video of display maintenance screen (showing RPM and Current draw) while trying to spool up Seakeeper if possible.

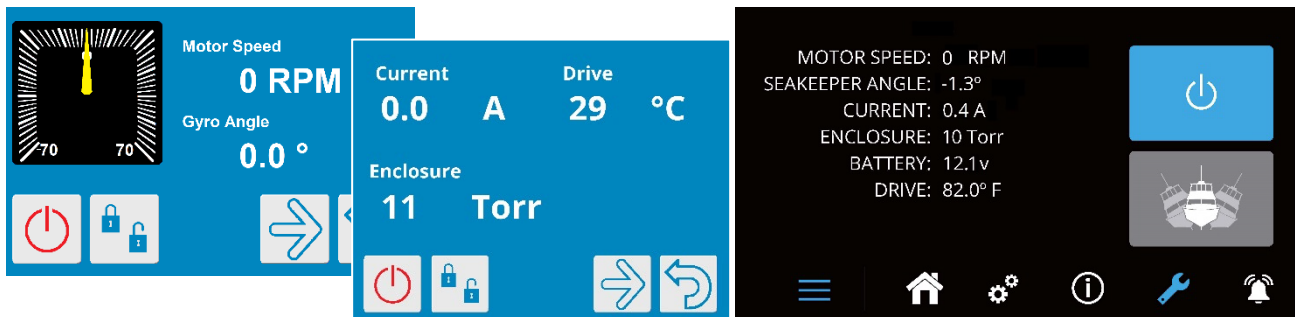

- b. **COMPILE** all data taken and any photos of damage and display information screen.
- c. **SUBMIT** data and recordings to Seakeeper Product Support Team at support@seakeeper.com for review.

******* END *******

PRODUCT SEAKEEPER SERIES MODELS

CODE 40/41/156

To troubleshoot and repair the cause of the

- “DC INPUT VOLTAGE HIGH” alarm (Code 40)
- “DC INPUT VOLTAGE LOW” alarm (Code 41)
- “DRIVE VOLTAGE” warning (Code 156)

BACKGROUND

Continued operation with any of these codes may damage equipment or cause injury. Power to the Seakeeper must be cycled to reset Codes 40 or 41.

Codes 40 and 41 are developed by the GCM when low current DC input voltage varies from a reasonable range for the design voltage; on 24VDC systems (Seakeeper 9/7HD and above), code 40 will be produced when the voltage rises above 32VDC. Code 41 is created when voltage drops below 18VDC (22VDC on Seakeeper 9 & 18 with current GCM software). For 12VDC systems (Seakeeper 6 and below), code 40 alarms at 15VDC and code 41 alarms at 10VDC.

Code 40 or 41 will be able to be reset when voltages are between 18-32VDC (22-32VDC for Seakeeper 9 and 18) for 24VDC systems and between 10-15VDC for 12VDC systems. If they are quickly reset at the helm after alarming, the cause may have been a DC load starting/stopping to create a spike in the vessel's DC system.

Code 156 is triggered by the motor drive when it senses low voltage on the harness +VDC pin. The drive sends a code to the GCM, which triggers the code.

In the event of a low voltage event (Code 41 or 156), additional alarms may appear on the display as voltage continues to drop. On both 12 and 24VDC systems, a Code 43 (Power Relay Fault) may be seen as voltage continues to decline. Additionally, Code 8 (Coolant Pump Fault) may be seen. Eventually, the voltage can drop to the point where the display goes dark (around 8VDC on all models).

Troubleshooting will examine the low current DC input to the Seakeeper and then examine components on the Seakeeper that, when experiencing a fault, can produce this alarm.

REFERENCES

[TB-90603-1 - DC SEAKEEPER ELECTRICAL INTEGRATION DIAGRAMS](#)

PRECAUTIONS

see [PRECAUTIONS](#) section of Introduction.

PROCEDURE

1. **VERIFY** DC input voltage at Seakeeper within proper voltage range of **22-32VDC** for Seakeeper 9/7HD (9-201-2839 or after) through 18/16 (18/16-194-0001 or after), **18-32VDC** for Seakeeper 9 (earlier than 9-2839), 16 (EM), 26, 35, and 40 **OR 11-15VDC** for Seakeeper 6 and below.
 - a. **IF** voltage BELOW required voltage range,
THEN CHECK vessel's electrical supply:
 - i. **RECORD** battery bank voltage across terminals. _____ **VDC**
 - ii. On positive supply, **VERIFY** fuse/breaker NOT blown/tripped.
 - iii. **VERIFY** leads of breaker contacts/fuse contacts are seated securely.
 - iv. **IF** DC power supply fused,
THEN VERIFY fuse is seated correctly.
 - v. **VERIFY** protection is of proper rating (See [ATTACHMENT 1](#) for correct voltages).
 - vi. **CHECK** battery terminals secured tightly.
 - vii. On negative terminal block, **VERIFY** connection is free of corrosion.
 - viii. **IF** terminal is double-stacked with other loads' cables,
THEN ENSURE largest ampacity cable is closest to base of terminal stud **AND** no more than four terminals stacked on post.
 - b. **IF** voltage ABOVE required voltage range,
THEN CHECK vessel's electrical supply:
 - i. **IF** vessel powered by outboard engines,
THEN PERFORM sea trial at high engine RPMs.
 1. With multimeter, **CHECK** voltage from engine alternator(s).
 2. **IF** battery charge is above **15VDC**,
THEN INVESTIGATE charge relay(s) or alternator voltage regulation.
 - ii. **CHECK** battery charger output voltage.
 - c. **MONITOR** system voltage as other high-current vessel loads are started and stopped.
 - i. **IF** a particular load creates a voltage spike (to produce Code 5, 40 or 41),
THEN INVESTIGATE OR MITIGATE voltage spike cause. [Consider placing Seakeeper or load on another battery bank]

2. **IF** Seakeeper is AC-powered (Seakeeper 5/6 or above), **THEN:**
 - a. **TURN OFF** DC power breaker.
 - b. **CHECK** nameplate data of main power relay for correct voltage rating.

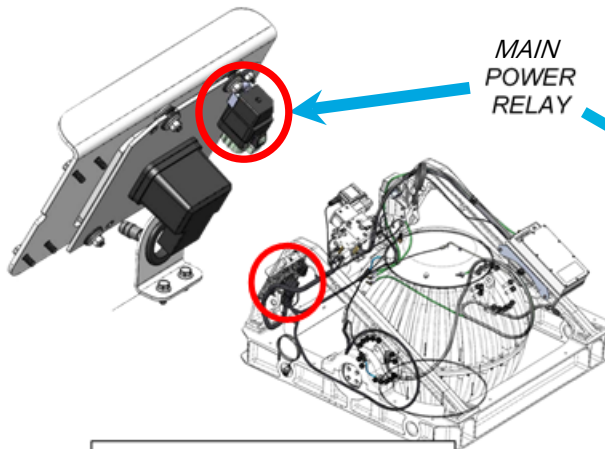

Illustration showing the location of the power relay on a Seakeeper 26 model

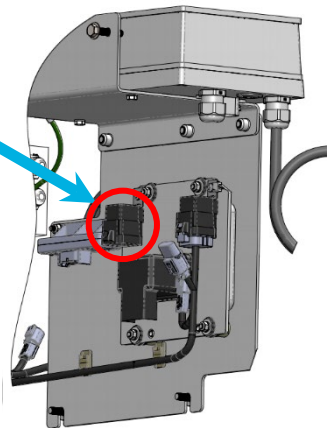
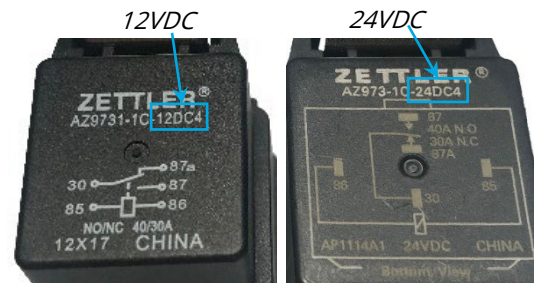

Illustration showing the location of the power relay on a Seakeeper 9 model

- c. **VERIFY** stated voltage matches voltage rating of Seakeeper model per [ATTACHMENT 1](#).
 - i. **IF** data marked on relay does NOT match voltage rating for Seakeeper, **THEN REPLACE** main power relay.
 - ii. **CHECK** Code 40/41 alarm clear.



**WARNING!**

PERSONNEL SHOCK HAZARD EXISTS when working on live circuitry.

3. **CHECK** wiring harness for short to ground as follows:

- a. **DISCONNECT** low current DC power from Seakeeper using Deutsch connector, as shown to right.
- b. **REFERENCE** [ATTACHMENT 2](#) for access instructions to components for various models for following steps.
- c. **DISCONNECT** Glycol Pump from wire harness.
- d. **DISCONNECT** GCM from wire harness.
- e. **DISCONNECT** IMU from wire harness.
- f. **IF** 3.5" or 5" display used, **THEN DISCONNECT** display from Seakeeper.
- g. With multimeter in resistance mode, **CHECK** for SHORT between pin **1** and pin **2** of low current DC input socket of harness.
- h. **IF SHORT OR** intermittent SHORT found, **THEN REPLACE** wire harness.

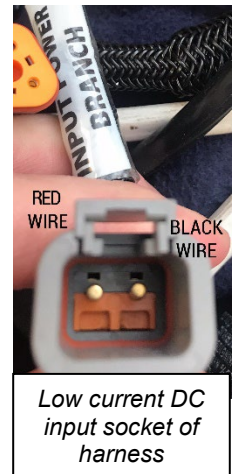

4. **CHECK** glycol pump wiring for short as follows:

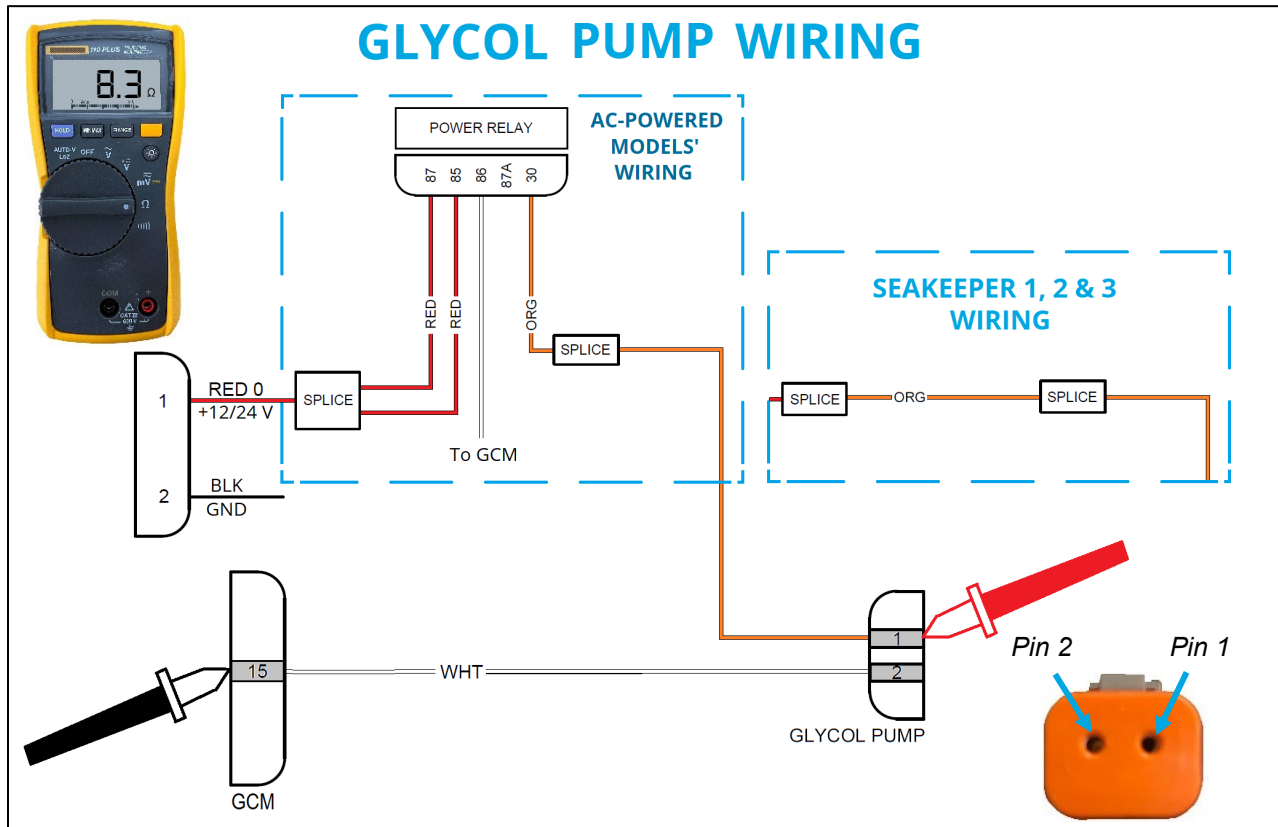

- a. **TEST** for SHORT between harness connector Pin 1 and GCM Pin 15 (GCM Pin 4 for Seakeeper 6/5 and glycol pump 2 on Seakeeper 35 & 40).
- b. **IF** SHORT or intermittent SHORT found, **THEN REPLACE** wire harness.



5. **CHECK** Brake Manifold Solenoid Valves for short as follows:

- Pin 1 = 12/24v+ from Line 71 (*Orange wire*)
- Pin 2 = GCM pin 5 for Solenoid 1
GCM pin 9 for Solenoid 2
GCM pin 20 for Solenoid 3
GCM pin 23 for Solenoid 4 (*White wire*)



Deutsch connector to brake solenoid from wire harness

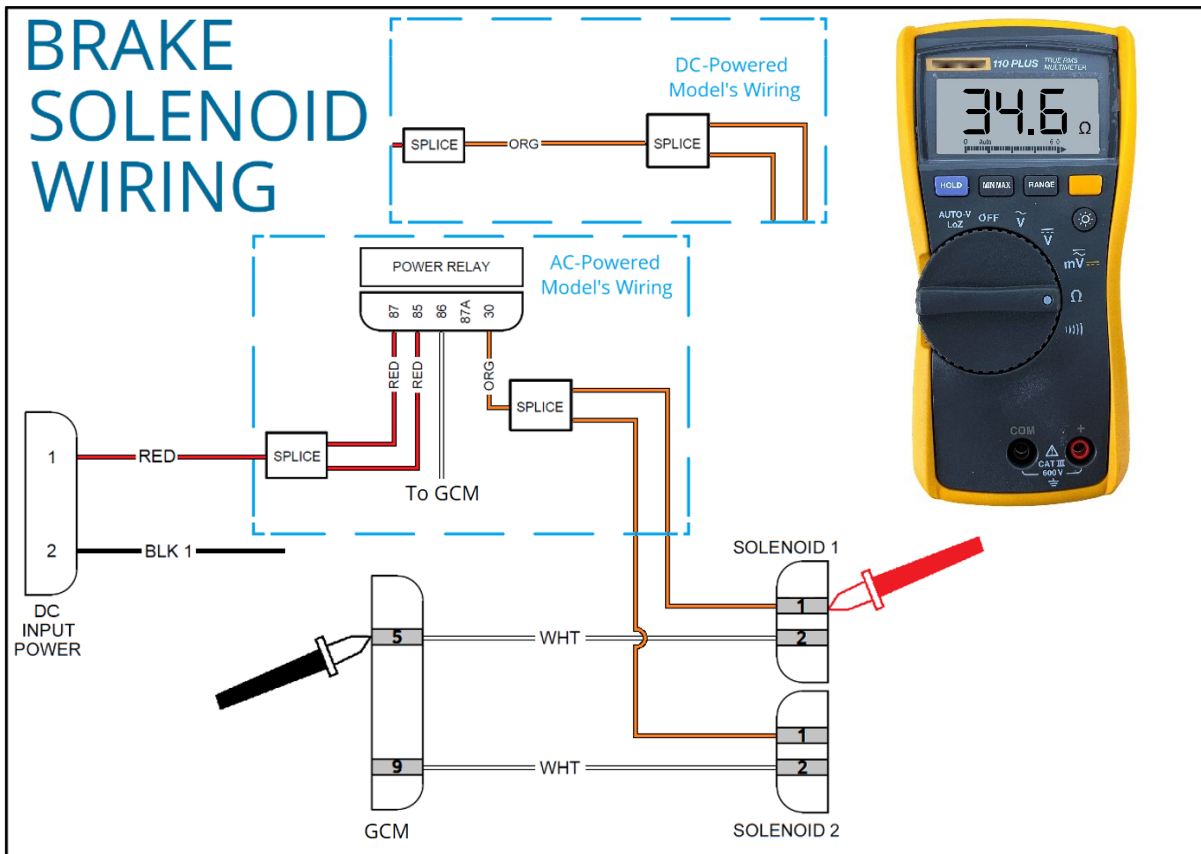

- a. **DISCONNECT** Solenoid Valve 1 from wire harness.

Step 5 continued

- b. **TEST** for SHORT between solenoid harness connector pin **1** and GCM pin **5**.



*Testing continuity
between pin 1 and GCM
pin 5 (for Solenoid 1)*



- c. **DISCONNECT** Solenoid Valve 2 from wire harness.
- d. **TEST** for SHORT between solenoid harness connector pin **1** and GCM pin **9**.
- e. **DISCONNECT** Solenoid Valve 3 from harness, if equipped.
- f. **TEST** for SHORT between solenoid harness connector pin **1** and GCM pin **20**.
- g. **DISCONNECT** Solenoid Valve 4 from harness, if equipped.
- h. **TEST** for SHORT between solenoid harness connector pin **1** and GCM pin **23**.
- i. **IF SHORT OR** intermittent SHORT found in any manifold solenoid wiring,
THEN REPLACE wire harness.
- j. **RECONNECT** all solenoids to their harness connectors.



6. **CHECK** Brake (Proportional) Valve for **SHORT** as follows:

Pin 1 = 12/24v+ from Line 71 (*Orange wire*)
 Pin 2 = GCM pin 11 (*White wire*)

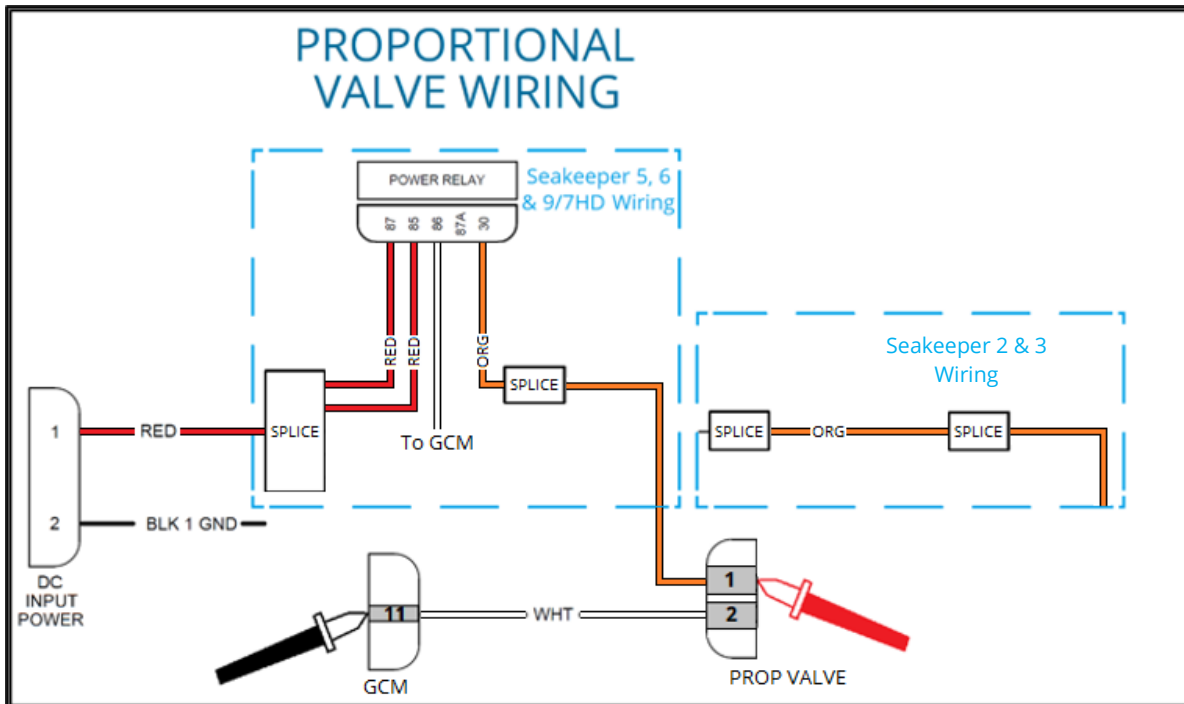
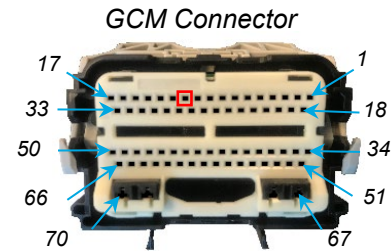
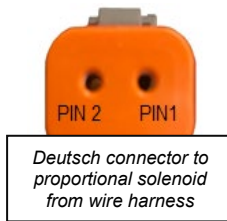

- a. **IF** Seakeeper 9/7HD or below, **THEN PERFORM** following:
 - i. **DISCONNECT** Brake (Proportional) Valve from wire harness.
 - ii. **TEST** for **SHORT** between harness connector pin **1** and GCM pin **11**.
 - iii. **IF SHORT OR** intermittent **SHORT** found, **THEN REPLACE** wire harness.

Step 6 continued

- b. **IF** Seakeeper 16/12HD (S/N: 16-0001 through 16-193-0916),

THEN PERFORM following:

HIRSCHMANN GDMZ RB 29 0 316 0

or GDM 2009 J BLACK

Pin 1 = Line 71 +24VDC (*orange wire*)

Pin 2 = GCM pin 11 (*white wire*)

Pin 3 = NOT USED

GND = NOT USED

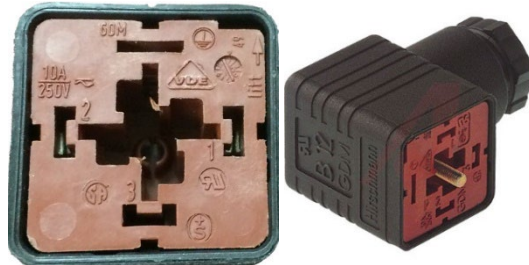

- i. **DISCONNECT** Proportional Valve from wire harness.

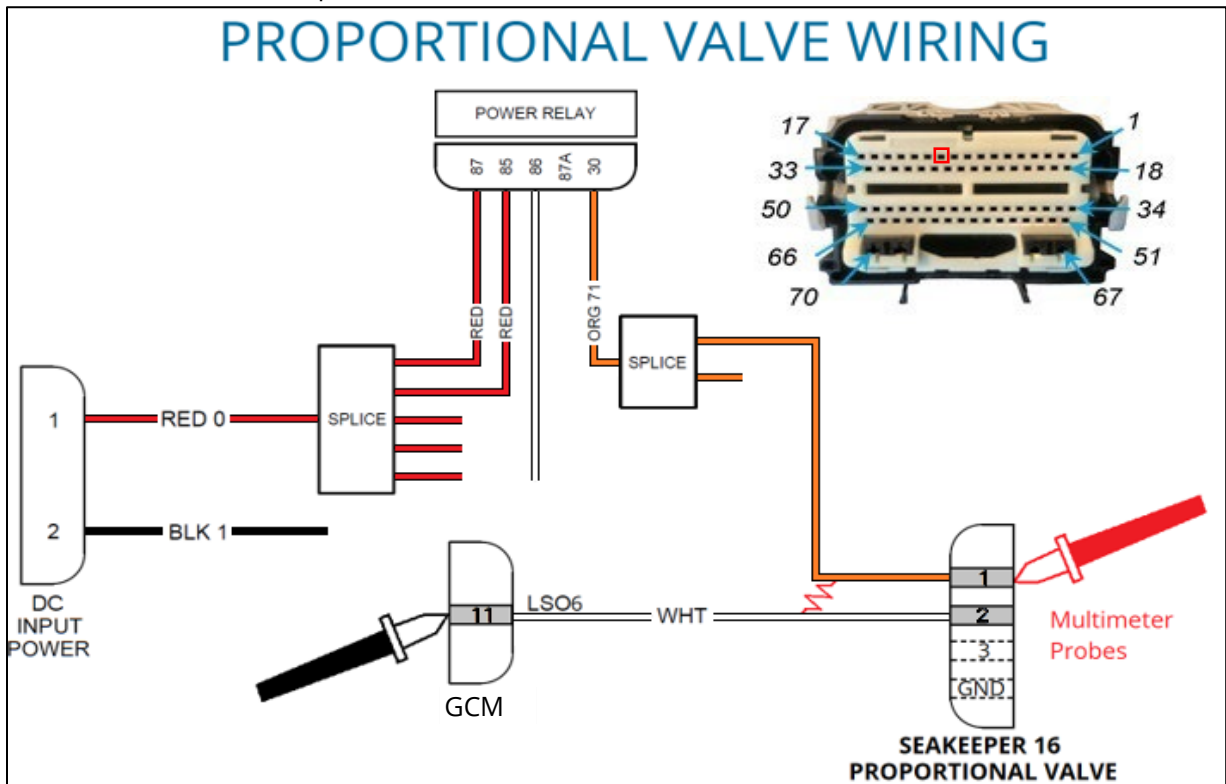

- ii. **TEST** for SHORT between proportional harness connector pin **1** and GCM pin **11**.
- iii. **IF** SHORT **OR** intermittent SHORT found, **THEN REPLACE** wire harness.

Step 6 continued

- c. **IF** Seakeeper 26/20HD, 35/30HD, or 40, **THEN PERFORM** following:

Pin A: 71 (+24VDC) (Orange Wire)
 Pin B: Ground B1 (Black Wire)
 Pin C: Ground B1 (Black Wire)
 Pin D: 72 SVCMD to IMU Pin 7 (White Wire)
 Pin E: Ground B1 (Black Wire)
 Pin F: Not Used
 Pin G (Center): Not Used
Pins B, C & E are connected and should have low/no resistance between them

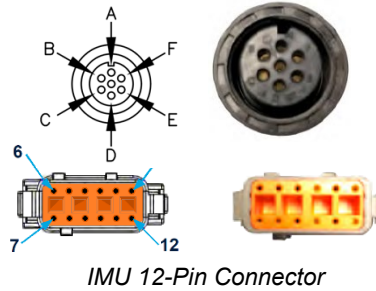

- i. **DISCONNECT** Proportional Valve from harness.
- ii. **TEST** for SHORT between harness connector pin **A** and IMU pin **7**.
- iii. **TEST** for SHORT between harness connector pin **A** and harness connector pin **B**.

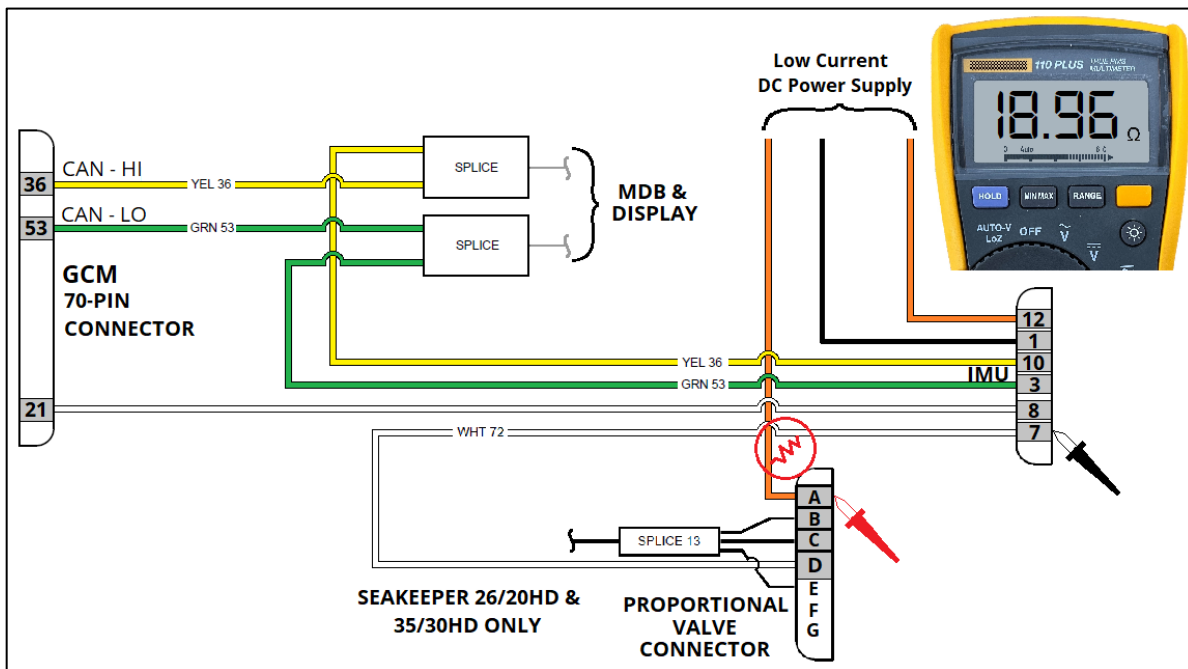

- iv. **IF SHORT OR** intermittent SHORT found, **THEN REPLACE** wire harness.
- d. **RECONNECT** brake proportional connector.

NOTE:

Even if model is NOT equipped with a heater option, the wiring is still susceptible to shorts.

7. **IF** Seakeeper 26/20HD, 35/30HD, or 40, **THEN CHECK** for short in heater wiring as follows:

a. **DISCONNECT** heater from wire harness **OR REMOVE** connector plug.

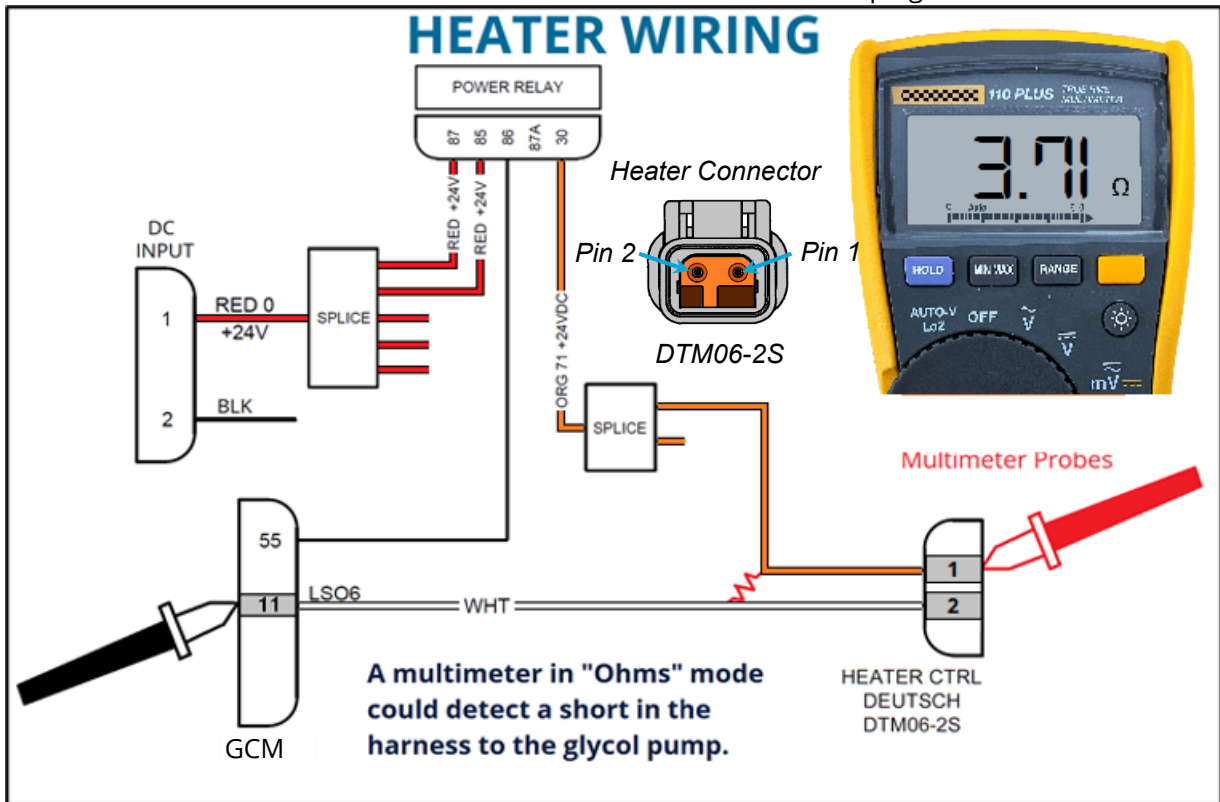

- b. At harness connector, **TEST** resistance between **TEST** for SHORT between heater harness connector pin **1** and GCM pin **11**.
- c. **IF SHORT OR** intermittent SHORT found, **THEN REPLACE** wire harness.
- d. **RECONNECT** heater or connector plug to wire harness.

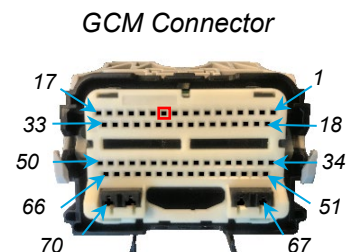

SEAKEEPER TROUBLESHOOTING GUIDE - 106



PRODUCT SEAKEEPER SERIES MODELS

Code 40/41/156

8. **IF** alarm persists,
THEN:
 - a. **COMPILE** troubleshooting test results and a photo of information screen.
 - b. **PHOTOGRAPH** any physical damage found.
 - c. **SUBMIT** data and photos collected to Seakeeper Product Support Team at support@seakeeper.com.

******* END *******

ATTACHMENT 1: POWER REQUIREMENTS

POWER REQUIREMENTS				
MODEL	HI CURRENT INPUT TO MDB	BREAKER/ FUSE RATING	DC INPUT	BREAKER/ FUSE RATING
Seakeeper 2 & 3	12VDC	100 A @ 12VDC	12VDC	15 A
Seakeeper 5/3DC 5/3DC-0001 through 5/3DC-1049	110/230VAC	30 A @ 110VAC 25A @ 230VAC	12VDC	15 A
Seakeeper 5 & 6	110/230VAC	30 A @ 110VAC 25 A @ 230VAC	12VDC	15 A**
Seakeeper 9/7HD	230VAC	20 A	24VDC	10 A**
Seakeeper 16/12HD Up to 16/12HD-193- 0912	230VAC	20 A	24VDC	10 A
Seakeeper 18/16/12HD*	230VAC	30 A	24VDC	10 A**
Seakeeper 26/20HD	230VAC	20 A	24VDC	10 A
Seakeeper 35/30HD	230VAC	30 A	24VDC	15 A
Seakeeper 40	230VAC	30 A	24VDC	15 A
* Seakeeper 16/12HD after 16/12HD-194-0001				
** Two relays exist on harness: 1 power & 1 SW Pump on models built after 2019, 3 ^d quarter				

PRODUCT SEAKEEPER SERIES MODELS

Code 40/41

Page 1 of 2

ATTACHMENT 2: ACCESSING MDB IN SEAKEEPER 2 & 3

1. For Seakeeper 2 and 3 access to MDB:
 - a. **REMOVE** hex-head screws of rear panel, shown below.

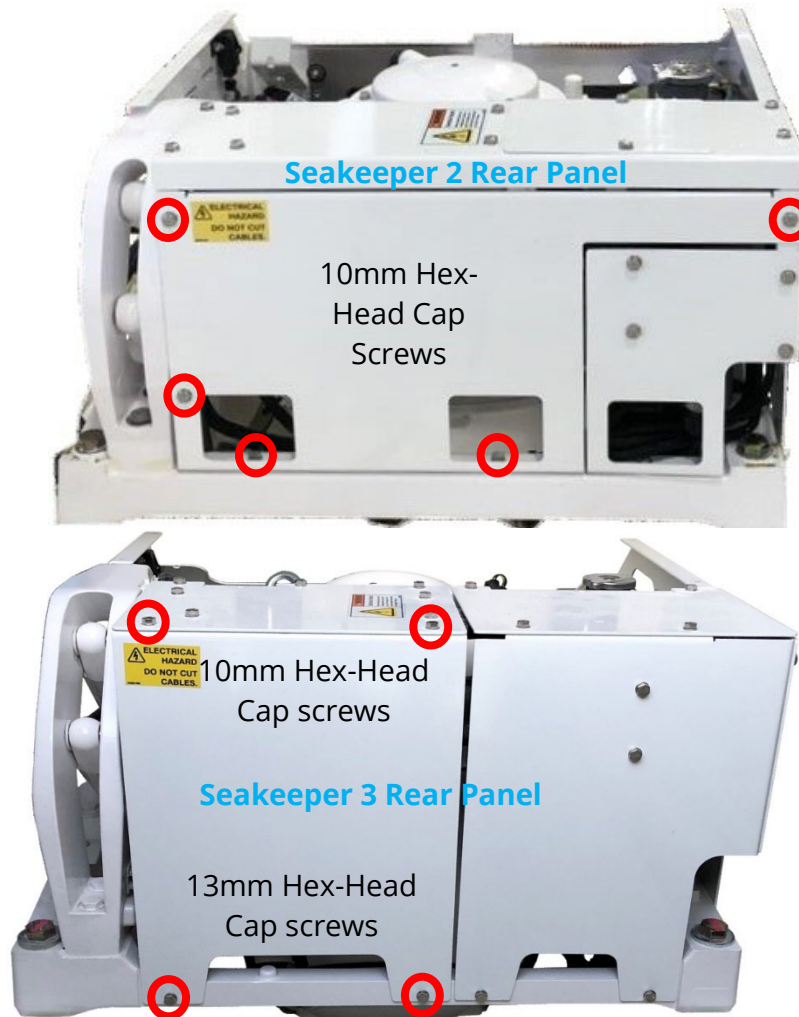

- b. **TILT** top of rear panel out.
2. For access to Seakeeper 2 and 3 GCM, IMU, and glycol pump, **LOCATE** these items attached to front panel.

PRODUCT SEAKEEPER SERIES MODELS

Code 40/41

ATT. 2 continued

Page 1 of 1

3. For Seakeeper 6/5 through 18 access to GCM, IMU, and MDB:

- a. Using a combination of 10 mm and 13 mm sockets, **REMOVE** screws at top of rear panel.
- b. Using 13 mm socket, **LOOSEN** screws at bottom of rear panel.

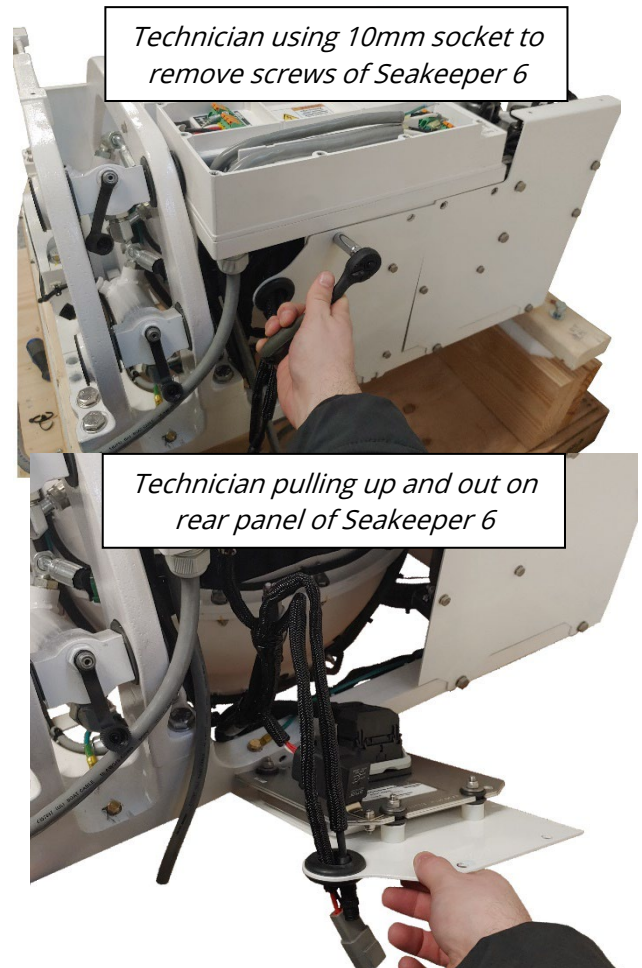

- c. **LIFT UP AND OUT** on top of rear panel.
- d. **DISCONNECT** GCM and IMU, as desired.
- e. **LOCATE** glycol pump attached at front panel on these models.

PRODUCT SEAKEEPER SERIES MODELS

CODE 43/154

To troubleshoot and repair the “POWER RELAY” [Stuck Off] alarm (Code 43) and the “POWER RELAY STUCK ON FAULT” alarm (Code 154).

BACKGROUND

Code 43 is introduced when the voltage supplied to the 12/24VDC system of the electrical sub-system drops below 10/17VDC on AC-powered Seakeeper models. This voltage supplies the glycol pump, the brake solenoids, MDB, and IMU. On larger Seakeeper models, it also powers the heater if installed. This code closes the brake valves to stop precession (because they will de-energize by the nature of the code) and de-energizes the flywheel motor. Because this code has been triggered by low DC input voltage, if accompanied by a Code 41, troubleshoot Code 41 first.

Code 154 is introduced when driver power remains high after de-energizing the Power Relay. However, this is highly unlikely, based on the required conditions. Troubleshoot in the same manner as the relay being “stuck off.”

One common cause of this code is the starting of large DC loads while the Seakeeper is in operation. Another cause is an improper Power Relay (e.g., a 12VDC relay installed in a 24VDC system). A short to ground in wiring can also cause this code.

AC-powered Seakeepers are equipped with a relay that is an electromechanical, single pole, double throw (SPDT) relay. It uses a low-current coil to activate a higher-current switch. The coil has no diode or resistor protection. The Seakeeper 2 and 3 do not have Power Relays installed (DC Seawater Relays are installed on DC models).

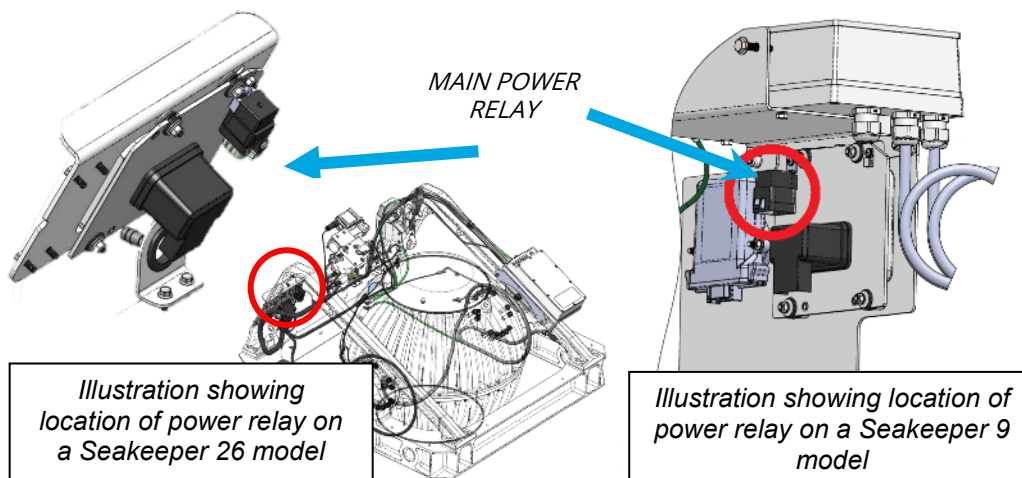
**PRECAUTIONS**

See [PRECAUTIONS](#) of Introduction section.

SEAKEEPER TROUBLESHOOTING GUIDE - 106

PRODUCT SEAKEEPER SERIES MODELS

Code 43/154

PROCEDURE

1. **VERIFY** DC input voltage at Seakeeper is within proper voltage band: 22-32VDC for Seakeeper 9/7HD and above OR 11-15VDC for Seakeeper 6/5.
 - a. **IF** voltage is not within required voltage band,
THEN CHECK vessel's power supply.
 - i. On positive supply, **VERIFY** fuse/breaker is not blown/tripped.
 - ii. **IF** positive is protected by a fuse,
THEN VERIFY fuse is seated properly.
 - iii. **VERIFY** protection is of proper rating (See TABLE 1 for proper voltages).
 - iv. On negative terminal block, **VERIFY** connection is free of corrosion.
 - v. **IF** terminal is double stacked with other loads' cables,
THEN ENSURE largest ampacity cable is closest to base of terminal stud.
 - b. **IF** input voltage found to be within specification,
THEN CONTINUE with this procedure.



*DC input
connector from
vessel's DC
power supply.*

TABLE 1: POWER REQUIREMENTS				
MODEL	HI CURRENT INPUT TO MDB	BREAKER/ FUSE RATING	DC INPUT	BREAKER/ FUSE RATING
Seakeeper 5 (EM) 5-0001 through 5-1049	110/230 VAC	30 A @ 110VAC 25A @ 230VAC	12VDC	15 A
Seakeeper 5 & 6	110/230 VAC	30 A @ 110VAC 25 A @ 230VAC	12VDC	15 A
Seakeeper 9/7HD	230 VAC	20 A	24VDC	10 A
Seakeeper 16/12HD Up to 16/12HD-193-0912	230 VAC	20 A	24VDC	10 A
Seakeeper 18/16/12HD*	230 VAC	30 A	24VDC	10 A**
Seakeeper 26/20HD	230 VAC	20 A	24VDC	10 A
Seakeeper 35/30HD	230 VAC	30 A	24VDC	15 A
Seakeeper 40	230 VAC	30 A	24VDC	15 A

* Seakeeper 16/12HD after 16/12HD-201-0001 ** Two relays exist on harness: 1 power & 1 SW Pump

2. **DISCONNECT** DC power supply.
3. **PERFORM** following checks:
 - a. **VERIFY** power relay nameplate voltage matches voltage rating of Seakeeper model per TABLE 1. Power relay is attached near GCM.
 - b. **IF** data marked on relay does NOT match DC input voltage rating for Seakeeper, **THEN REPLACE** main power relay.
 - c. **TEST** relay as follows:
 - i. **DISCONNECT** power relay from wire harness.
 - ii. With a multimeter **CHECK** for 0.3Ω or less between pin **30** and pin **87A**.

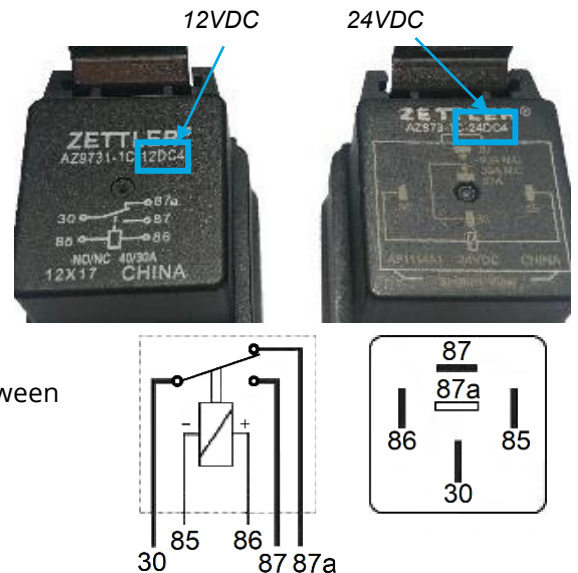

SEAKEEPER TROUBLESHOOTING GUIDE - 106

PRODUCT SEAKEEPER SERIES MODELS

Code 43/154

Step 3.c continued

- iii. With a multimeter **MEASURE** resistance between pin **85** and pin **86**. [**NOTE:** A 12V relay will show 88 ohms, and a 24V relay will show 340 ohms.]
- iv. **IF** resistance in Steps 3.c.ii or 3.c.iii were **UNSATISFACTORY**, **THEN REPLACE** power relay.



- d. **ALIGN** power to Seakeeper.
- e. **CHECK** Code 43 (154) alarm clear.

4. **CHECK** wire harness as follows:

- a. **DISCONNECT** DC power from Seakeeper.
 - i. **INSPECT** connector for loose wires and crimps.

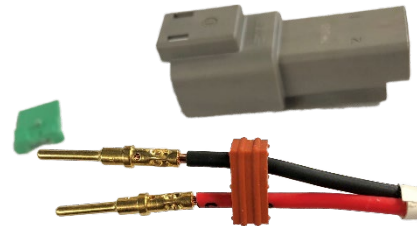

- ii. **REPAIR** any issue found.
- b. **DISCONNECT** following:
 - i. GCM from harness.
 - ii. Display from Seakeeper.
- c. With a multimeter, **CHECK** for short between pin **1** and pin **2** of DC input socket of harness.
- d. **IF** multimeter reads any resistance other than "OL" (Open Loop), **THEN REPLACE** wire harness.
 - i. After replacing harness, **RESTORE** all connections to harness.
 - ii. **RECONNECT** DC power **AND VERIFY** alarm clear.

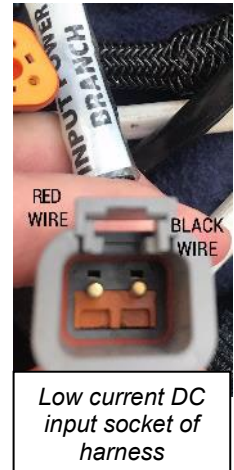

5. **CHECK** glycol pump wiring for a short as follows:
 - a. **DISCONNECT** DC Input connector to Seakeeper.
 - b. **DISCONNECT** glycol pump and GCM from wire harness.

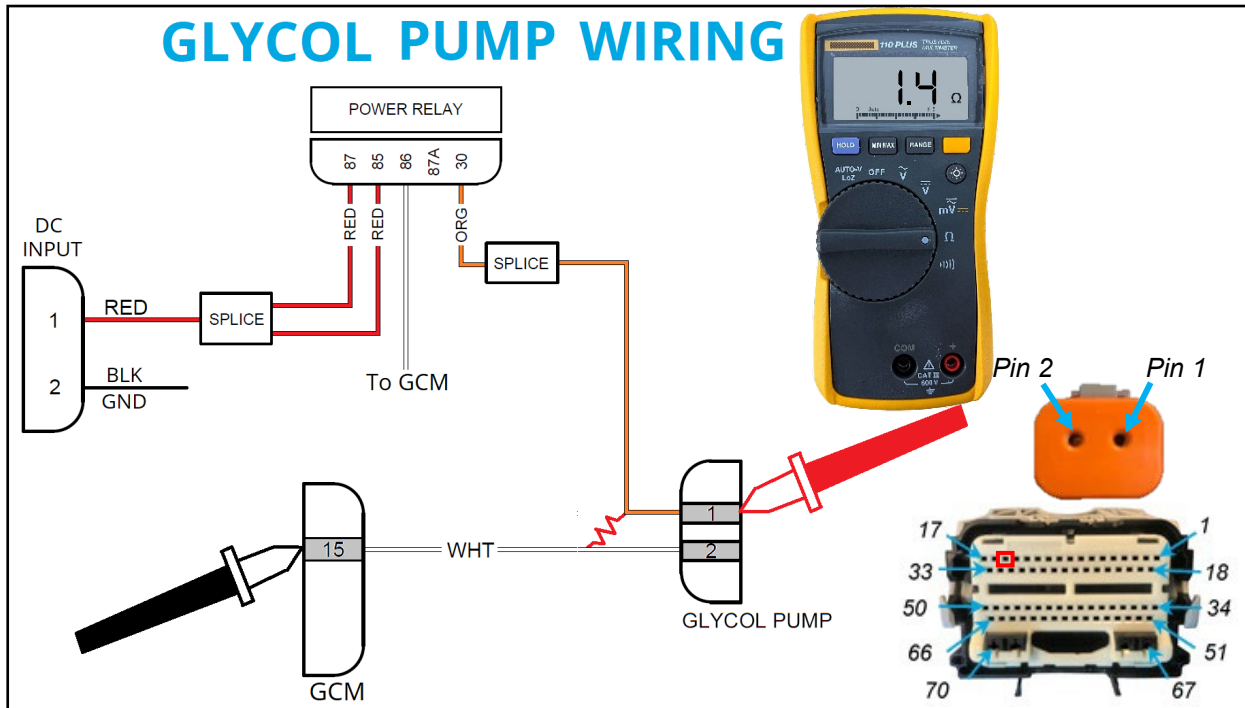

- c. With multimeter, **TEST** resistance between glycol harness connector Pin **1** and GCM Pin **15** (GCM Pin **4** for Seakeeper 6 and glycol pump 2 on Seakeeper 35 & 40).
- d. **IF** resistance in Step 5.c was any resistance other than "OL" (Open Loop), **THEN REPLACE** wire harness.
- e. On male connector from pump, **TEST** for resistance across motor between two male pins.
- f. **IF** resistance across two pins of glycol pump below 1000Ω, **THEN REPLACE** glycol pump.
- g. **IF** alarm not clear, **THEN:**
 - i. **LEAVE** DC Input disconnected.
 - ii. **CONTINUE** this procedure.

6. **CHECK** brake manifold solenoid valves for short as follows:

Resistances are stamped in sides of coils and measured between pins of coil:

Pin 1 = 12/24v+ from Line 71 (*Orange wire*)
 Pin 2 = GCM pin 5 for Solenoid 1
 GCM pin 9 for Solenoid 2
 GCM pin 20 for Solenoid 3
 GCM pin 23 for Solenoid 4 (*White wire*)

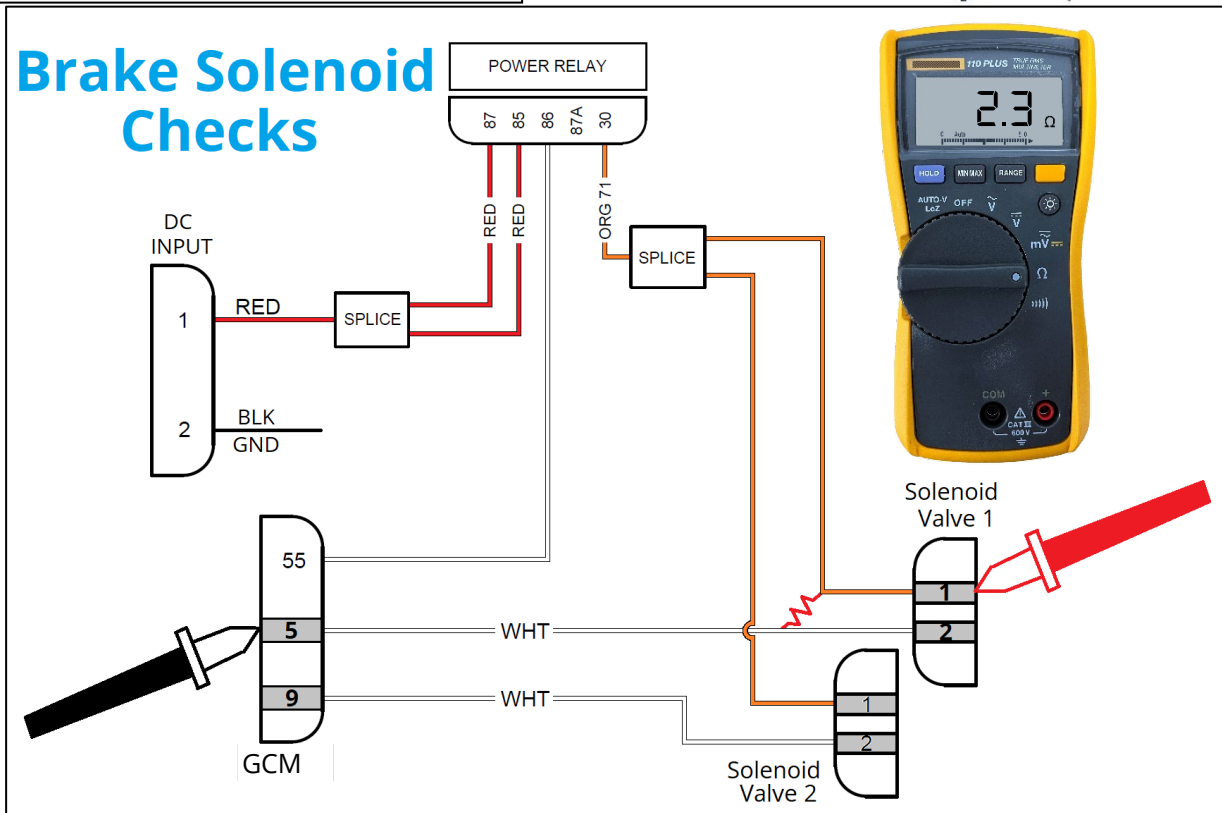
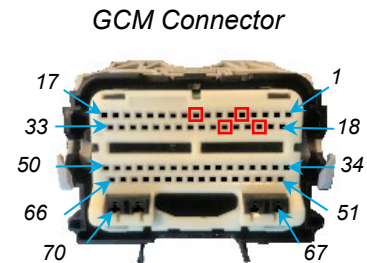
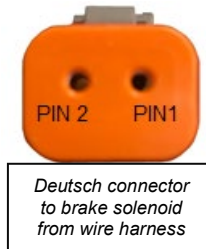

- a. **DISCONNECT** 70-pin GCM connector.
- b. **DISCONNECT** solenoid valve 1 from harness.
 - i. **INSPECT** connectors for loose wires and crimps.

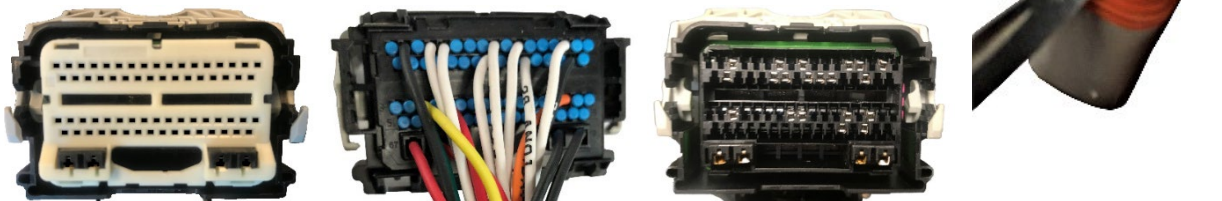

Step 6.b continued

- ii. **CHECK** for short between harness connector pin **1** and GCM pin **5**.



*Testing resistance
between pin 1 and GCM
pin 5 (for solenoid 1)*

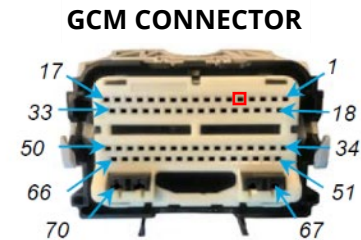

- c. **DISCONNECT** solenoid valve 2 from harness.
- INSPECT** solenoid connector for loose wires and crimps.
 - CHECK** for short between harness connector pin **1** and GCM pin **9**.
- d. **DISCONNECT** solenoid valve 3 from harness, if equipped.
- INSPECT** solenoid connector for loose wires and crimps.
 - CHECK** for short between harness connector pin **1** and GCM pin **20**.
- e. **DISCONNECT** Solenoid Valve 4 from harness, if equipped.
- INSPECT** solenoid connector for loose wires and crimps.
 - CHECK** for short between harness connector pin **1** and GCM pin **23**.
- f. **IF** any resistances above are less than "OL" (Open Loop), **THEN REPLACE** wire harness.
- g. **IF** any loose wires or crimps found, **THEN REPAIR** connector(s).
- h. **RECONNECT** all solenoids to their harness connectors leaving GCM disconnected.

7. **CHECK** Proportional Valve for a short as follows:
- a. **IF** a Seakeeper 5/6/9/7HD/18/16 (S/N: 16-194-0001 or later), **THEN PERFORM** following:

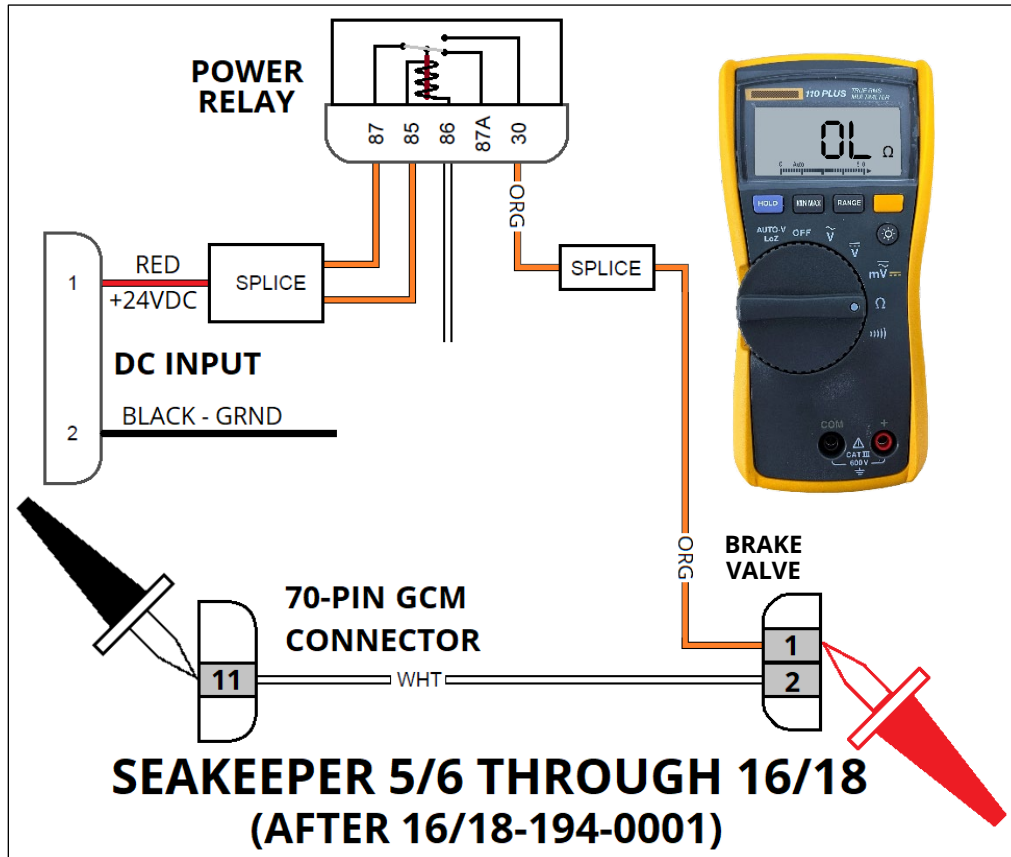

- i. **DISCONNECT** proportional (brake) valve from harness.
- ii. **INSPECT** proportional valve connector for loose wires and crimps.
- iii. **CHECK** for short between harness connector pin 1 and GCM pin 11.
- iv. **IF** resistance found is less than "OL" (Open Loop), **THEN REPLACE** wire harness.

Step 7.a continued

- v. **IF** loose wires or crimps found, **THEN REPAIR** connector.
- vi. **RECONNECT** proportional (brake) valve to harness connector leaving GCM disconnected.
- b. **IF** Seakeeper 16/12HD (S/N 16-0001 through 16-193-0912), **THEN PERFORM** following:

HIRSCHMANN GDMZ RB 29 0 316 0
or GDM 2009 J BLACK

Pin 1 = Line 71 +24VDC (*orange wire*)
Pin 2 = GCM pin 11 (*white wire*)
Pin 3 = NOT USED
GND = NOT USED

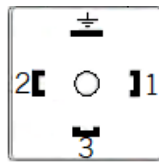

- i. **DISCONNECT** Proportional Valve from harness.
- ii. **INSPECT** connector for loose wires and crimps.

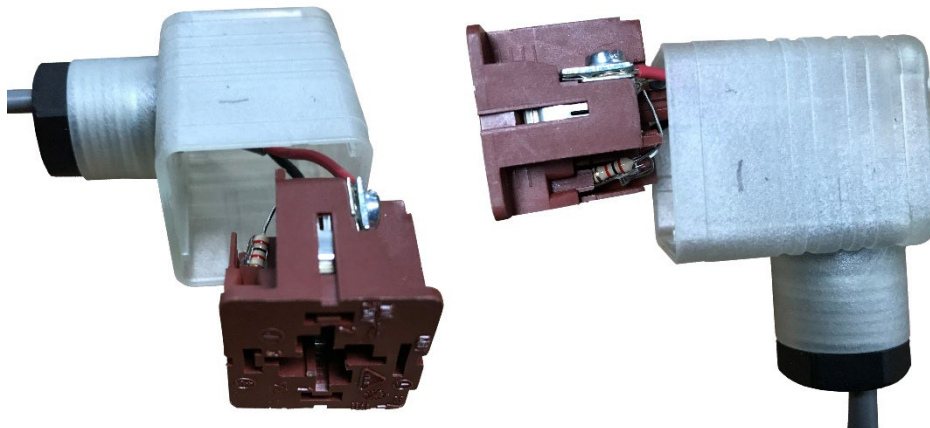

Step 7.b continued

- iii. **CHECK** for short between harness connector pin **1** and GCM pin **11**.

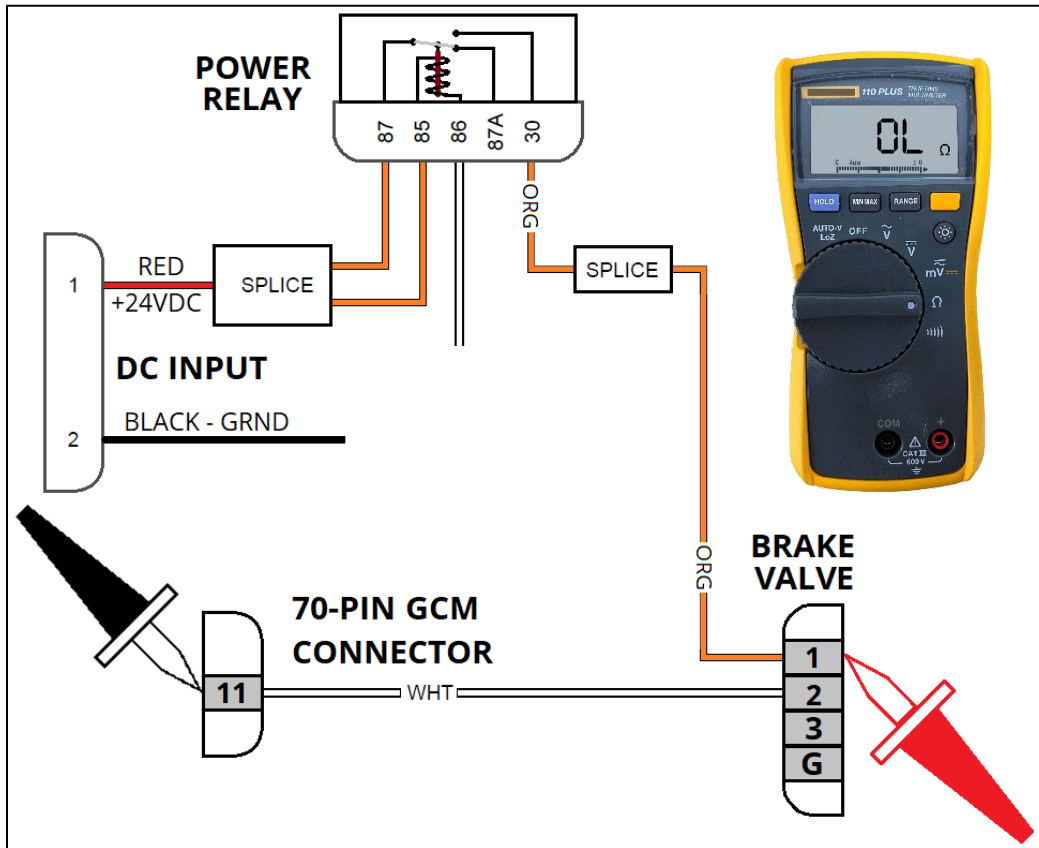

- iv. **IF** resistance found is less than "OL" (Open Loop), **THEN REPLACE** wire harness.
- v. **RECONNECT** Proportional Valve to harness connector leaving GCM disconnected.

Step 7 continued

- c. **IF** Seakeeper 26/20HD, 35/30HD, or 40, **THEN PERFORM** following:

Pin A: 71 (+24VDC) (Orange Wire)
 Pin B: Ground B1 (Black Wire)
 Pin C: Ground B1 (Black Wire)
 Pin D: 72 SVCMD to IMU Pin 7 (White Wire)
 Pin E: Ground B1 (Black Wire)
 Pin F: Not Used
 Pin G (Center): Not Used
Pins B, C & E are connected and should have low/no resistance between them

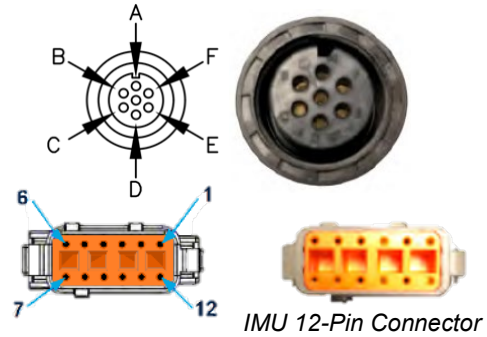

- i. **DISCONNECT** proportional valve **AND** IMU from harness.
- ii. **INSPECT** connectors for loose wires and crimps.
- iii. **TEST** for short between harness connector pin **A** and IMU pin **7**.

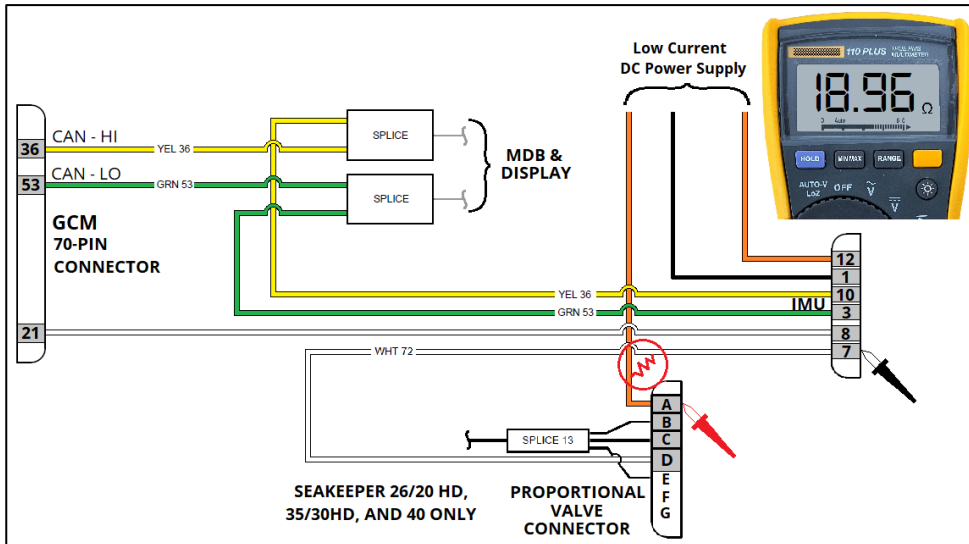
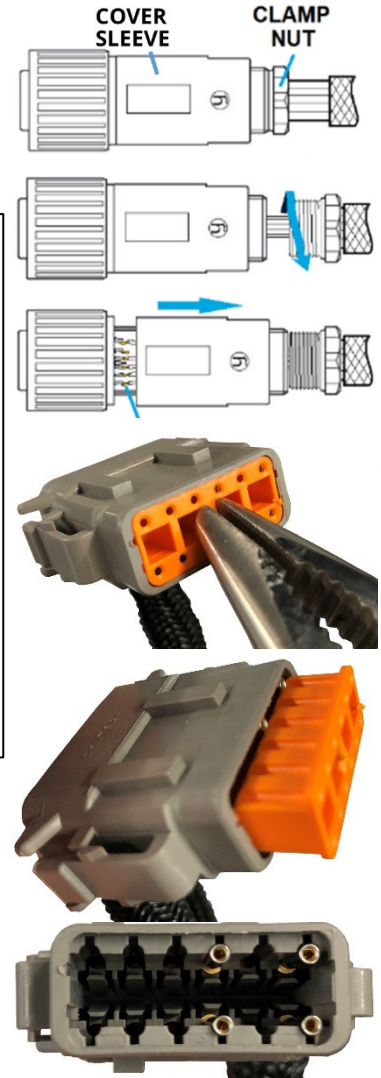

- iv. **TEST** for short between harness connector pin **A** and harness connector pin **B**.
- v. **IF** resistance found is less than "OL" (Open loop), **THEN REPLACE** wire harness.

Step 7.c continued

- vi. **IF** loose wires or crimps found, **THEN REPAIR** connector(s).
- vii. **RECONNECT** Proportional Valve to its harness connector leaving GCM disconnected.

NOTE:

Even if model NOT equipped with heater, wiring is susceptible to shorting.

8. **IF** Seakeeper 26/20HD, 35/30HD, or 40, **THEN CHECK** for a short in heater cable as follows:

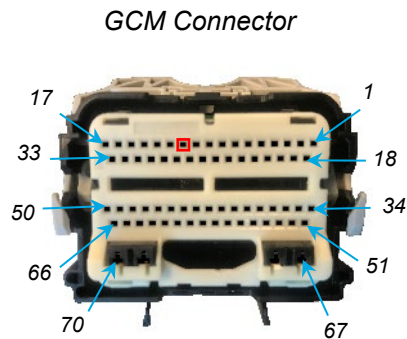
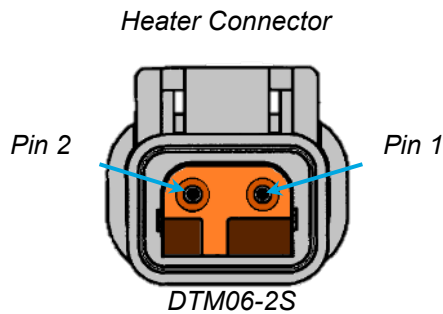

- a. **DISCONNECT** heater **OR** connector plug from wire harness.
- b. **INSPECT** connector for loose wires and crimps.
- c. **IF** loose wire or crimp found, **THEN REPAIR** connector.

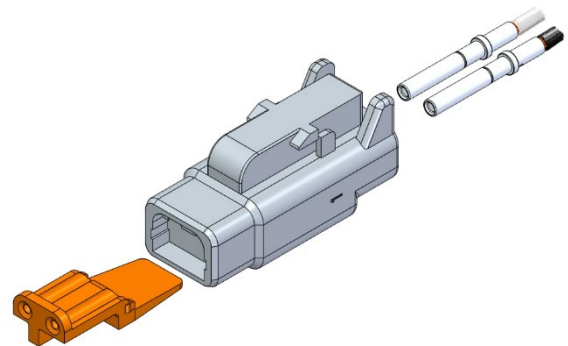

Step 8 continued

- d. **TEST** for short between pin **1** and GCM pin **11**.

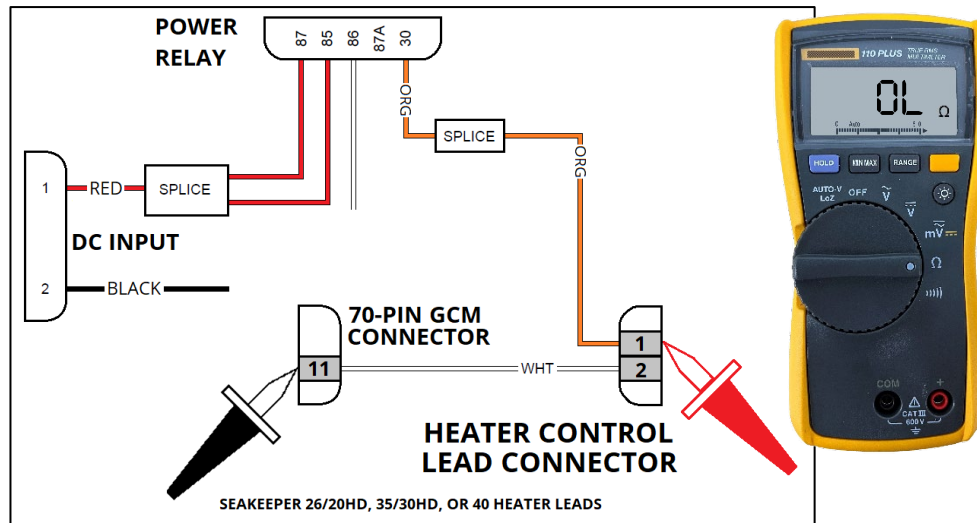

- e. **IF** resistance found is less than "OL" (Open loop), **THEN REPLACE** wire harness.
- f. **RECONNECT** heater or connector plug to wire harness.
9. **RECONNECT** 70-pin GCM and DC Input connector.
10. **RESTORE** all power to Seakeeper.
11. **IF** alarm has not cleared, **THEN REPLACE** GCM.
12. **IF** alarm persists, **THEN:**
- COMPILE** all data taken and a photo of information screen.
 - SUBMIT** test results data and photo to Seakeeper Product Support Team at support@seakeeper.com for review.

***** **END** *****

CODE 44/45

To troubleshoot and repair the “SENSOR POWER HIGH/LOW” alarm (Code 44/45, respectively).

BACKGROUND

These codes will alarm at a voltage higher (5.15VDC) or lower (4.85VDC) than a standard sensor voltage band of 5VDC. The 5VDC is created by the GCM from the 12/24VDC input and is used to power the following: angle sensor, vacuum sensor, thermistors, and brake pressure switch(es). Codes 44 and 45 are implausible to alarm unless damage has occurred to the wire harness or a significant electrical event (surge, such as from a lightning strike) has happened in the vessel’s DC distribution system. If a spike does occur, it is possible that Code 40 would alarm with Code 44. In that event, troubleshoot per Code 40 first; if Code 44 is still in alarm afterward, then proceed with this procedure. Likewise, if a voltage drop occurs and alarms Code 41, troubleshoot that alarm first.

Troubleshooting will focus on the wire harness and sensor connection integrity. The Seakeeper must be power cycled to reset the alarm.

PRECAUTIONS

See [PRECAUTIONS](#) of Introduction section.

PROCEDURE

POWER REQUIREMENTS				
MODEL	HI CURRENT INPUT TO MDB	BREAKER/ FUSE RATING	DC CONTROL POWER INPUT	BREAKER/ FUSE RATING
Seakeeper 2 & 3	12VDC	100 A @ 12VDC	12VDC	15 A
Seakeeper 5/3DC 5/3DC-0001 through 5/3DC-1049	110/230VAC	30 A @ 110VAC 25A @ 230VAC	12VDC	15 A
Seakeeper 5 & 6	110/230VAC	30 A @ 110VAC 25 A @ 230VAC	12VDC	15 A**
Seakeeper 9/7HD	230VAC	20 A	24VDC	10 A**
Seakeeper 16/12HD Up to 16/12HD-193-0912	230VAC	20 A	24VDC	10 A
Seakeeper 18/16/12HD*	230VAC	30 A	24VDC	10 A**
Seakeeper 26/20HD	230VAC	20 A	24VDC	10 A
Seakeeper 35/30HD	230VAC	30 A	24VDC	15 A
Seakeeper 40	230VAC	30 A	24VDC	15 A**
* Seakeeper 16/12HD after 16/12HD-201-0001				
** Two relays exist on harness: 1 power & 1 SW Pump. On models serial numbers: 5/6-2771 and after, 9-3388 and after, 16-194-0001 and after, and ALL Seakeeper 18 and 40 models.				

1. **PERFORM** this procedure in its entirety (multiple failures may cause a single code) **AND RECORD** all test and inspection results for submittal if cause not found.
2. With power aligned, **VISUALLY INSPECT** as follows:
 - a. **INSPECT** individual sensors:
 - i. **UNPLUG** each sensor one by one:
 1. **VERIFY** no corrosion buildup within connectors.
 2. **CHECK** alarm clear.
 - ii. **INSPECT** leads of each sensor for loose wires and crimps.
 - iii. **VERIFY**, at display service screen, (for sensors with a reading) sensor output is in specification and sensible for conditions: e.g., Vacuum sensor not failed at "0 Torr" or thermistor reading not failed at "50°C" in cool environment.
 - iv. **IF** any sensor cleared alarm when disconnected in step 2.a.i **OR** is displaying failed reading from step 2.a.iii, **THEN REPLACE** sensor.

PRODUCT SEAKEEPER SERIES MODELS

Code 44/45

Step 2 continued

- b. **INSPECT** wire harness throughout foundation and guide band:
 - i. **ACTIVATE** Brake Override.
 - ii. **MANUALLY PRECESS** enclosure to check clearances for harness on guide band.
 - iii. **VERIFY** guide band sensor wiring is not rubbing on stringer or Seakeeper foundation/Gimbal cap.
 - iv. **DEACTIVATE** Brake Override.
 - v. **IF** Seakeeper 5/6 or larger, **THEN UNPLUG** guide band connector.

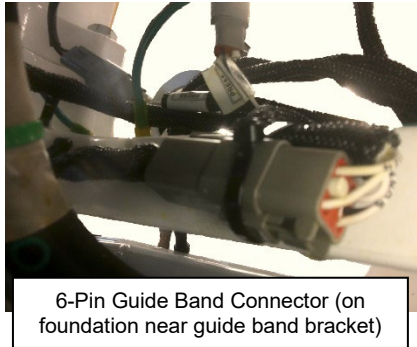

- vi. **INSPECT** pins and sockets loose wires or crimps.
 - vii. **RECONNECT** guide band connector.
3. **IF** any heat or physically damaged sensors or connectors found during visual inspection, **THEN:**
 - a. **PHOTOGRAPH** affected components (wire harness or sensor).
 - b. **REPLACE** affected components (wire harness or sensor).

PRODUCT SEAKEEPER SERIES MODELS

Code 44/45

4. **IF** no sensor or wiring damage found during visual inspection, **THEN PERFORM** following for each sensor:
- a. **TURN OFF** low current DC breaker to Seakeeper.

CAUTION:

Connector damage may result if test probe exceeds 0.10 inch in diameter.

- b. **UNPLUG** GCM 70-pin connector from GCM.
- c. **PERFORM** following for Angle Sensor:

Angle Sensor GCM Pinout

Pin 1: GCM Pin 48 +5VDC supply
 Pin 2: GCM Pin 28 signal voltage
 Pin 3: GCM Pin 2 (Seakeeper 3, 5 (all) & 6)
 GCM Pin 32 (Seakeeper 2, 9/7HD & up)

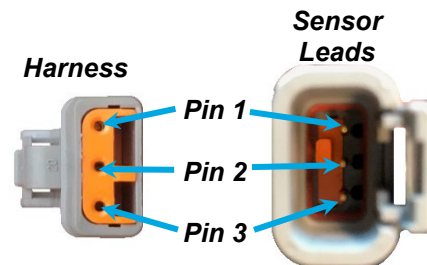

- i. **UNPLUG** angle sensor from wire harness.
- ii. **TEST** for short on angle sensor harness plug between pin **1** and pin **2**.
- iii. **TEST** for short in harness between pin **1** and pin **3**.
- iv. **TEST** for short in harness between pin **3** and pin **2**.
- v. **IF** any test in Step 4.c.ii through 4.c.iv showed a resistance less than 1000Ω, **THEN REPLACE** wire harness.
- vi. **TEST** resistance between three prongs of angle sensor leads.
- vii. **IF** any resistance in Step 4.c.vi is less than 1000Ω, **THEN REPLACE** angle sensor.
- viii. **IF** all checks of angle sensor SATISFACTORY, **THEN RECONNECT** angle sensor.
- ix. **LEAVE DISCONNECTED** GCM 70-pin connector.

Step 4 continued

- d. **PERFORM** following for Vacuum Sensor:
[N/A on many models]
 - i. **DISCONNECT** vacuum sensor from wire harness.
 - ii. **DISCONNECT** bearing temperature thermistors (if equipped) from wire harness.
 - iii. **TEST** for short between pin **1 (B)** and pin **3 (A)** in harness connector.
 - iv. **TEST** for short between pin **1 (B)** and pin **2 (C)**.
 - v. **TEST** for short between pin **2 (C)** and pin **3 (A)**.
 - vi. **IF** any test in steps 4.d.iii through 4.d.v showed resistance less than 1000Ω, **THEN REPLACE** wire harness.
 - vii. **LEAVE DISCONNECTED** vacuum sensor connector.

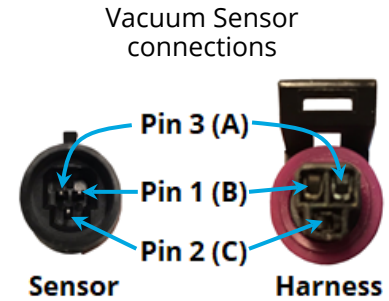

Vacuum Sensor Pin out to GCM:

Pin 1(B): pin 48 (5v Supply)
 Pin 2(C): pin 24 (Signal Voltage)
 Pin 3(A): pin 32 GND on Seakeeper 9 & under
 Pin 3(A): pin 2 (GND) on Seakeeper 16 & above

- e. **PERFORM** following for Bearing Thermistor
[N/A on many models]:
 - i. **DISCONNECT** bearing thermistors.
 - ii. In harness connector, **TEST** for short between pin **1** and pin **2** of UPPER thermistor.
 - iii. **TEST** for short between pin **1** and pin **2** of LOWER thermistor.
 - iv. On thermistor connector, **TEST** resistance across sensor.
 - v. **IF** either test in steps 4.e.ii or 4.e.iii showed resistance less than 1000Ω, **THEN REPLACE** wire harness.
 - vi. **IF** resistance in Step 4.e.iv was below 1000Ω, **THEN REPLACE** thermistor.
 - vii. **RECONNECT** vacuum sensor **AND** bearing thermistors to wire harness.

Thermistor Pin-Out to GCM:

Pin 1: GCM Pin 42 for Upper sensor & Pin 43 for Lower sensor
 Pin 2: GCM Pin 2

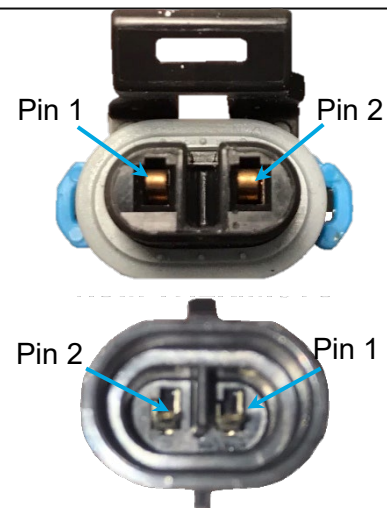

Step 4 continued

f. **PERFORM** following for Brake Pressure Switch(es):

- i. **DISCONNECT** brake manifold pressure switch(es) from wire harness.
- ii. **TEST** for short between pressure switch #1 harness connector pin **1 (A)** and pin **2 (C)**.
- iii. **TEST** for short between pressure switch #2 harness connector pin **1 (A)** and pin **2 (C)**, if applicable.
- iv. **IF** any test in step 4.f.ii or 4.f.iii showed resistance less than 1000Ω, **THEN REPLACE** wire harness.

g. **ENSURE** all connections of wire harness, GCM and sensors are made securely.h. **RECONNECT** low current DC power.5. **DISCONNECT** pressure switch harness connector.6. **PERFORM** following:

- a. With multimeter in DC Volts, **TEST** for 5.0VDC between pin **1 (A)** and pin **2 (C)**.
- b. **IF** voltage between 4.85 and 5.15VDC **AND** alarm persists, **THEN REPLACE** GCM.

7. **CYCLE** DC low-current power.8. **CHECK** alarm clear at display/MFD app.9. **IF** alarm persists, **THEN REPLACE** GCM.**Pressure Switch Pinout to GCM:**

A(1): GCM Pin 25 for Switch 1 and
Pin 27 for Switch 2. (black)
B: NOT USED
C(2): GCM Pin 32 for Seakeeper 9 &
above; Pin 2 for Seakeeper 6 and
below. (white)

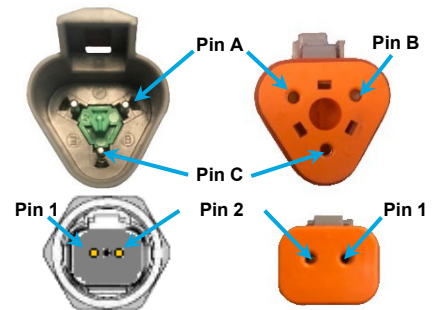

2-Pin Deutsch connector used on
Seakeeper 1, 2, 3, 18, 35, & 40 (ALL)
(5-201-1969 – current)
(6-201-1936 – current)
(9-201-2839 – current)
(16/12HD-194-0001 - current)
(26-0040 to current)

***** **END** *****

PRODUCT SEAKEEPER SERIES MODELS

CODE 72

To troubleshoot and repair the “MOTOR UNDER SPEED” alarm (Code 72).

BACKGROUND

This code will be displayed because the motor is slowing while unlocked in “SEA MODE.” The alarm is triggered at two-thirds (2/3) of the target motor speed. Depending on what caused the drop in speed, other codes may appear with Code 72. If so, troubleshoot the other alarms first. If Code 72 remains active after resetting the other alarms, return to this procedure.

Some causes can be damage to the motor power cable due to rubbing or contact, intermittent power supplied to the drive box, sphere vacuum loss which rises, increased flywheel bearing drag, faulty vessel electrical system, loss in enclosure vacuum, motor winding fault, and Motor Drive Box (MDB) faults.

Megohm testing is performed in this guide to determine the condition of the insulation and potting of the motor drive cable and flywheel motor. Because megohm meters vary in quality and accuracy, the guide uses a time-resistance test that eliminates some of these variables. A meter that can provide a continuous test voltage for 60 seconds is required.

REFERENCES

Applicable Seakeeper Service Drawings on [Dealer Access](#)

PRECAUTIONS

See [PRECAUTIONS](#) of Introduction section.

PROCEDURE**SECTION 1: INITIAL CHECKS**

1. **ENSURE** following:
 - a. **COMPLETE** this procedure in its entirety (Multiple failures may cause a single code)
 - b. **RECORD** all test and inspection results for submittal if cause not found.
2. **IF** Code 128 found in alarm history prior to Code 72, **THEN PERFORM** following:
 - a. **VERIFY** Torr reading on display is above 85 Torr **OR** reading 0 Torr. Note: vacuum sensor fails to "0" Torr when pressure in enclosure rises some point above 250 Torr.

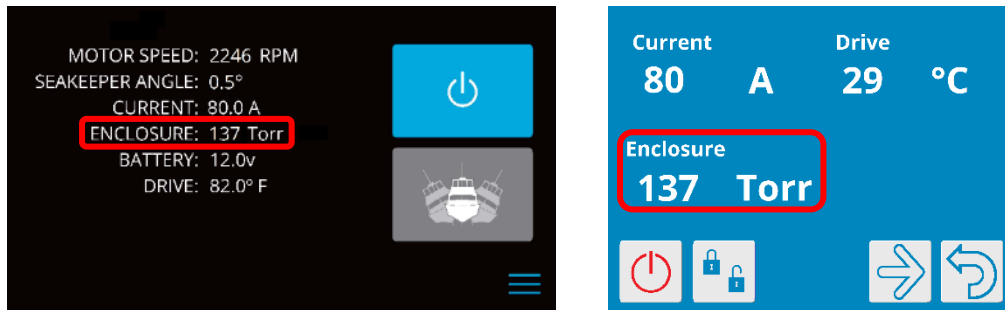

- b. **IF** no vacuum sensor equipped, **THEN CHECK** vacuum pressure with digital vacuum gauge (P/N 40605) per [SWI-129 - Vacuum Gauge Operation](#).
 - c. **RECORD** enclosure pressure: _____ Torr
 - d. **IF** enclosure pressure of greater than 85 Torr or "0" Torr on display, **THEN CONTACT** Seakeeper Product Support Team at support@seakeeper.com to determine actions to restore vacuum.
3. **VERIFY** flywheel at zero RPM at display/MFD app.
4. **TURN OFF** AC or high current DC breaker to Seakeeper.

NOTE:

Overrides would not be available if MDB fault shows "1234 RPM;" Seakeeper would lock-out overrides because of sensed RPM greater than 0 RPM.

5. **IF** AC model Seakeeper display reads "1234 RPM" with flywheel at rest,
THEN:

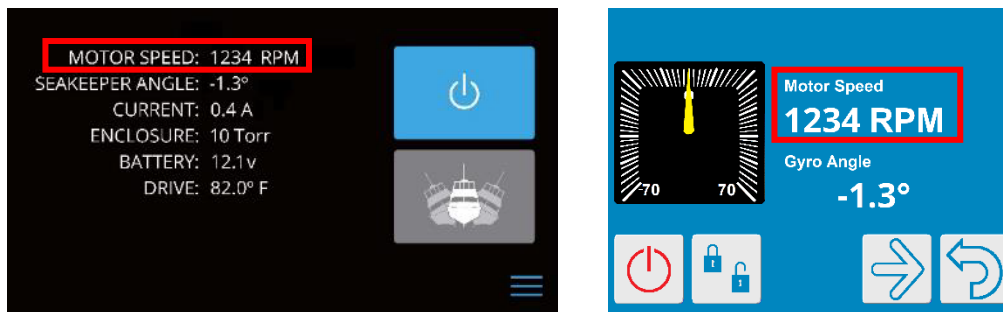

- a. **REPLACE** MDB per [SWI-094](#).
 - b. **RETURN** faulty MDB to Seakeeper.
6. **ACTIVATE** brake override.
7. **MANUALLY PRECESS** enclosure of Seakeeper to observe clearances of motor power cable through whole path of precession.
8. **IF** cable contacts any structure or component in travel,
THEN CAREFULLY INSPECT cable at point of contact.
9. **IF** damage of cable insulation is found,
THEN DOCUMENT damage in photo and retain for later submittal to Seakeeper Product Support Team.
10. **IF** model is an AC-powered Seakeeper,
THEN CONTINUE to [Section 2](#).
11. **IF** model is a DC-powered Seakeeper,
THEN CONTINUE to [Section 3](#).

SECTION 2: AC-POWERED MODELS



WARNING!

SHOCK HAZARD EXISTS WHEN FLYWHEEL ROTATING.
OR POWER APPLIED TO SEAKEEPER.

1. With Seakeeper locked and at zero RPM, **REMOVE** MDB cover.
2. **ENSURE** interior of MDB is free of moisture.
3. With a multimeter in “AC Volts” mode, **MEASURE** voltage at “AC INPUT” terminal.

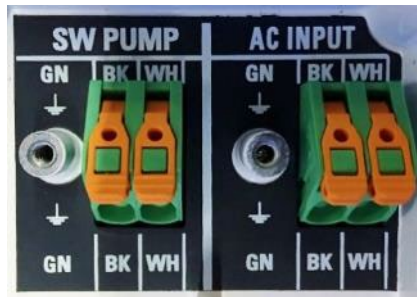

4. **COMPARE** voltage found to voltages of table.

AC MODEL VOLTAGES	
MODEL	VOLTAGE
Seakeeper 5 & 6	110 or 230 VAC
Seakeeper 9 & up	230 VAC

5. **IF** voltage below 80 VAC or above 300 VAC, **THEN TROUBLESHOOT** vessel electrical supply.
6. **VERIFY** leads at “MOTOR” and “AC INPUT” terminals are in correct position by color.
7. **VERIFY** leads are crimped properly, fully inserted into terminal and locked firmly.
8. **IF** any issues found with leads, **THEN CORRECT** issues with motor cable leads.

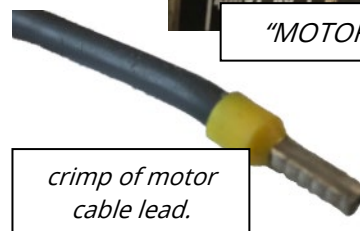

“MOTOR” terminal

crimp of motor cable lead.

PRODUCT SEAKEEPER SERIES MODELS

Code 72

9. **LOOSEN** MDB feed-through grommet.
10. **EXAMINE** motor drive cable insulation at grommet.
11. **IF** damage is found in cable,
THEN DOCUMENT damage in a photo for later submittal to Seakeeper Product Support Team.
12. **TEST** voltage at "400V DC" terminal.
13. **RECORD** voltage at "400V DC" terminal.
Voltage: _____ VDC
14. **IF** voltage at "400V DC" terminal is NOT steady between 390 and 400VDC,
THEN REPLACE MDB.
15. **INSTALL** MDB cover.
16. **TORQUE** ten cover M4 screws to **19 in-lbs (2.2 Nm)**.
17. **IF** issue persists,
THEN CONTINUE to [Section 4](#).

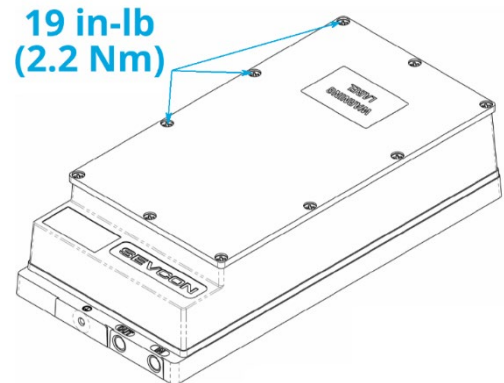
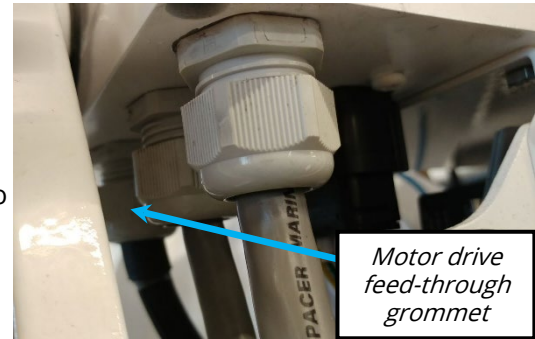

SECTION 3: DC-POWERED MODELS

1. **TURN OFF** high current DC breaker for Seakeeper.
2. **REMOVE** cover at motor terminal contacts **AND** at High DC current input terminals.

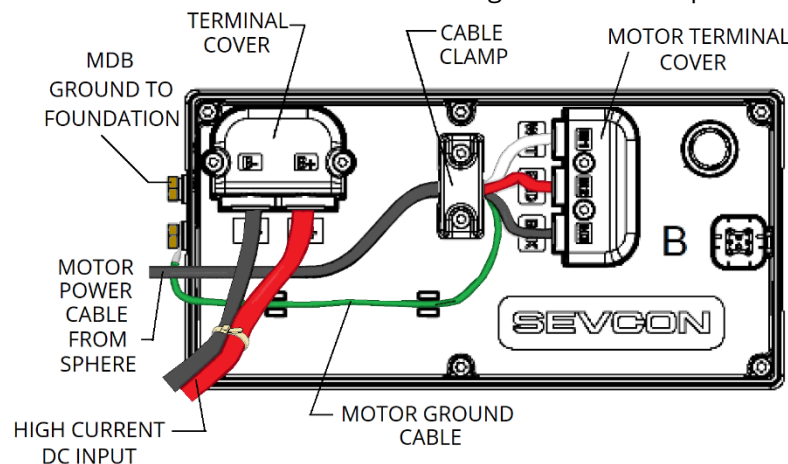

3. **INSPECT** for severe corrosion at contacts or loose crimps.
4. **VERIFY** all terminals torqued per [Torque Specifications](#) section **AND** motor cable leads in proper color location.
5. **TURN ON** high current DC power breaker to Seakeeper.
6. **START** Seakeeper.
7. At full RPM, **UNLOCK** Seakeeper.
8. **MEASURE** high DC voltage at "DC INPUT" terminals during precession operation.
NOTE: Voltage should be 10.0 to 15.0VDC.
9. **IF** not at a proper voltage (10.0 to 15.0 V), **THEN TROUBLESHOOT** vessel's electrical system.
10. **DOCUMENT** any visible damage found with a photograph.
11. **IF** issue persists, **THEN CONTINUE** to [Section 4](#).

SECTION 4: COMPLETION OF TROUBLESHOOTING

1. **IF** cable measurements were satisfactory and alarm still active,
THEN:
 - a. **REPLACE** MDB.
 - b. **RETURN** faulty MDB to Seakeeper.
2. **RESTORE** all Seakeeper power.
3. **IF** alarm persists,
THEN:
 - a. **CAPTURE** video of display service screen during coast down from maximum achieved speed with a visible timer beside display.
 - b. **COMPILE** all data collected and photos.
 - c. **SUBMIT** all data, photos, and videos to Seakeeper Product Support Team at support@seakeeper.com for review.

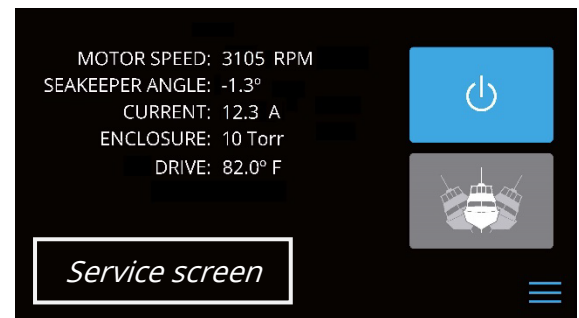

***** **END** *****

PRODUCT SEAKEEPER SERIES MODELS

CODE 75

To troubleshoot and repair the “IMU FAULT” alarm (Code 75).

BACKGROUND

This code alarms when the GCM detects a break in CAN communication. Communication is accomplished through the Seakeeper CAN bus high and low leads. Any component connected to the CAN could break communication, not just the IMU.

The most likely cause for this code is the IMU becoming unplugged from the wiring harness. In factory tests, it has been discovered that Code 75 could appear if the CAN bus high or low lead is shorted; this guide will address this possibility. Other codes would be present in alarm history with Code 75 if this were the cause. Other codes seen may be Code 82: “Drive Age Count,” “Code 35: Display Fault,” and “Code 251: No Connection to Gyro.” Though IMU failure is unlikely, it may need to be replaced if the alarm persists after all other possible causes have been eliminated.

In DC-powered models, the harness modification of SB-90504 may be needed to clear the code.

There are two generations of the IMU, shown in the picture. If replacing a first generation (revision 1) IMU, it will be necessary to ensure an updated GCM and display software are loaded.

Dealers must contact Seakeeper Product Support for assistance in these instances.

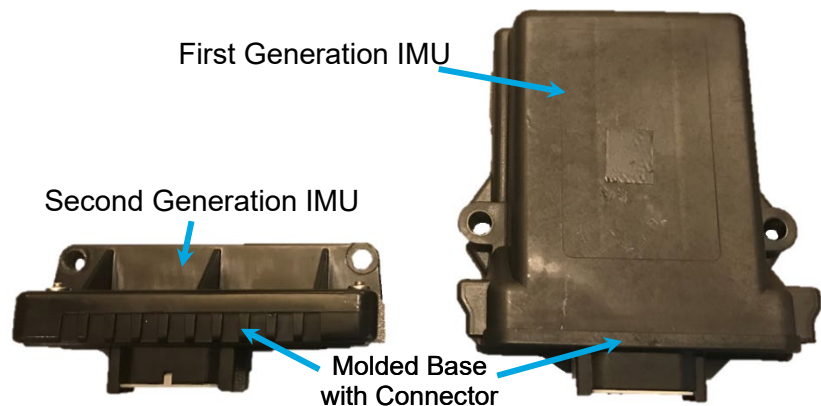
**REFERENCES**

[SB-90504 - CAN CORRECTION Service Bulletin](#)

Applicable model Electrical or Upper Foundation drawing in [Dealer Access](#)

PRECAUTIONS

See [PRECAUTIONS](#) of Introduction section.

PROCEDURE**WARNING!**

PERSONNEL SHOCK HAZARD EXISTS when working on live circuitry.
Seakeeper may start remotely.

1. **ENSURE** zero RPM on display or MFD app.
2. **TURN OFF** all breakers to Seakeeper.
3. **DISCONNECT** IMU harness connector.
4. **VISUALLY INSPECT** all wiring and pins of IMU:
 - a. **CUT** cable ties securing harness near IMU, as necessary.
 - b. **INSPECT** wiring near IMU for exposed leads with damage.
 - c. **INSPECT** IMU connector for loose wires or crimps.

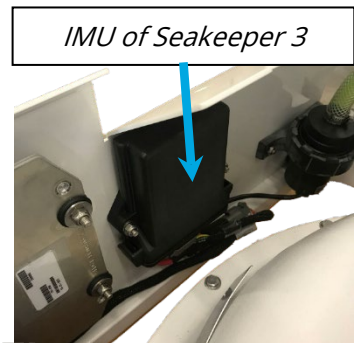

- d. **IF** loose wires or crimps found, **THEN REPAIR** connector.
- e. **IF** damaged wire harness/wires, **THEN REPLACE** wire harness.
- f. **REPLACE** any cable ties cut for inspection.

NOTE:

Connector has two wedge tabs that engage IMU at each side. Three tabs molded into connector prevent connector from being inserted upside down.

5. **RECONNECT** IMU connector, ensuring it is fully seated in IMU.
 - a. **CYCLE** DC control power to Seakeeper.
 - b. **VERIFY** IMU mounted in correct orientation per applicable Electrical or Upper Foundation drawing in [Dealer Access](#).
 - c. **CHECK** alarm clear on display/MFD app.
 - d. **IF** alarm not clear,
THEN INSTALL a new IMU on harness **AND REPEAT** Steps 5.a and 5.b.

6. **IF** model is Seakeeper 2 or 3,
THEN CHECK following:
 - a. **IF** Seakeeper 2 of S/N 2-0001 through 2-0084,
THEN VERIFY harness label near GCM 70-pin connector reads "REV. 8," or later, as shown.
 - b. **IF** Seakeeper 3 of S/N 3-0001 through 3-0443,
THEN VERIFY harness label near GCM 70-pin connector reads "REV. 5," or later, as shown.
 - c. **IF** appropriate harness tag does not appear as in Steps 6.a or 6.b,
THEN PERFORM harness modification procedure of [SB-90504](#).
 - i. **CYCLE** DC control power.
 - ii. **ATTEMPT** to reset alarm at display/MFD app after modification.

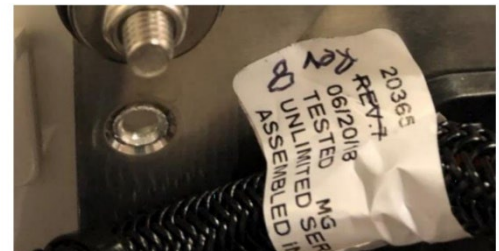

7. **PERFORM AND RECORD** electrical checks of CANbus as follows:

IMU PINOUT	
PIN 1	-12/24 VDC (BLK)
3	CAN-Lo, GCM pin 53 (GRN)
7	Prop Vlv pin D (WHT) } <i>Applicable only to</i>
8	GCM pin 21 (WHT) } <i>Seakeeper 26, 35, & 40</i>
10	CAN-Hi, GCM pin 36 (YLW)
12	+12/24 VDC (ORG)

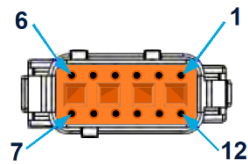

Deutsch DTM06-12SA (FEMALE)



NOTE:

Intermittent opens in a wire may only be seen by manipulating the harness to duplicate precession movement.

 **WARNING!**

PERSONNEL SHOCK HAZARD EXISTS when working on live circuitry.
Seakeeper may start remotely.

- a. With power aligned to Seakeeper, **DISCONNECT** IMU.
- b. **CONFIRM** 12/24VDC at IMU harness connector between pin **12** and pin **1**.
- c. **DISCONNECT** DC low current power supply to Seakeeper **OR TURN OFF** DC low current supply breaker for Seakeeper.
- d. **DISCONNECT** wire harness from MDB.
- e. **DISCONNECT** display connection of Seakeeper to helm display cable or ConnectBox.
- f. **DISCONNECT** wire harness from GCM.

Step 7 continued

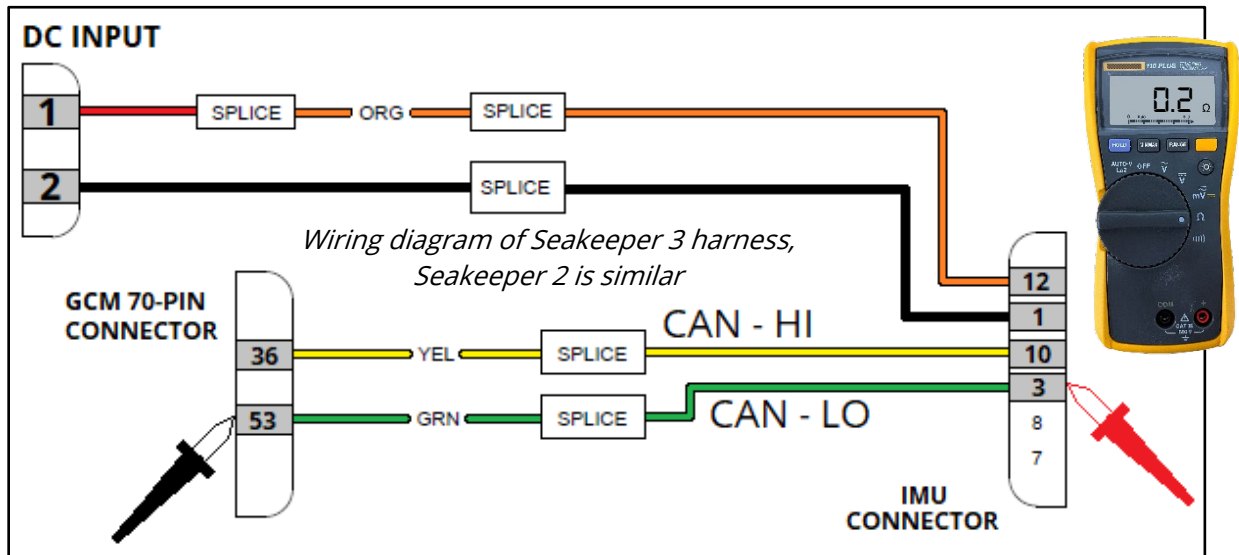
g. With a multimeter in resistance mode, **PERFORM** following checks:

- i. **CONFIRM** resistance below 0.3Ω between IMU pin **3** and GCM pin **53**.
- ii. **CONFIRM** resistance below 0.3Ω between IMU pin **10** and GCM pin **36**.
- iii. **CHECK** for short between IMU pin **3** and **10**.

Step 7.g continued

iv. **CHECK** for short between IMU pin **3** and following pins:

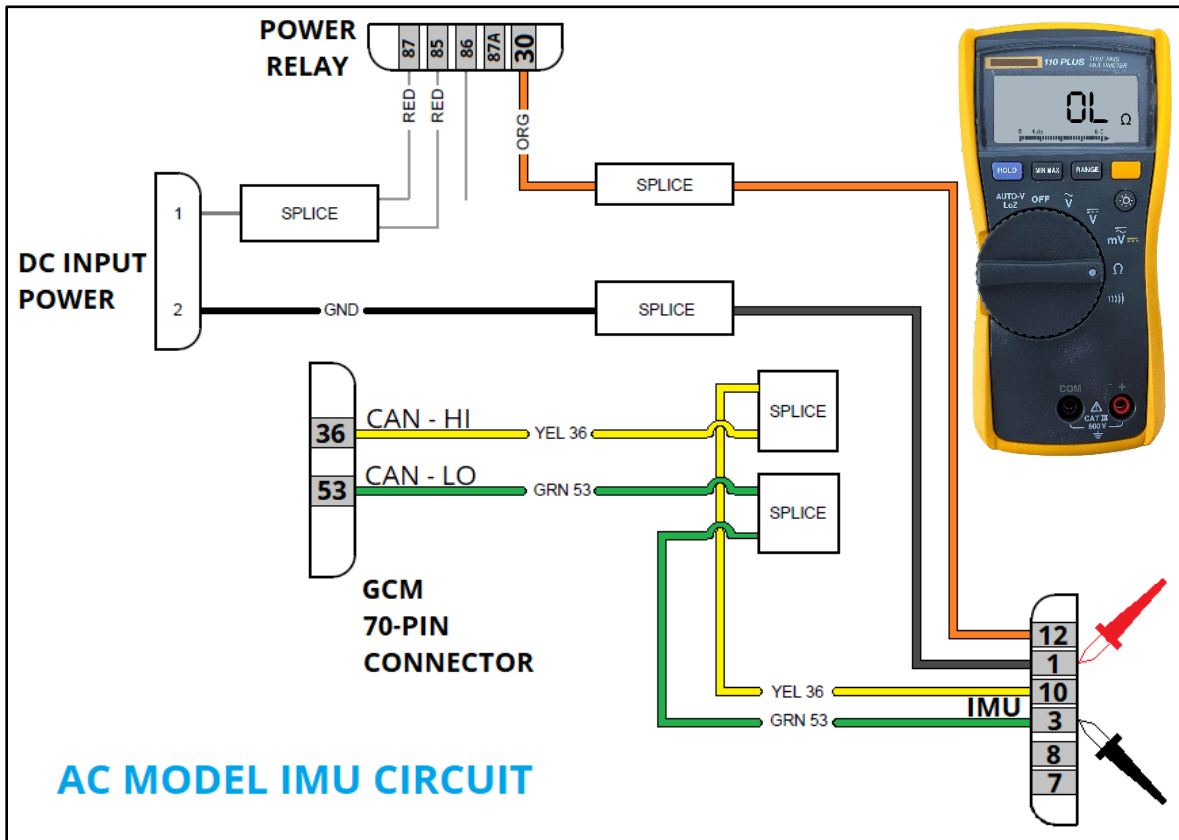

- Pin 1
- Pin 12
- Pin 8 (Seakeeper 26/20HD, 35/30HD, or 40 only)
- Pin 7 (Seakeeper 26/20HD, 35/30HD, or 40 only)

Step 7.g continued

v. **CHECK** for short between IMU pin **10** and following pins:

- Pin **1**
- Pin **12**
- Pin **8** (Seakeeper 26/20HD, 35/30HD, or 40 only)
- Pin **7** (Seakeeper 26/20HD, 35/30HD, or 40 only)

vi. **IF** any check in Step 7.g was UNSATISFACTORY, **THEN REPLACE** wire harness.

8. **IF** other CAN-related alarms are present (i.e., Code 35, 82, 84, 158, 251), **THEN PERFORM** following:

a. **RECONNECT** wire harness connectors to MDB, GCM, and IMU.

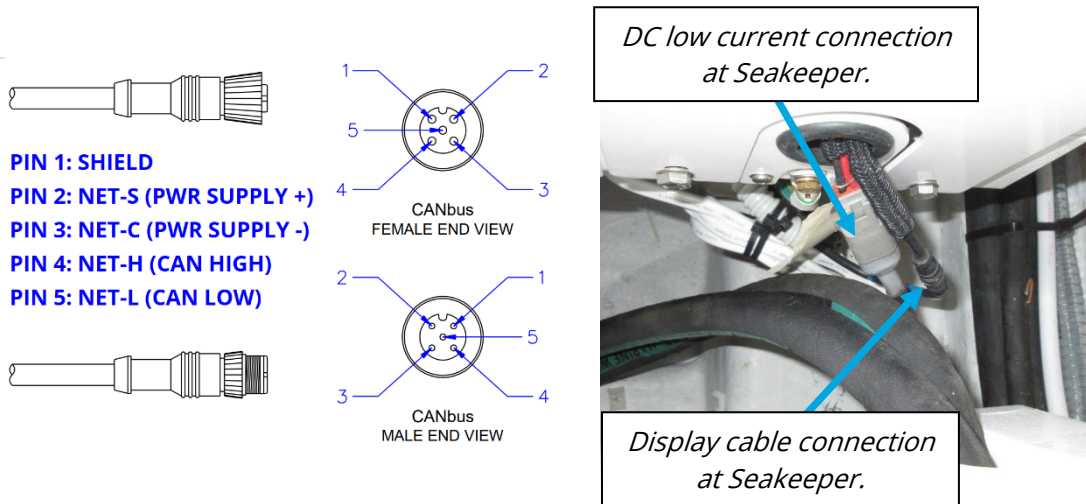

PIN 1: SHIELD
PIN 2: NET-S (PWR SUPPLY +)
PIN 3: NET-C (PWR SUPPLY -)
PIN 4: NET-H (CAN HIGH)
PIN 5: NET-L (CAN LOW)

CANbus FEMALE END VIEW

CANbus MALE END VIEW

DC low current connection at Seakeeper.

Display cable connection at Seakeeper.

Step 8 continued

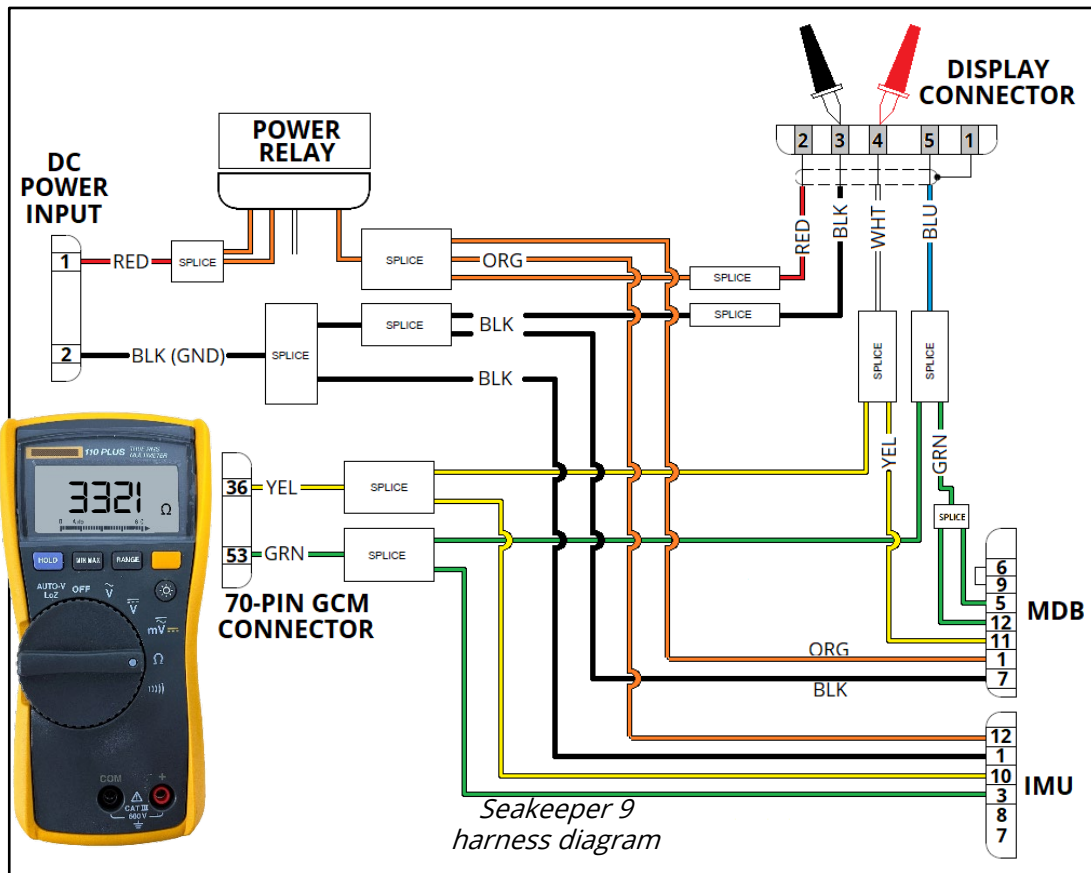
**NOTE:**

- Intermittent opens in a wire may not be seen without manipulating the harness to duplicate movement while operating.
- If terminating resistor attached, this resistance will be about 59-60Ω between pins 4 and 5.

- b. **PERFORM** following on **male** display cable connection of harness:
- VERIFY** resistance of more than 1000Ω exists between pin 5 and pin 2.
 - VERIFY** resistance of more than 1000Ω exists between pin 5 and pin 3.
 - VERIFY** resistance of more than 1000Ω exists between pin 4 and pin 2.
 - VERIFY** resistance of more than 1000Ω exists between pin 4 and pin 3.

Step 8.b continued

- v. **VERIFY** resistance of 120Ω exists between pin 4 and pin 5. [~60Ω with terminating resistor attached]
- vi. **CONFIRM** OPEN LOOP (OL) between pin 4 and pin 1 **AND** between pin 5 and pin 1.
- vii. **KEEP** display cable from Seakeeper to helm station (or ConnectBox) disconnected.

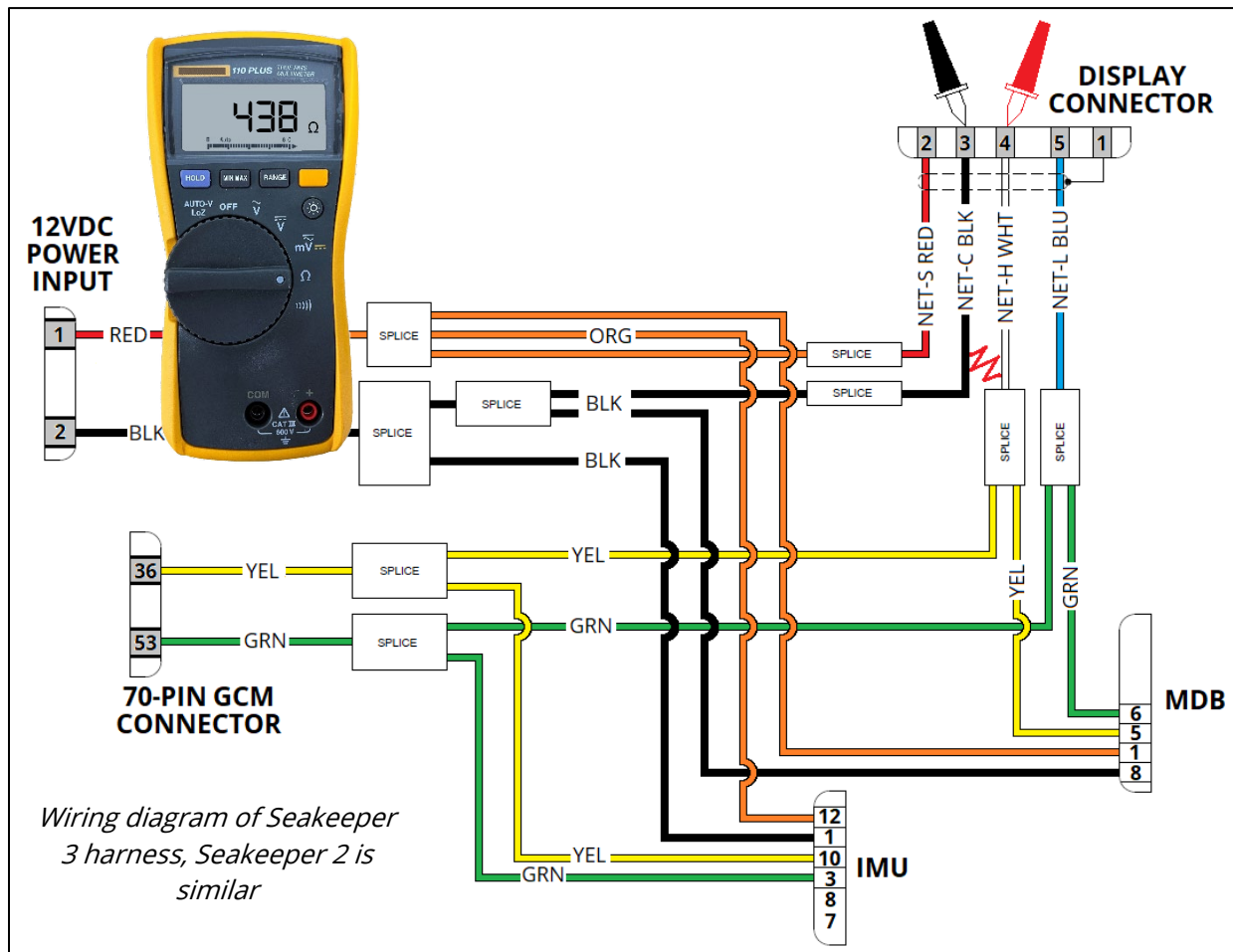

- c. **IF** checks of Step 8.b were SATISFACTORY, **THEN GO TO** helm station and perform following:
 - i. **DISCONNECT** display/ConnectBox from display cable from Seakeeper.
 - ii. **CONFIRM** OPEN LOOP (OL) between any two pins with no terminating resistor attached.

SEAKEEPER TROUBLESHOOTING GUIDE - 106



PRODUCT SEAKEEPER SERIES MODELS

Code 75

Step 8 continued

- d. **IF** short **is** found in step 8.c.ii,
THEN REPLACE display cable from Seakeeper to helm/ConnectBox.
9. **RESTORE** all connections and Seakeeper power.
10. **IF** alarm persists,
THEN CONTACT Seakeeper Product Support Team at support@seakeeper.com with all test results and any photos of Information screen and alarm history, and any photos of damage for review.

*******END*******

PRODUCT SEAKEEPER SERIES MODELS

CODE 76/77

To troubleshoot and repair the “ROLL RATE FAULT” alarm (Code 76) and “YAW RATE FAULT” alarm (Code 77).

BACKGROUND

Both motion faults are sensed in the Inertia Measurement Unit (IMU) and will alarm at 70° per second travel rate in roll and yaw motion. Troubleshooting will concentrate on ensuring the IMU is appropriately oriented and mounted. If this alarm occurs with any other alarms, diagnose them first.

If replacing a first generation IMU, It will be necessary to contact Seakeeper Product Support Team for instructions in updating the GCM and display as well. See the photos for examples of each revision.



*1st Generation IMU (IMU1)
It will appear on info
screen as “IMU: 1.0X”*



*2nd Generation IMU (IMU2)
It will appear on info
screen as “IMU: 2.XX”*

REFERENCES

[SB 90504 - CAN Correction Service Bulletin](#)

Applicable model Service Drawing on [Dealer Access](#)

PRECAUTIONS

See [PRECAUTIONS](#) of Introduction section.

PROCEDURE**WARNING!**

PERSONNEL SHOCK HAZARD EXISTS when working on live circuitry.
Seakeeper may start remotely.

1. **ENSURE** flywheel at zero RPM at display/MFD app.
2. **TURN OFF** low current DC breaker to Seakeeper.
3. **PERFORM** following checks:
 - a. **CONFIRM** IMU is secured tightly to mounting panel.
 - b. **CONFIRM** mounting panel is secure and not vibrating.
4. **ENSURE** nearby components are NOT introducing excessive vibration into Seakeeper or vessel structure during their operation.
5. **IF** not properly installed, **THEN SECURELY FASTEN** IMU in proper orientation.

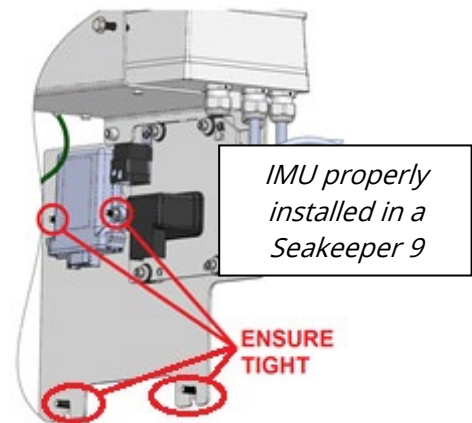

IMU properly installed in a Seakeeper 3



6. **ENSURE** Seakeeper foundation mounting screws torqued per [torque specifications](#) and cannot move.

SEAKEEPER TROUBLESHOOTING GUIDE - 106

PRODUCT SEAKEEPER SERIES MODELS

Code 76/77

7. **VERIFY** IMU connector of harness is fully inserted.
8. **REMOVE** harness IMU connector and inspect connector and pins of IMU for damage or corrosion.
 - **IF** connector is corroded or dirty, **THEN CLEAN** connector and pins and reinsert connector into IMU.
 - **IF** pins of IMU are damaged, **THEN STRAIGHTEN** IMU pins.

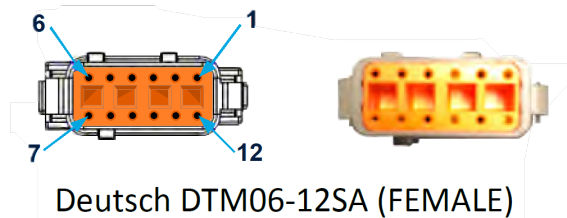
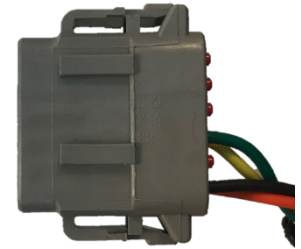

9. **INSPECT** wiring of harness around IMU for signs of damage.
10. **IF** wire harness appears damaged, **THEN REPLACE** wire harness.
11. **CYCLE** DC power to test alarm clear.
12. **IF** Seakeeper 2 or 3 model, **THEN PERFORM** following:
 - a. At GCM connection of wire harness (near front panel), **CHECK** tag for revision of harness.



Seakeeper 2 harness should be Rev. 8 or later.

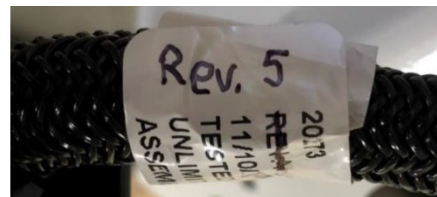

Seakeeper 3 harness should be Rev. 5 or later.

- b. **IF** harness revision is before "REV. 8" for Seakeeper 2 or "REV. 5" for Seakeeper 3, **THEN PERFORM** harness modification per [SB-90504](#).

PRODUCT SEAKEEPER SERIES MODELS

Code 76/77

13. **CYCLE** low current DC power to Seakeeper.
14. **IF** alarm persists,
THEN:
 - a. **REPLACE** IMU.
 - i. **IF** revision 1 IMU (large IMU case),
THEN CONTACT Seakeeper Product Support Team at support@seakeeper.com for instructions.
 - b. **CYCLE** DC power afterward.
15. **IF** alarm persists,
THEN:
 - a. **LOG** CAN data using Seakeeper Service Tool app per [SWI-118](#) for 5 to 10 minutes to capture issue in CAN traffic.
 - b. **CONTACT** Seakeeper Product Support Team at support@seakeeper.com with results of inspections, tests, and any photos for review.

******* END *******

PRODUCT SEAKEEPER SERIES MODELS

CODE 82/84

To troubleshoot and repair:

- “DRIVE AGE COUNT” alarm (Code 82)
- “DRIVE CANBUS FAULT” alarm (Code 84)

BACKGROUND

The GCM triggers this code when it stops receiving messaging from the MDB within a window where it is expected to have received a message. Often, it indicates an abrupt loss of communications due to an open wire or MDB fault. Another possible cause is the CAN Hi, and Low conductors shorted.

Troubleshooting will direct attention to the wiring and the connector at the MDB. The CANbus will be addressed to determine if a short exists on the CAN lines. The CANbus runs from the Seakeeper to the display; the display cable must be eliminated as a possible fault. Because the alarm originates in the GCM, this will be addressed after all other failures are eliminated.

Remember that a technician testing a stationary Seakeeper may not see intermittent faults when testing the wire harness. To eliminate these faults, it is good practice to manipulate the wiring harness while performing electrical checks to catch the sporadic faults that would elude a technician otherwise.

Code 84 is reported to the GCM by the Motor Drive Box (MDB) software, noting it has a CANbus problem internally. One can eliminate hardware issues in this guide to isolate a fault in the MDB. It is more economical to replace a wiring harness than an MDB if it is at fault.

REFERENCES

[SWI-093 - Molex Connector](#)

[SB-90504 - CAN Correction Service Bulletin](#)

PRECAUTIONS

See [PRECAUTIONS](#) of Introduction section.

PROCEDURE**SECTION 1: INITIAL CHECKS****WARNING!**

PERSONNEL SHOCK HAZARD EXISTS when working on live circuitry.
Seakeeper may start remotely.

1. At display or MFD app, **CHECK** Service screen for 1234 RPM speed indication.
 - a. **IF** Service screen shows 1234 RPM,
THEN:
 - i. **REPLACE** MDB per SWI-094.
 - ii. **RETURN** faulty MDB to Seakeeper.
2. **CHECK** Information screen for DRIVE software versions populated.

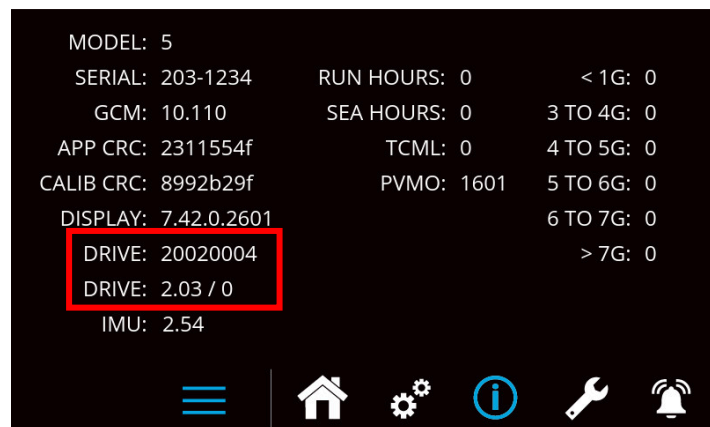
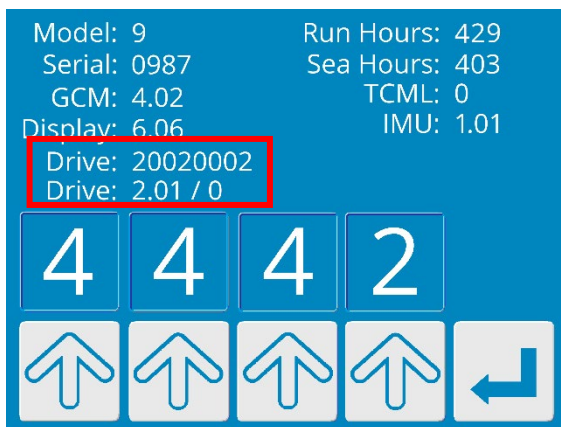

3. **ENSURE** flywheel at zero RPM at display/MFD app.
4. **TURN OFF** all Seakeeper breakers.

5. **VERIFY** connector at MDB is fully inserted.

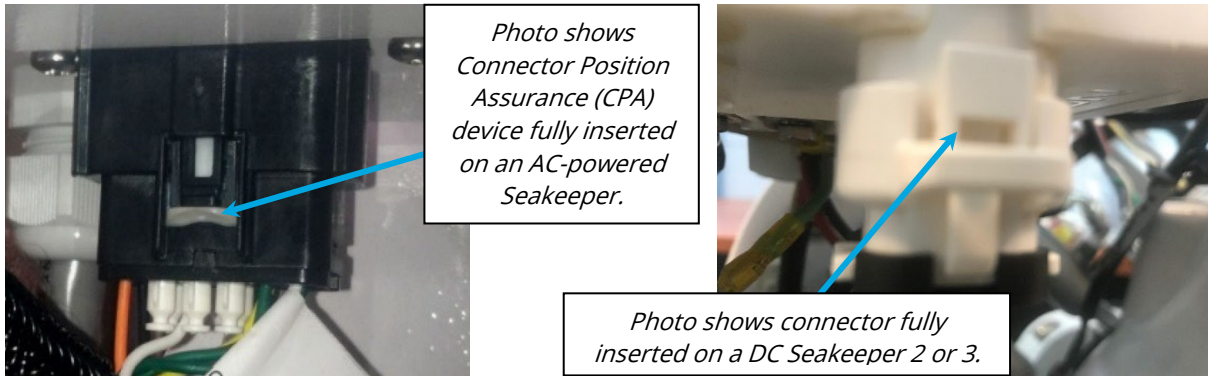

- a. **IF** MDB connector not fully inserted, **THEN:**
 - i. **INSERT** connector.
 - ii. **REPEAT** steps 1 and 2 **AND CHECK** alarm clear.

6. **IF** equipped with 5" display or remote-mounted ConnectBox, **THEN DISCONNECT** display CAN cable to 5" display/remote ConnectBox from Seakeeper wire harness.

7. **PERFORM AND RECORD** following tests on male connector from wire harness:

NOTE:

Intermittent opens in a wire may only be seen by manipulating the harness to duplicate operation movement.

- a. **VERIFY** resistance of more than 1000Ω exists between pin **5** and pin **2**.
- b. **VERIFY** resistance of more than 1000Ω exists between pin **5** and pin **3**.
- c. **VERIFY** resistance of more than 1000Ω exists between pin **4** and pin **2**.

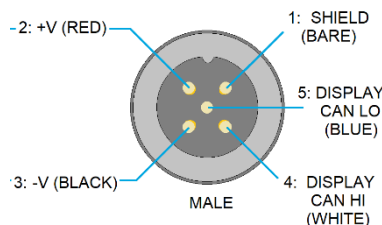

- d. **VERIFY** resistance of more than 1000Ω exists between pin **4** and pin **3**.

Section 1, Step 7 continued

- e. **VERIFY** resistance of 120Ω exists between pin **4** and pin **5**. [**NOTE:** If terminating resistor attached, this resistance will be about $59-60\Omega$ in this measurement.]
 - f. **VERIFY** OPEN LOOP (OL) exists between pin **4** and pin **1** **AND** between pin **5** and pin **1**.
8. **RECONNECT** display cable from helm/ConnectBox to Seakeeper wire harness.
 9. **GO TO** helm station and perform following:
 - a. **DISCONNECT** terminating resistor from T-fittings at end of Seakeeper CAN cable.
 - b. **DISCONNECT** CAN cable from back of display/ConnectBox.
 - c. **CONFIRM** T-fitting and all cable junctions are tight and corrosion free.
 - d. **CONFIRM** OPEN LOOP (OL) between any two pins of disconnected display cable with no terminating resistor attached.
 - i. **IF** short found (less than 1000 ohms), **THEN REPLACE** all display cables and T-fittings from Seakeeper to helm.
 - e. **REATTACH** terminating resistor to T-fitting at end of Seakeeper display cable.
 - f. **VERIFY** resistance of approx. 60Ω between pin **4** and **5** of disconnected display cable.
 - g. **IF** no issues found in display CAN wiring, **THEN REMAKE** all connections.
 10. **PROCEED** to appropriate section per model.

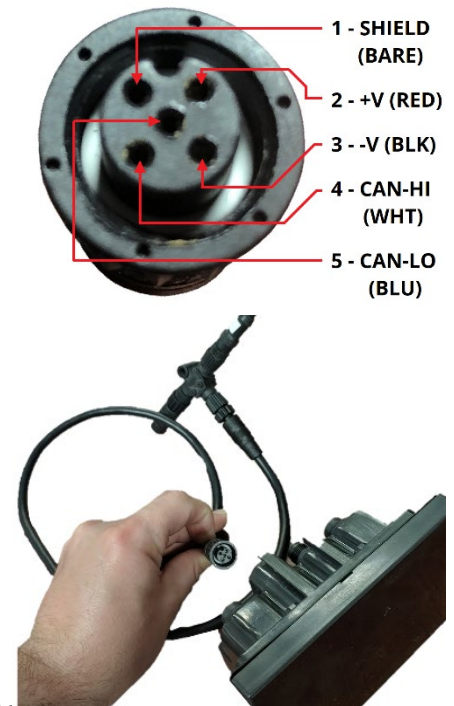

[Section 2: AC Models - Seakeeper 5 and above\)](#)

[Section 3: DC Models - Seakeeper 2 or 3](#)

SECTION 2: AC-POWERED MODELS

1. With all Seakeeper power removed, **REMOVE** MDB connector as follows:
 - a. **PULL** white CPA tab with fingertip to out position.
 - b. With thumb, **PRESS** on locking tab until it releases from connector housing on MDB.
 - c. While continuing to press locking tab, **GRASP** harness connector with index finger **AND PULL AWAY** straight from MDB.

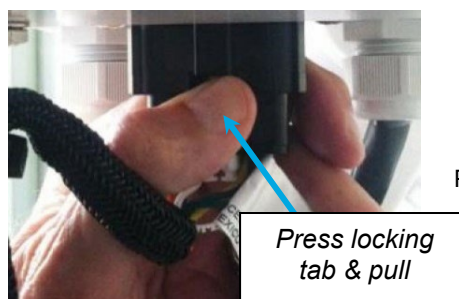
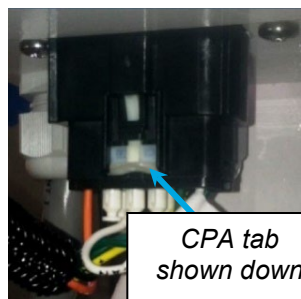

2. **VERIFY** connector wiring per table:

REARVIEW OF HARNESS CONNECTOR			
Wire Color/Description	Pin No.	Pin No.	Wire Color/Description
Orange (+12/24VDC)	1	12	Green (CAN1-)
PLUG	2	11	Yellow (CAN1+, Ckt 36)
PLUG	3	10	PLUG
PLUG	4	9	White (Gnd) jumper w/ pin 6
Green (CAN1-)	5	8	PLUG
White (Gnd) jumper w/ pin 9	6	7	Black (Gnd)

3. **REMOVE** white cover of connector.
4. **CONFIRM** pins are inserted, as shown.
5. **TUG** on wires from back to ensure pin-to-wire crimps are secure **AND** pins locked into connector.
6. **IF** issues found in MDB connector, **THEN CONTACT** Seakeeper Product Support Team at support@seakeeper.com for repair guidance.
7. **DISCONNECT** GCM 70-pin connector.
8. With multimeter in Resistance mode, **PERFORM AND RECORD** following measurements:



SEAKEEPER TROUBLESHOOTING GUIDE - 106



PRODUCT SEAKEEPER SERIES MODELS

Code 82/84

- a. **CONFIRM** below 0.3Ω between MDB pin 11 and GCM pin 36.
- b. **CONFIRM** below 0.3Ω between MDB pin 5 and GCM pin 53.
- c. **CONFIRM** below 0.3Ω between MDB pin 12 and GCM pin 53.



1: 12/24VDC, ORG
2-4, 8 & 10: PLUG
5: CAN-, GRN
6: Jumper w/ 9, WHT
7: GND, BLK
9: Jumper w/ 6, WHT
11: CAN+, YEL
12: CAN-, GRN



AC-powered Seakeeper MDB Molex Connector

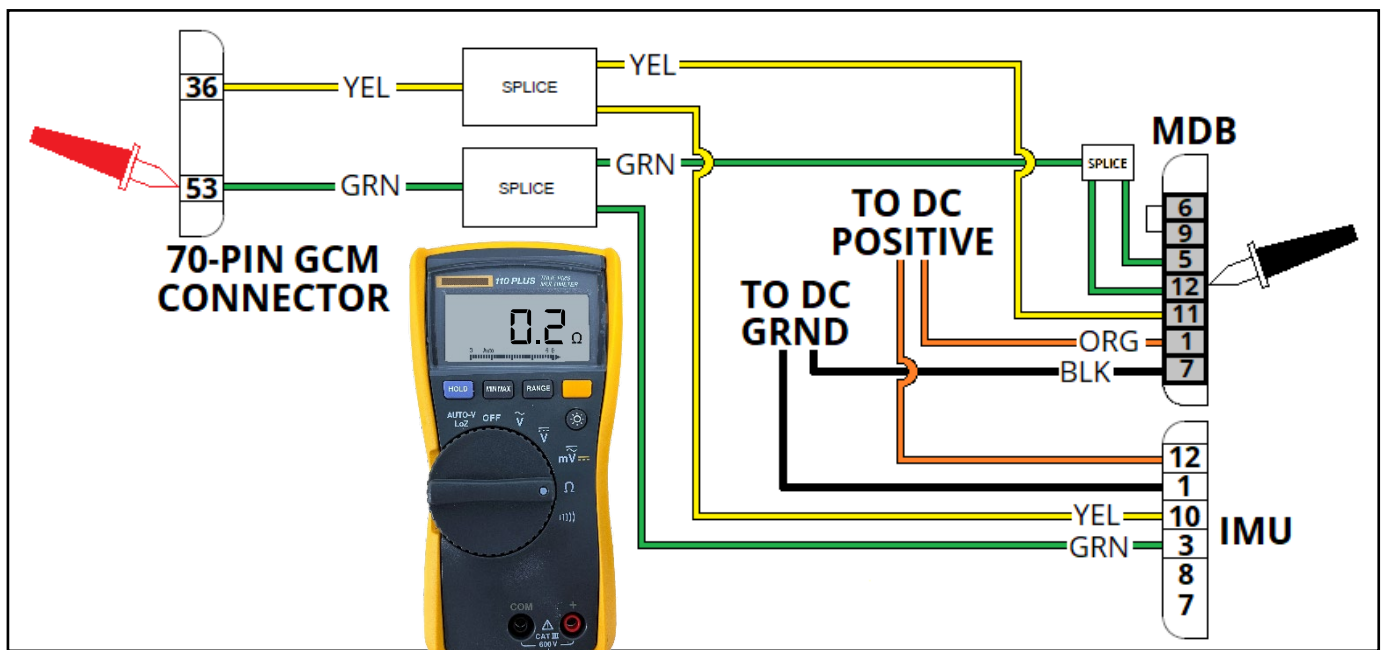

PRODUCT SEAKEEPER SERIES MODELS

Code 82/84

Section 2, Step 8 continued

- d. **INSPECT** for bent pins on MDB and GCM.

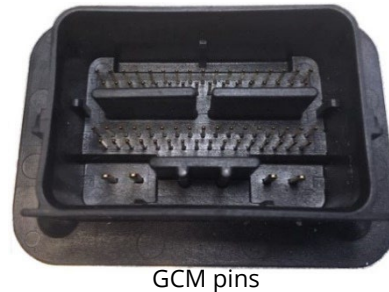
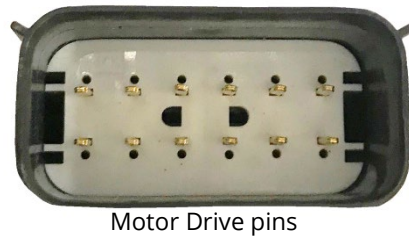

- i. **IF** pin(s) found bent,
THEN REPAIR pin(s).
9. **TURN ON** DC control power breaker to Seakeeper.
10. **MEASURE** for DC input voltage present between pin **1** and pin **7** of motor drive (Molex) connector.

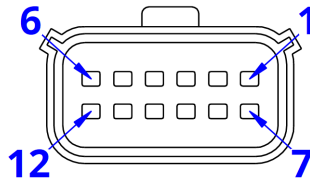

11. **IF** voltage not present and no main power relay code in alarm in Step 10,
OR any resistance in Step 8 **UNSATISFACTORY**,
THEN REPLACE wire harness.
12. **CHECK** alarms clear.
13. **IF** alarm persists,
THEN SUBMIT test results data and any photos to Seakeeper Product Support Team at support@seakeeper.com.

SECTION 3: DC-POWERED MODELS

1. With all Seakeeper power removed, **DISCONNECT** MDB connector as follows:



- a. **PULL OUT** locking wedge tab.
 - b. While pulling out on lock wedge tab, **PULL DOWN** on connector from MDB.
2. **VERIFY** connector wiring per table below:

Wire Description	Pin No.
Orange +12VDC	1
PLUG	2
PLUG	3
PLUG	4
Yellow CAN1+	5
Green CAN1-	6
PLUG or Green	7
Black Ground	8

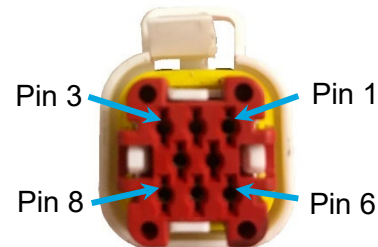

3. **IF** there is uncut green wire in pin **7**, **THEN PERFORM** modification per [SB-90504, CAN Correction](#) Procedure.
4. **TUG** on wires from back of connector to ensure pin-to-wire crimps are secure **AND** pins locked into connector.
5. **IF** issues identified with connector, **THEN CONTACT** Seakeeper Product Support Team for repair guidance.
6. **DISCONNECT** GCM 70-pin connector.

SEAKEEPER TROUBLESHOOTING GUIDE - 106



PRODUCT SEAKEEPER SERIES MODELS

Code 82/84

7. With multimeter in resistance mode, **PERFORM AND RECORD** following measurements:
 - a. **CONFIRM** below 0.3Ω between MDB pin **5** and GCM pin **36**.
 - b. **CONFIRM** below 0.3Ω between MDB pin **6** and GCM pin **53**.

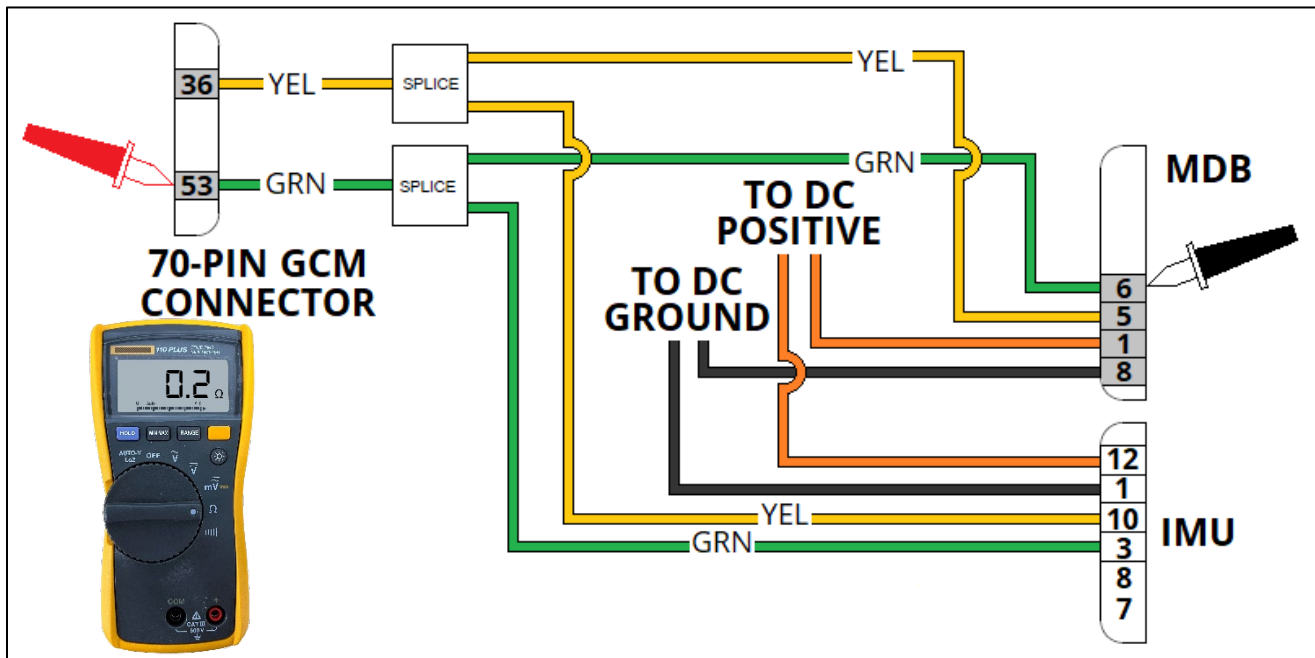
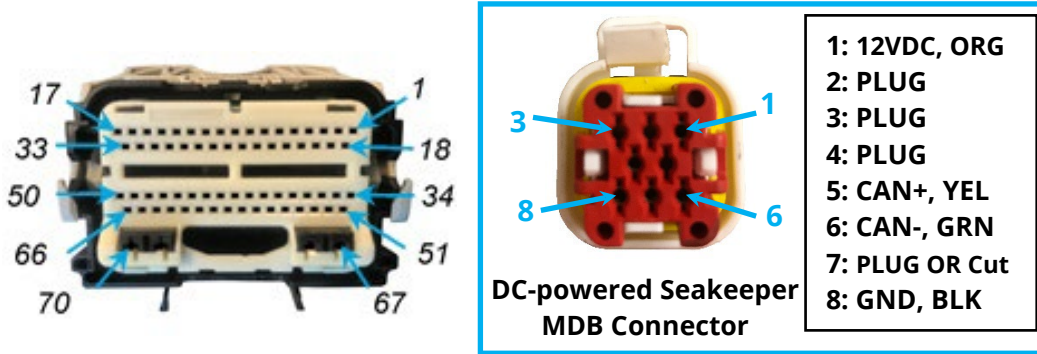

- c. **IF** any measurement **UNSATISFACTORY**, **THEN REPLACE** wire harness.

8. **INSPECT** for damage to pins of MDB and GCM.

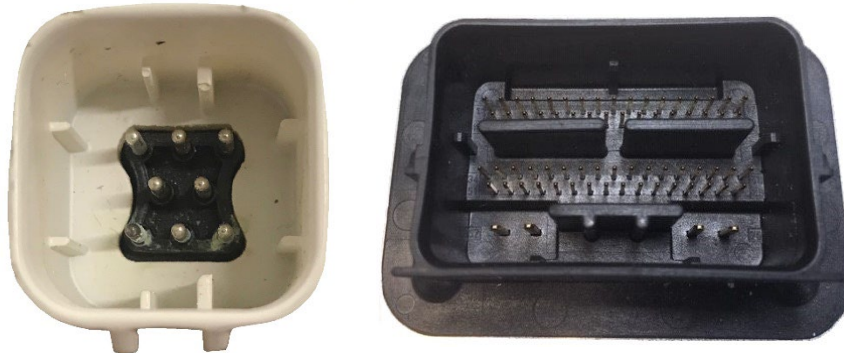

9. **RECONNECT** all connectors of harness.
10. **TURN ON** all breakers to Seakeeper.
11. **CHECK** all alarms clear.
12. **IF** alarm persists,
THEN CONTACT Seakeeper Product Support Team at support@seakeeper.com with all test results.

******* END *******

PRODUCT SEAKEEPER SERIES MODELS

CODE 83

To troubleshoot and repair the “DRIVE VOLTAGE FAULT” alarm (Code 83).

BACKGROUND

The MDB reports this code by measuring the output voltage to the motor. It usually indicates issues with the motor's tuning, shorting within the motor power cables or motor windings, shorting due to cable shielding, or an internal fault in the MDB.

Code 90 (Motor Fault alarm) may accompany code 83. The reason may be a software glitch requiring the replacement of the MDB. This guide will address software issues.

This guide performs megohm testing to determine the condition of the insulation and potting of the motor drive cable and flywheel motor. Because megohmmeters vary in quality and accuracy, the guide uses a time-resistance test that eliminates some of these variables. A meter that can provide a continuous test voltage for 60 seconds is required.

REFERENCES

[SWI-124 - Seakeeper Motor Lead Testing](#)

PRECAUTIONS

See [PRECAUTIONS](#) in Introduction section.

PROCEDURE**SECTION 1: AC-POWERED MODELS****NOTE:**

Intermittent opens in a wire may not be seen without manipulating the harness to duplicate movement of precession.

**WARNING!**

PERSONNEL SHOCK HAZARD EXISTS when working on live circuitry.
Seakeeper may start remotely.

1. **PERFORM** this procedure in its entirety (Multiple failures may cause a single code) **AND RECORD** results of all inspections and tests.
2. At display or MFD app, **VERIFY** RPM indication does not read "1234 RPM".
 - a. **IF** Service screen reads 1234 RPM, **THEN REPLACE** faulty MDB.
3. **TURN OFF** AC breaker to Seakeeper.
4. **ENSURE** Molex harness connector to MDB securely inserted.

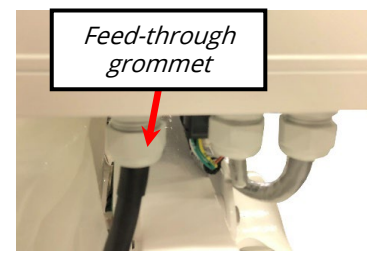
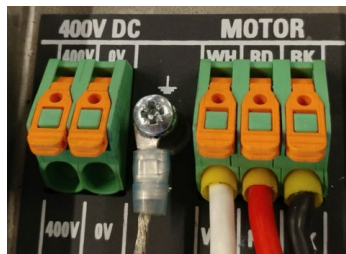

5. **REMOVE** MDB cover to expose "MOTOR" lead connections for following checks:
 - a. **PULL** on crimps at end of each motor cable lead to ensure securely fastened.
 - b. **LOOSEN** MDB feed-through grommet **AND EXAMINE** motor drive cable insulation at grommet.
 - c. **ENSURE** interior of MDB is free of moisture.
6. **TURN ON** AC breaker to Seakeeper.



- With a multimeter on AC Volts, **TEST AND RECORD** voltage at “AC INPUT” terminal per Table 1.

TABLE 1: AC MODEL VOLTAGES	
MODEL	AC VOLTAGES
Seakeeper 5 (Legacy), 6 & 5	110 or 220 VAC
Seakeeper 9/7HD and above	220 VAC only

- IF** voltage below 99/198 VAC or above 121/242 VAC, **THEN TROUBLESHOOT** vessel electrical supply.

NOTE:

If model has DC-powered seawater pump, Steps 9 through 12 are NOT APPLICABLE.

- At display/MFD app, **ACTIVATE** SW Pump Override.
- CONFIRM** voltage at “SW PUMP” terminal is same as “AC INPUT” voltage.
- IF** seawater pump fails to operate, **THEN REMOVE AND BENCH TEST** seawater pump to verify pump operable.
 - IF** seawater pump motor failed, **THEN CONTINUE** in procedure.
- DEACTIVATE** SW Pump Override.
- TURN OFF** AC breaker to Seakeeper.

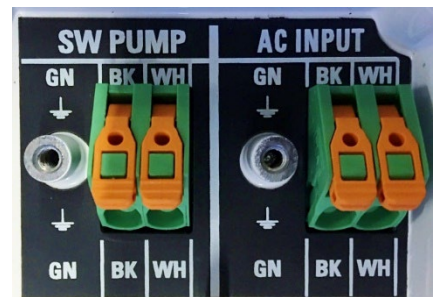

Testing SW Pump voltage

PRODUCT SEAKEEPER SERIES MODELS

Code 83

14. **IF** MDB has metallic-brushed grommet bushing in feed-through opening, as shown to right, **THEN REMOVE** wired bushing at MDB grommet.
15. **PERFORM** testing of motor leads per [SWI-124 - Seakeeper Motor Lead Testing](#).
16. With a multimeter in "DC Volts" mode, **TEST** voltage at "400V DC" terminal.
17. **IF** alarm is currently present and does not clear, **THEN:**
 - a. **INSERT** meter probes into 400v bus terminals.
 - b. With AC power aligned to drive, **CYCLE** DC power.
 - c. **ENSURE** meter reads 390 to 400 briefly before alarm triggers and it begins to drop.
18. **DOCUMENT** any visible damage found with a photograph and all test results.

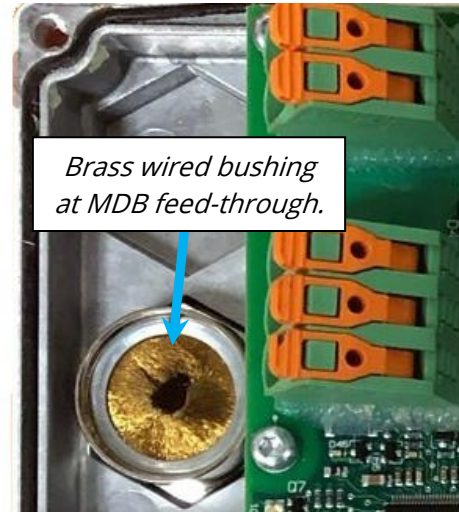
**NOTE:**

It is possible that one fault leads to other faults. These steps assume a series of faults may have occurred from one initial fault.

19. **IF** motor lead testing or 400V voltage check showed UNSATISFACTORY test results, **THEN:**
 - a. **COMPLETE** form [SF-90683 – Pre-FRB Swap Checklist](#).
 - b. **SUBMIT** data and form to Seakeeper Product Support Team at support@seakeeper.com.
20. **RE-ATTACH** all motor cable leads to respective terminal.
21. **INSTALL** MDB cover.
22. **TORQUE** ten M4 Phillips head screws of cover to **19 in-lbs (2.2Nm)**.
23. **TURN ON** all breakers to Seakeeper.
24. **IF** issue persists, **THEN CONTINUE** to [Section 3](#).

SECTION 2: DC-POWERED MODELS**WARNING!**

PERSONNEL SHOCK HAZARD EXISTS when working on live circuitry.
Seakeeper may start remotely.

1. **ENSURE** flywheel at zero RPM at display/MFD app.
2. **TURN OFF** high current DC breaker to Seakeeper.
3. **REMOVE** cover at motor drive cable contact posts and at High DC current input terminals.
4. **INSPECT** for severe corrosion at contacts or damage to cables.
5. **TURN ON** high current DC power breaker to Seakeeper.
6. **MEASURE** High DC voltage at "INPUT" terminals.

NOTE: Voltage should be 10.0 to 15.0VDC.



**SEAKEEPER 2 & 3 MDB
(BOTTOM VIEW)**

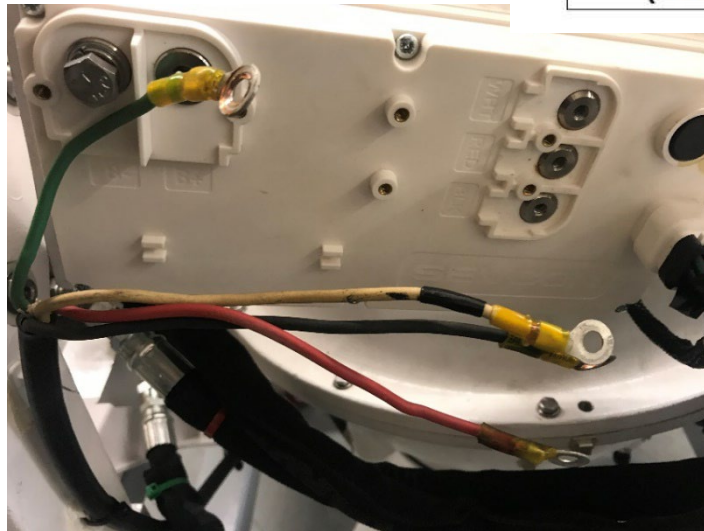

7. **IF** voltage measured at input was not 10.0 to 15.0VDC, **THEN TROUBLESHOOT** vessel electrical system.
8. **PERFORM** testing of motor leads per [SWI-124 - Seakeeper Motor Lead Testing](#).
9. **DOCUMENT** results of all measurements and photograph any damage.

PRODUCT SEAKEEPER SERIES MODELS

Code 83

10. **IF:**

- motor drive cable has any phase-to-phase resistance greater than 2.0Ω,
- any phase resistance is significantly higher than other two, **OR**
- UNSATISFACTORY megohm results,

THEN CONTACT Seakeeper Product Support Team at support@seakeeper.com with all data recorded.

**WARNING:**

SHOCK HAZARD EXISTS BECAUSE OF CAPACITANCE FROM MEGOHM TESTING.

11. **RE-ATTACH** all motor cable leads to respective terminal.
12. **TORQUE** terminal leads per [Torque Specifications](#) section.
 - a. **ENSURE** lock washers are flattened after torquing as shown.
13. **INSTALL** cover at motor drive cable contact posts and High DC current input terminals.
14. **TURN ON** all Seakeeper breakers.
15. **IF** issue persists,
THEN CONTINUE to Section 3 (next page).



SECTION 3: COMPLETION OF TROUBLESHOOTING

1. **IF** alarm persists after faulty component replacement,
THEN:
 - a. **COMPILE** all data taken from testing and a photo of information and alarm history screens.
 - b. **CYCLE** DC power to Seakeeper to reset code(s).
 - c. While in Service screen of display/MFD app (seen in image), **PRESS** START to spool unit.
 - d. **RECORD** one minute video of display while spooling until alarm activated.
 - e. **SUBMIT** test results data, video and photos to Seakeeper Product Support Team at support@seakeeper.com for review.

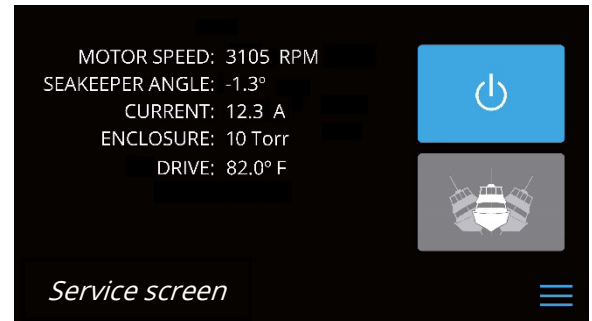

******* END *******

PRODUCT SEAKEEPER SERIES MODELS

CODE 85-93

To troubleshoot and repair the various internal MDB faults that can occur:

- "DRIVE SOFTWARE FAULT" alarm (Code 85).
- "DRIVE MEMORY FAULT" alarm (Code 86)
- "DRIVE CONFIGURATION INCORRECT" alarm (Code 87)
- "DRIVE WIRING FAULT" alarm (Code 88)
- "DRIVE MOTOR CONTROL FAULT" alarm (Code 89)
- "MOTOR FAULT" alarm (Code 90)
- "DRIVE HARDWARE INCOMPATIBLE" alarm (Code 91)
- "DRIVE MOSFET* FAULT" alarm (Code 92)
- "DRIVE IGBT** FAULT" alarm (Code 93)

* MOSFET: Metal-Oxide-Semiconductor Field-Effect Transistor

** IGBT: Insulated Gate Bipolar Transistor

BACKGROUND

These codes will be reported by the Gyro Control Module (GCM) on Motor Drive Box (MDB) internal issues on all Seakeeper series models. All will cause the Seakeeper to secure power to the flywheel motor and lock the unit, and the resolution of the fault will be required before allowing a start. Each is from the monitoring component for which they are named and alarm at a given time delay of milliseconds of the error not clearing. The outlier is Code 90: Motor Fault. It occurs much more rapidly than the others on the list. It will also be seen to accompany other electrical faults at times.

Codes 85 through 87 will address faults within the software programmed into the MDB. The appropriate code will be triggered if the software fails in any start-up programmed self-checks. The failed software will likely require MDB replacement or reprogramming.

Codes 88 through 93 are also from the MDB self-checks but address a component hardware issue, either within the MDB's printed circuit board or in the flywheel motor or its associated wiring. Troubleshooting these codes will require inspection of exterior wiring, voltages, and continuity, which are satisfactory.

Code 90 stands out from the rest as it is not from the MDB self-checks. Instead, it is from the system monitoring flywheel motor speed. When it detects a speed error, it will produce the code.

Codes 92 and 93 indicate an issue within the MDB's circuitry: a short circuit or an open has developed on the circuit board. These may require MDB replacement without much inspection of the Seakeeper other than verifying connectors and associated wiring.

PRODUCT SEAKEEPER SERIES MODELS

Code 85 - 93

This guide performs megohm testing to determine the condition of the insulation and potting of the motor drive cable and flywheel motor. Because megohmmeters vary in quality and accuracy, the guide uses a time-resistance test that eliminates some of these variables. A meter that can provide a continuous test voltage for 60 seconds is required.

REFERENCES

[SB-90504 - CAN Correction service bulletin](#)

[SWI-124 - Seakeeper Motor Lead Testing](#)

PRECAUTIONS

See [PRECAUTIONS](#) in Introduction section.

PROCEDURE**SECTION 1: INITIAL CHECKS**

1. **ENSURE** following:
 - a. **PERFORM** this procedure in its entirety (Multiple failures may cause a single code).
 - b. **RECORD** results of all inspection and tests.



WARNING:

PERSONNEL SHOCK HAZARD EXISTS when working on live circuitry.
Seakeeper may start remotely.

2. **ENSURE** flywheel at zero RPM at display/MFD app.
3. **TURN OFF** all Seakeeper power breakers.
4. **INSPECT** motor terminal connections are tight at MDB and not shorting.

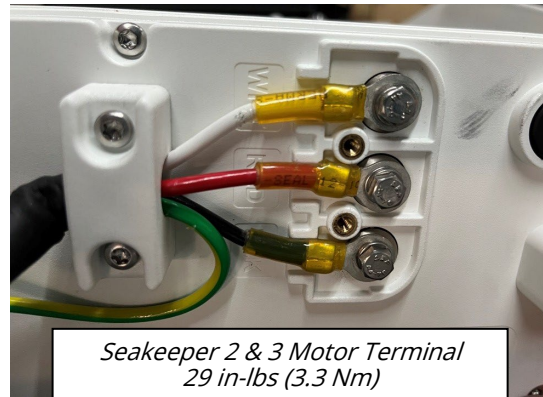
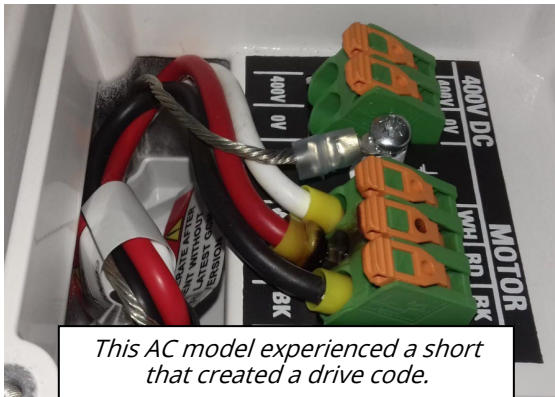

5. **CONTINUE** to appropriate section below:
 - [Section 2](#) for AC-powered models
 - [Section 3](#) for DC-powered models.

SECTION 2: AC-POWERED MODELS



WARNING:

PERSONNEL SHOCK HAZARD EXISTS when working on live circuitry.
Seakeeper may start remotely.

1. **ENSURE** flywheel at zero RPM at display or MFD app.
2. **TURN OFF** AC breaker to Seakeeper.
3. **REMOVE** MDB cover to expose "MOTOR" lead connections for following checks:
 - a. **SAVE** all ten M4 cover screws in safe place.
 - b. **INSPECT** crimps at end of each motor cable lead to ensure they are in good condition.
 - c. **LOOSEN** MDB feed-through grommet **AND EXAMINE** motor drive cable insulation at grommet for damage.
4. **ENSURE** interior of MDB is free of moisture.
5. **TURN ON** AC breaker to Seakeeper.
6. With multimeter on AC Volts, **TEST** voltage at AC INPUT terminal per Table 1.

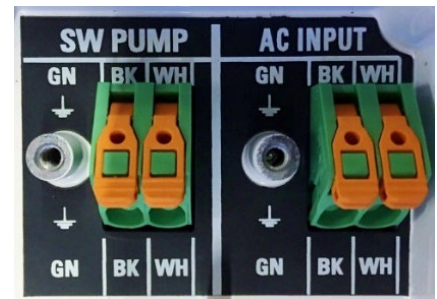

TABLE 1: VOLTAGES FOR MODELS		
MODEL	AC VOLTAGE	DC VOLTAGE
Seakeeper 5 (EM), 6 or 5	97.2 - 132, or 188 - 264	12
Seakeeper 9/7HD through 40	188 - 264	24

7. **IF** AC voltage is not correct, **THEN TROUBLESHOOT** vessel electrical system.

NOTE:

If model has DC-powered seawater pump,
then Steps 8 through 11 are NOT APPLICABLE.

8. **REMOVE** SW PUMP leads from SW PUMP terminal.
9. **ACTIVATE** seawater override.
10. **MEASURE** voltage at SW PUMP terminal with meter in AC Volts mode.

Voltage at SW PUMP terminal: _____ **VAC**

11. **DEACTIVATE** seawater override.



*Testing SW Pump
voltage*

**WARNING:**

PERSONNEL SHOCK HAZARD EXISTS when working on live circuitry.
Seakeeper may start remotely.

12. **ENSURE** flywheel at zero RPM at display or MFD app.
13. **TURN OFF** AC breaker to Seakeeper.
14. **PERFORM** testing of motor leads per [SWI-124 - Seakeeper Motor Lead Testing](#).
15. **ENSURE** all power restored to Seakeeper.
16. **TEST** voltage at "400V DC" terminal with meter in DC Volts mode.

Voltage at "400V DC" terminal: _____ **VDC**

NOTE:

It is possible that one fault leads to other faults. These steps assume a series of faults may have occurred from one initial fault.

17. **IF** voltage at "400V DC" terminal is NOT between 390 and 400VDC **OR** motor lead testing UNSATISFACTORY,
THEN CONTACT Seakeeper Product Support Team with all data, and any photos of damage, and what type motor cable sheathing found (foil-type or metal braided) to determine next steps. [Reference [SWI-089 - Seakeeper Motor Cable Splice](#)]
18. **RE-ATTACH** all motor cable leads to their respective terminal.
19. **POSITION** MDB cover with all ten M4 screws.
20. **TORQUE** fasteners to **19 in-lbs (2.2 Nm)** to minimize moisture intrusion into MDB.
21. **TURN ON** all breakers to Seakeeper.
22. **IF** issue persists,
THEN CONTINUE to [Section 4](#).

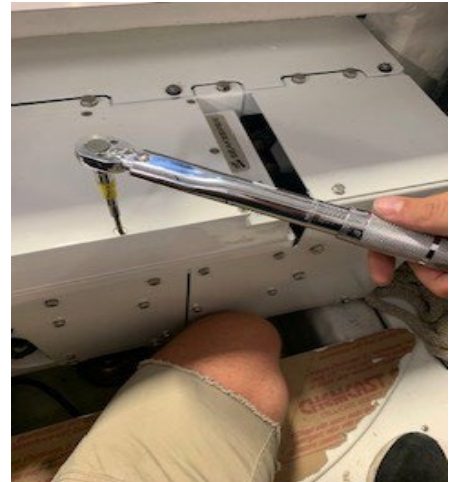

SECTION 3: DC-POWERED MODELS**WARNING:**

PERSONNEL SHOCK HAZARD EXISTS when working on live circuitry.
Seakeeper may start remotely.

1. **ENSURE** flywheel at zero RPM at display or MFD app
2. **TURN OFF** high-current DC breaker to Seakeeper.
3. **REMOVE** cover at motor drive cable contact posts and High DC current input terminals.

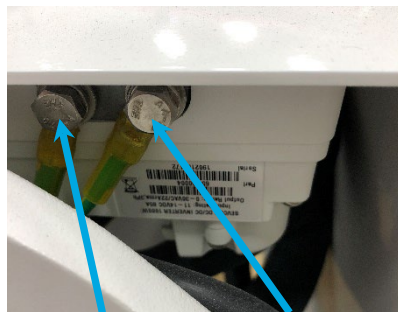

MDB Ground to foundation *Motor Frame Ground to MDB*



HIGH DC CURRENT INPUT

**SEAKEEPER 2 & 3 MDB
(BOTTOM VIEW)**

4. **INSPECT** for corrosion at contacts or damage to cables.
5. **TURN ON** high-current DC breaker to Seakeeper.
6. With multimeter, **MEASURE** High current DC voltage at INPUT terminals. **Input voltage: _____ VDC**
7. **IF** voltage measured at input was not between 11 to 15VDC, **THEN TROUBLESHOOT** vessel electrical system.
8. **TURN OFF** high current DC breaker to Seakeeper.
9. **PERFORM** testing of motor leads per [SWI-124 - Seakeeper Motor Lead Testing](#).
10. **DOCUMENT** any visible damage found with photograph.

PRODUCT SEAKEEPER SERIES MODELS

Code 85 - 93

11. **IF:**
 - motor drive cable has any phase-to-phase resistance greater than 2.0Ω,
 - any phase resistance reading is significantly higher than other two, **OR**
 - UNSATISFACTORY megohm results,

THEN CONTACT Seakeeper Product Support Team at support@seakeeper.com with all data recorded.
12. **RE-ATTACH** all motor cable leads to their respective terminal.
13. **TORQUE** terminal leads per [Torque Specifications](#) section.
14. **TURN ON** all breakers to Seakeeper.
15. **IF** issue persists,
THEN CONTINUE to [Section 4](#).

SECTION 4: COMPLETION OF TROUBLESHOOTING

	<p>WARNING:</p> <p>PERSONNEL SHOCK HAZARD EXISTS when working on live circuitry. Seakeeper may start remotely.</p>
-----------------------------------------------------------------------------------	-------------------------------------------------------------------------------------------------------------------------------

1. **IF:**
 - no damage found in wire harness
 - no damage found in connectors
 - no damage found in motor drive cable
 - no noises from enclosure when attempting to spool

THEN:

- a. **ENSURE** flywheel at zero RPM at display or MFD app.
 - b. **TURN OFF** all breakers to Seakeeper.
 - c. **REPLACE** MDB drive.
 - d. **RETURN** faulty MDB to Seakeeper.
2. **IF** alarm persists,
 - THEN:**
 - a. **COMPILE** all data from testing.
 - b. **TAKE** photo of information screen and alarm history pages.
 - c. **RECORD** video of maintenance screen while attempting to spool up Seakeeper to show RPMs and Current.
 - d. **IF** noises heard from enclosure, **THEN RECORD** video of Seakeeper attempting to spool within 3 feet (1 m) with little or no background noise.
 - e. **SUBMIT** data, photos and video to Seakeeper Product Support Team at support@seakeeper.com for review.

***** **END** *****

PRODUCT SEAKEEPER SERIES MODELS

CODE 94

To troubleshoot and repair the “DRIVE PREOPERATIONAL” alarm (Code 94).

BACKGROUND

The “Preoperational” mode is a state in which programming of the motor drive box (MDB) is allowed; the MDB will not communicate with the Seakeeper in this state. It is unexpected for a Seakeeper to display this alarm.

PRECAUTIONS

See [PRECAUTIONS](#) in Introduction section.

PROCEDURE

1. **CYCLE** low current DC power to Seakeeper by opening and then closing breaker.
2. **ALLOW** up to fifteen (15) minutes for Seakeeper to reset.
3. **ATTEMPT TO RESET** alarm at display or MFD app.
4. **IF** alarm fails to reset,
 THEN REPLACE MDB.
5. **RETURN** MDB to Seakeeper by contacting Seakeeper Product Support Team at support@seakeeper.com.

******* END *******

PRODUCT SEAKEEPER SERIES MODELS

CODE 95/96 🏠

To troubleshoot and repair the “DRIVE HARDWARE FAULT” alarm (Code 95) and the “DRIVE FAULT” alarm (Code 96).

BACKGROUND

These codes originate in the Motor Drive Box (MDB). They are reported to the Gyro Control Module (GCM) via the controller area network (CAN) when the MDB experiences an internal or general fault. The general fault is a fault developed by the manufacturer of the MDB. The internal fault was developed by Seakeeper software programming in the MDB.

Code 95 is for all hardware faults; internal communication (within the MDB) has been lost. In this event, the microcontroller can no longer control the system.

The Code 96 fault is a power frame ID fault. In this case, the microcontroller does not recognize the internal hardware configuration. The alarm occurs only sporadically; it may only happen if water intrusion occurs inside the MDB printed circuit board (PCB). Another time this may occur is during the programming of the MDB, but it would be caught quickly before returning to operation.

Issues that result in this alarm may be in the MDB and require its replacement. Troubleshooting should eliminate any material fault before replacing the MDB.

PRECAUTIONS

See [PRECAUTIONS](#) in Introduction section.

PROCEDURE

1. **IF** other codes active,
THEN TROUBLESHOOT other active codes first.

**WARNING:**

PERSONNEL SHOCK HAZARD EXISTS when working on live circuitry.
Seakeeper may start remotely.

2. **ENSURE** flywheel at zero RPM at display or MFD app.
3. **TURN OFF** all breakers to Seakeeper.
4. **ENSURE** MDB connector is securely fastened.

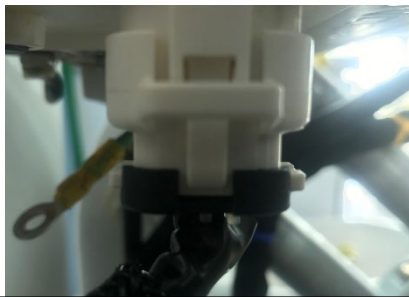

Seakeeper 2 or 3 MDB connector securely fastened.

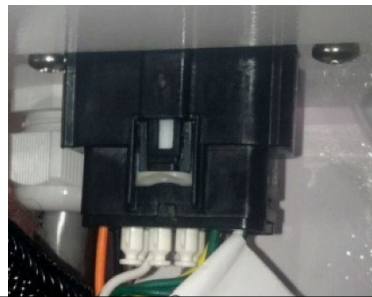

An AC-powered model's MDB connector securely fastened.

5. **ENSURE** no visible damage to wire harness near MDB drive.

PRODUCT SEAKEEPER SERIES MODELS

Code 95/96

6. **INSPECT** drive connector for loose wires or crimps or damage or corrosion:

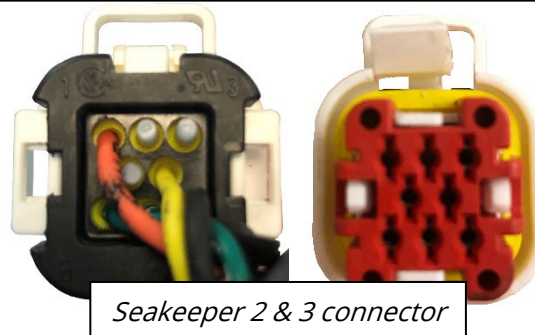
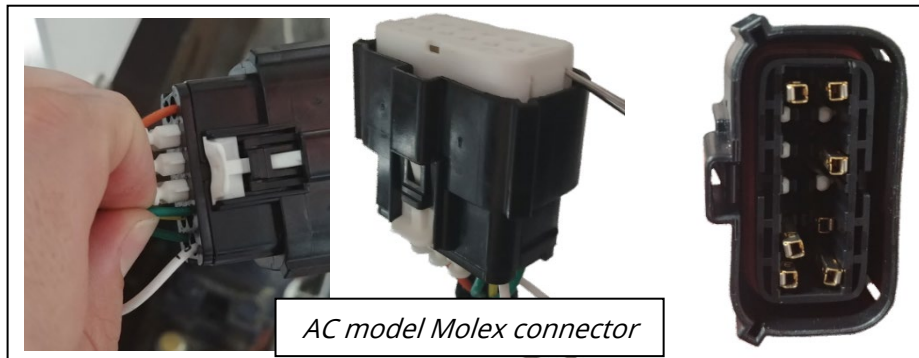

- a. **TUG** on wires from back of connector.
 - b. **REMOVE** connector face cover.
 - c. **CONFIRM** sockets and crimps are secure.
7. **IF** loose wires or crimps found in MDB connector, **THEN REPAIR** connector. [**CONTACT** Seakeeper Product Support Team at support@seakeeper.com for assistance]
8. **VERIFY** no damage to MDB case.
9. **IF** casing damage found, **THEN REPLACE** MDB.

SEAKEEPER TROUBLESHOOTING GUIDE - 106



PRODUCT SEAKEEPER SERIES MODELS

Code 95/96

10. **CYCLE** low current DC power to Seakeeper.
11. **WAIT** up to 15 minutes for Seakeeper to reset after power cycling.
12. **IF** alarm persists,
THEN SUBMIT results from all checks made to Seakeeper Product Support Team at support@seakeeper.com for review.

******* END *******

PRODUCT SEAKEEPER SERIES MODELS

CODE 98

To troubleshoot and repair the “AC MAINS LOW” alarm (Code 98).

BACKGROUND

This condition occurs only on AC-powered Seakeeper models when the Seakeeper senses a voltage lower than 80VAC for longer than two consecutive minutes. A “Notice 97 – AC Power Low” will precede this alarm to warn the operator of an abnormal voltage once the voltage drops below 80VAC. The notice will appear when the power button is first pressed to spool the Seakeeper and the voltage is below 80VAC. It will remain for two minutes and then be replaced by the “Alarm 98 – AC Mains Low” alarm. The delay is due to the delay of the vessel and operator switching from shore power to generator, or vice versa.

If attempting to spool up for longer than 10 seconds before the voltage drops low, the Seakeeper will wait two minutes before displaying the notice and another two minutes before displaying the alarm; this gives the vessel four minutes to restore proper AC voltage. At any time during the two minutes of the notice, the voltage is restored to the normal voltage range (80 to 300 VAC), the message will disappear, and no alarm history entry will be made.

Most service calls recorded by Seakeeper for this alarm result in vessel electrical issues. Occasionally, a Motor Drive Box (MDB) failure is to blame. Because of this, troubleshooting will eliminate the possibility of a vessel electrical issue first and then address the MDB fault.

REFERENCES

Applicable Seakeeper Service Drawings on [Dealer Access](#)

PRECAUTIONS

See [PRECAUTIONS](#) in Introduction section.

PROCEDURE**WARNING:**

PERSONNEL SHOCK HAZARD EXISTS when working on live circuitry.
Seakeeper may start remotely.

1. **ENSURE** Seakeeper AC breaker is turned ON.
2. **PERFORM** following inspections:
 - a. **INSPECT** AC panel breaker terminals for loose or corroded connections.
 - b. **IF** a relay is in supply power,
THEN VERIFY relay is wired correctly.
3. **ENSURE** flywheel at zero RPM at display/MFD app.
4. **IF** Service screen indicates "1234 RPM,"
THEN:

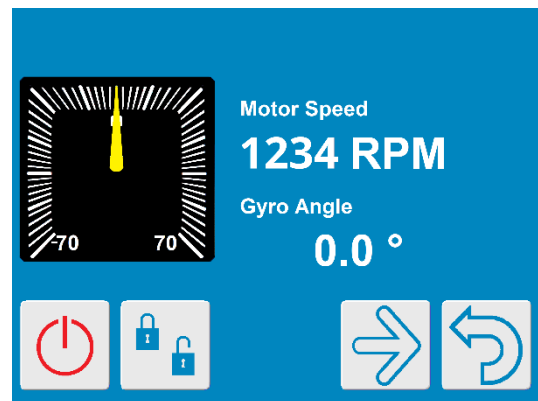
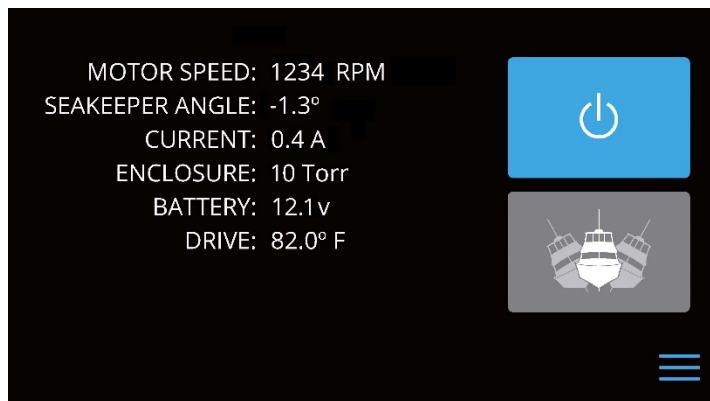

- a. **CHECK** voltage at output of breaker (80 to 300 VAC).
- b. **CHECK** voltage within any junction box in AC power cable run.
- c. **IF** voltage satisfactory,
THEN:
 - i. **REPLACE** faulty MDB.
 - ii. **RETURN** faulty MDB to Seakeeper.

**WARNING!**

SHOCK HAZARD EXISTS WHEN FLYWHEEL ROTATING
OR POWER ALIGNED TO SEAKEEPER.

5. **OPEN** MDB cover.
6. **PERFORM** following:
 - a. **VERIFY** all cable leads in proper location, crimps are satisfactory, and leads are securely fastened at terminals.

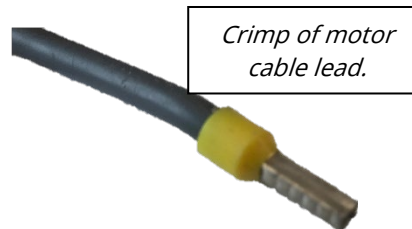

- b. **MEASURE** voltage at "AC INPUT" terminal.

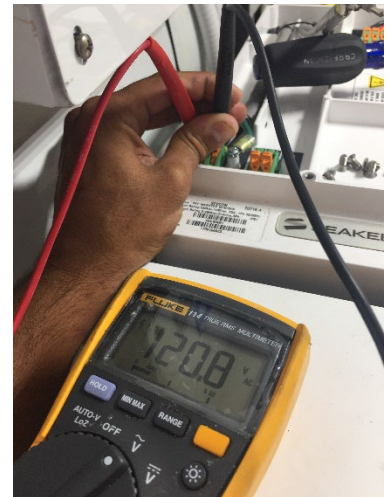
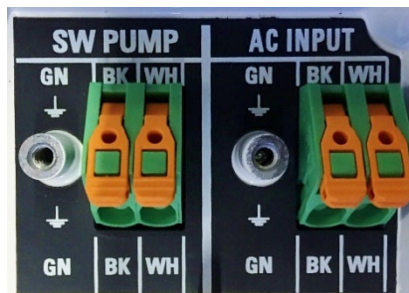

- c. **IF** voltage not between 80 and 300 VAC,
THEN TROUBLESHOOT AC power cable to Seakeeper.
 - d. **DOCUMENT** voltage and source.

For example: "221.3 VAC on Shore Power." Documentation will be used for comparison later.

PRODUCT SEAKEEPER SERIES MODELS

Code 98

Step 6 continued

- e. **CHANGE** to an alternate source customarily used for powering Seakeeper.
For example: If Step 6.d was documented with shore power, shift to a generator that would typically be used underway.
- f. **DOCUMENT** voltage and source.
- g. **START** Seakeeper to spool flywheel.
- h. **MEASURE AND RECORD** voltage at "400V DC" terminal.
- i. **IF** not between 390 and 400 VDC,
THEN REPLACE MDB.
- j. **MONITOR AND RECORD** voltages and current (from display current reading) as flywheel spools.

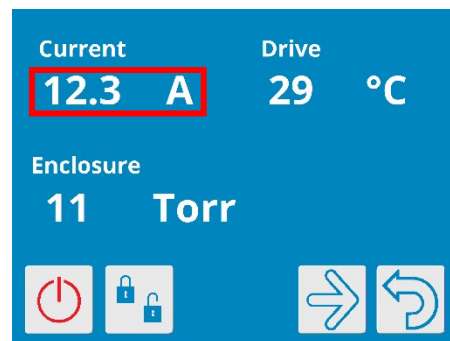
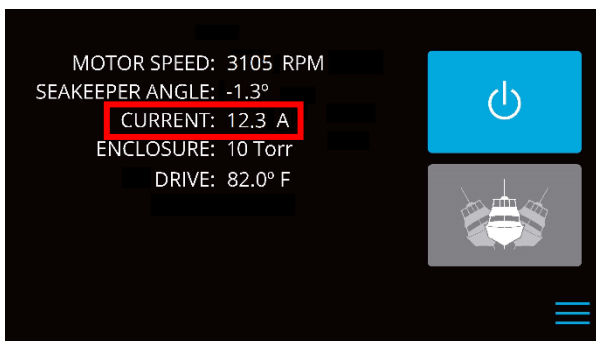
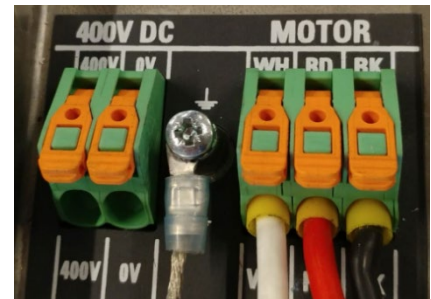

- k. During spool up, **START** large loads that would possibly lower vessel voltage (for example, engines, AC windlass, Air Conditioning) **AND MONITOR** effects on Seakeeper.
- l. **IF** a load creates alarm,
THEN DETERMINE cause for voltage drop from that load.

SEAKEEPER TROUBLESHOOTING GUIDE - 106



PRODUCT SEAKEEPER SERIES MODELS

Code 98

7. **IF** alarm persists,
THEN:
 - a. **COMPILE** all data from troubleshooting.
 - b. **NOTE** source of AC power when alarm is triggered.
 - c. **PHOTOGRAPH** display information screen.
 - d. **SUBMIT** test results data, notes, and photos to Seakeeper Product Support Team at support@seakeeper.com for review.

***** **END** *****

CODE 99-102

To troubleshoot and repair:

- “MOTOR FAULT - OVERCURRENT” alarm (Code 99)
- “DRIVE DSPPF* FAULT” alarm (Code 100)
- “DRIVE PULSING ERROR” alarm (Code 101)
- “DRIVE OP (OUTPUT) CIRCUIT” alarm (Code 102).

* Digital Signal Processor Power Frame

BACKGROUND

Code 99 is reported to the GCM from the drive and is a more generic alarm associated with the Motor Drive circuit. As with the others in this guide, it will alarm if a short exists within the motor drive cable or a fault within the MDB.

Code 100 will alarm when there is an overcurrent to the motor, sensed by the digital signal processor of the flywheel motor controller inside the MDB. Like most alarms, all four will cut power to the flywheel motor and lock the brakes upon activation. The alarm condition(s) must be cleared before resetting the Seakeeper.

Code 101 is reported to the GCM from the MDB. It is the drive’s internal alarm concerning the circuitry responsible for developing the DC voltage pulses to mimic AC power (known as pulse width modulation). The issue could lie in the power drive cables, the wire harness, or their respective connections.

Code 102 is often displayed after other faults, like Codes 99 and 100. This fault can occur due to shorting and results in the drive’s output stage shutting itself down. It can also happen if the motor leads are open due to not being inserted into the drive, a broken wire, or a damaged motor.

These codes could alarm due to a fault in the motor leads, the motor windings, or the processor circuitry. The motor drive cables are shielded (on AC-powered models); wires can be shorted to the shield, which goes to ground. The harness, too, can short, causing a failure in CAN communication or proper voltages; therefore, it will be tested for electrical integrity.

Megohm testing is performed in this guide to determine the condition of the insulation and potting of the motor drive cable and flywheel motor. Because megohmmeters vary in quality and accuracy, the guide uses a time-resistance test that eliminates some of these variables. A meter that can provide a continuous test voltage for 60 seconds is required.

SEAKEEPER TROUBLESHOOTING GUIDE - 106



PRODUCT SEAKEEPER SERIES MODELS

Code 99 - 102

REFERENCES

[SWI-093 - Molex Harness Connector](#)

[SWI-124 - Seakeeper Motor Lead Testing](#)

[SB-90504 - CAN Correction in Wire Harness](#)

PRECAUTIONS

See [PRECAUTIONS](#) in Introduction section.

PROCEDURE

SECTION 1: INITIAL CHECKS

1. **PERFORM** this procedure in its entirety (multiple failures may cause a single code) **AND RECORD** results of inspections and tests.

WARNING:

PERSONNEL SHOCK HAZARD EXISTS when working on live circuitry.
Seakeeper may start remotely.

2. **ENSURE** flywheel at zero RPM at display or MFD app.
3. **TURN OFF** all Seakeeper power breakers.
4. **VERIFY** wire harness connector at Motor Drive is fully inserted.

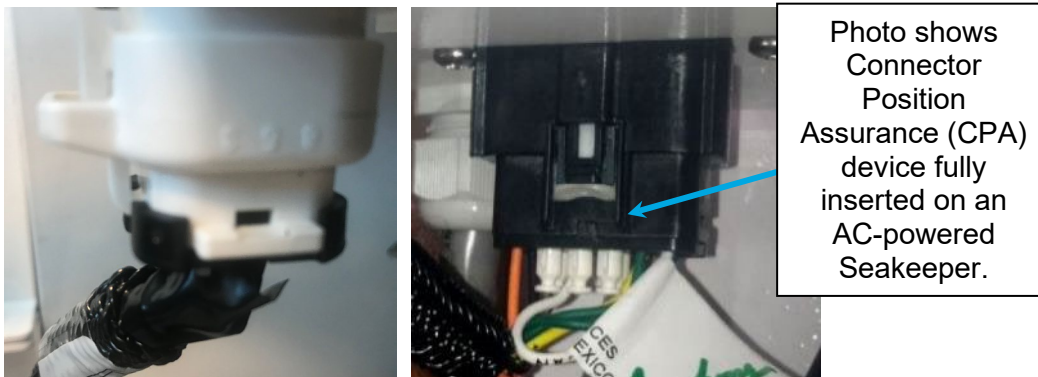

5. **VERIFY** motor terminal leads securely attached.

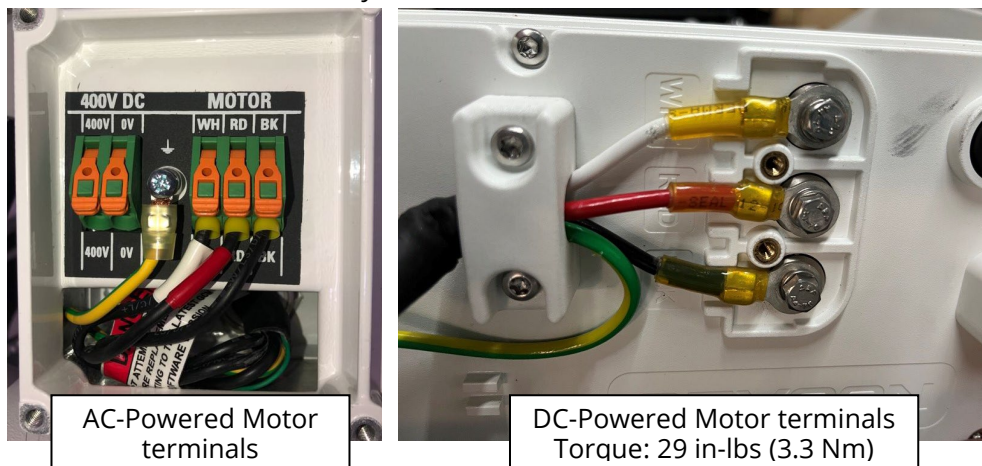

PRODUCT SEAKEEPER SERIES MODELS

Code 99 - 102

6. **THOROUGHLY INSPECT** length of motor cable (from MDB connection to enclosure feed-through).
- a. By touch and visual, **INSPECT** for fraying, signs of burning or break down of insulation along Seakeeper foundation, guide band and on enclosure to feed-through.

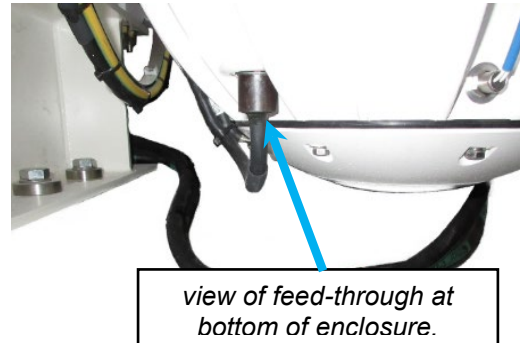
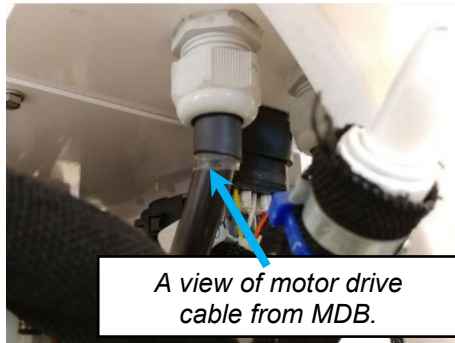

- b. **IF** damage found,
THEN:
- i. **PHOTOGRAPH** physical damage.
 - ii. **SUBMIT** photos to Seakeeper Product Support Team at support@seakeeper.com.
7. **IF** model is AC-powered,
THEN CONTINUE to [Section 2](#).
8. **IF** model is DC-powered,
THEN CONTINUE to [Section 3](#).

SECTION 2: AC-POWERED MODELS

1. With power remaining deenergized, **PERFORM** following checks on Molex connector:

- a. **DISCONNECT** MDB Molex connector.
- b. **INSPECT** connector for loose wires and crimps.
- c. **IF** loose wires or crimps found, **THEN REPAIR** connector referencing [SWI-093 - Molex Harness Connector](#). [**CONTACT** Seakeeper Product Support Team at support@seakeeper.com for assistance]
- d. **IF** any wiring appears damaged/abraded, **THEN REPLACE** wire harness.

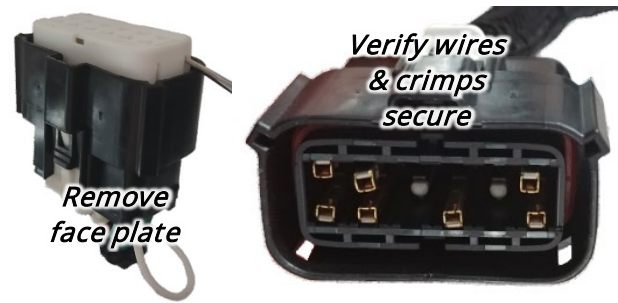

2. **IF** MDB version XXXXX-3 or older (as seen in photo), **THEN:**

- a. **IF** MDB revision 2, **THEN:**
 - i. **REPLACE** MDB.
 - ii. **CONTINUE** in procedure.
- b. **TURN OFF** AC breaker to Seakeeper.
- c. **OPEN** MDB cover.
- d. **INSPECT** for metallic wire bushing in grommet of motor power cable.
- e. **IF** bushing present, **THEN:**
 - i. **DISCONNECT** motor power wires from MDB terminal.
 - ii. **REMOVE** bushing from grommet.
 - iii. **APPLY** heat shrink shroud around cable at grommet.
 - iv. **RECONNECT** motor power cable wires to MDB terminal.

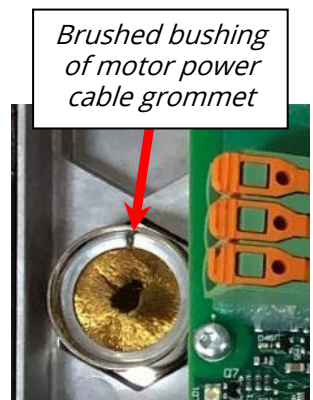
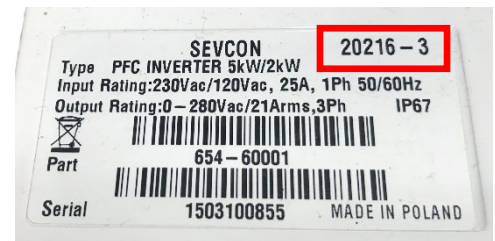

NOTE:

Intermittent opens in a wire may not be seen without manipulating the harness to duplicate movement of precession.

3. **TURN ON** DC power breaker to Seakeeper.
4. With multimeter on DC Volts, **TEST** harness MDB connector for proper DC voltage between pin **1** and pin **7** (12VDC for Seakeeper 5 and 6; 24VDC for Seakeeper 9 and up).

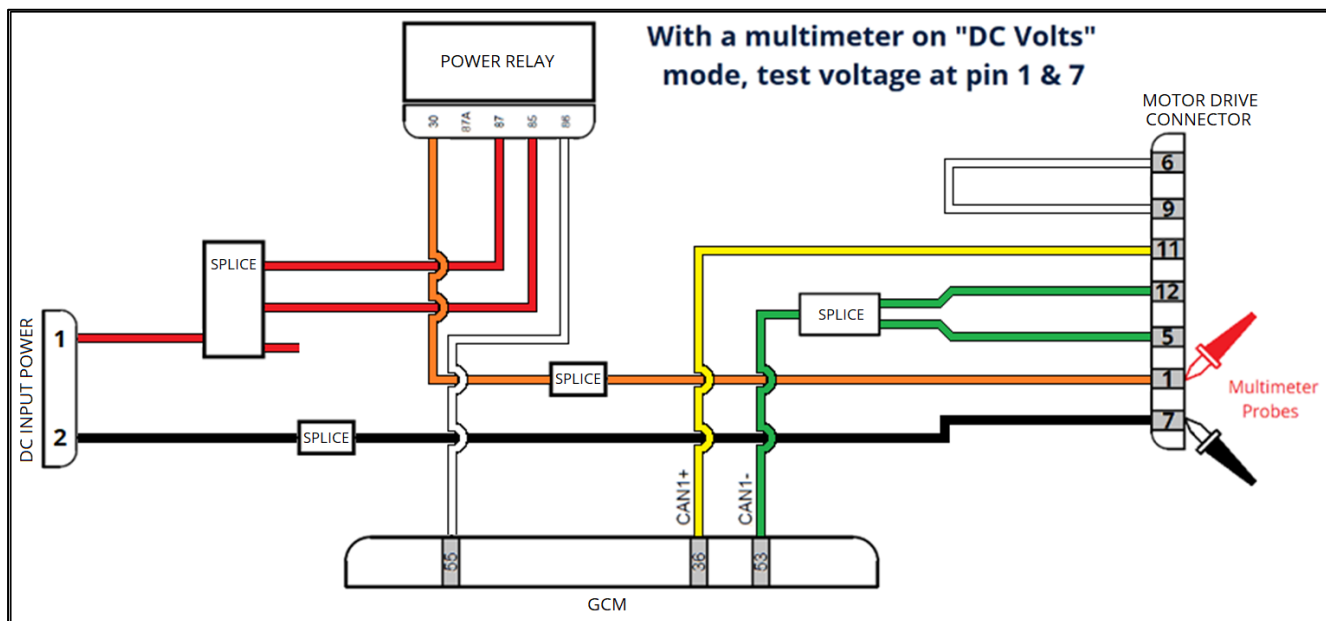

5. **UNPLUG** GCM 70-pin connector.
6. **TURN OFF** DC power breaker to Seakeeper.

7. With multimeter in Resistance mode, **CONFIRM** OPEN LOOP to ground on Molex pins **1, 5, 11** and **12** to DC Input harness connector pin **2**.
8. **IF** short was detected in Step 7 (any reading besides "OL"), **THEN REPLACE** wire harness.

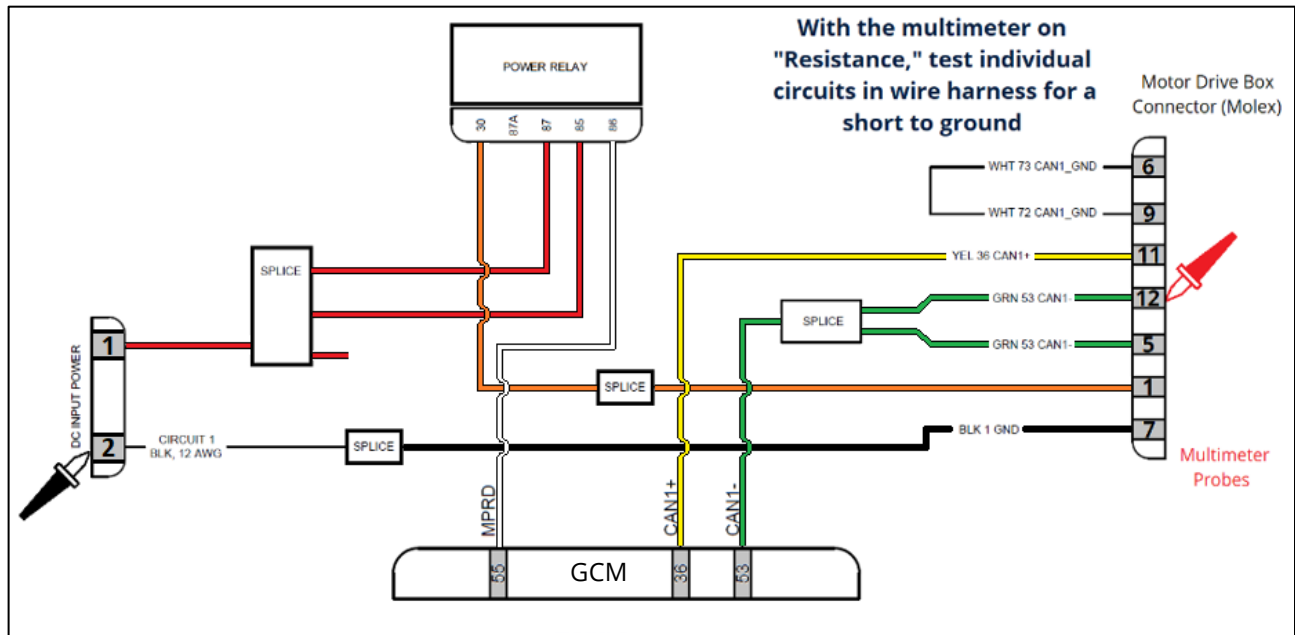

9. **IF** voltage of Step 4 (between pins 1 and 7 of MDB connector) was zero VDC, **THEN TEST** DC input for proper voltage.
 - a. **IF** input voltage is SATISFACTORY, **THEN REPLACE** main power relay.
 - b. **REPEAT** Step 4.
 - i. **IF** Step 4 still shows unsatisfactory voltage after Power Relay replacement, **THEN REPLACE** wire harness.
 - c. **IF** input voltage is UNSATISFACTORY, **THEN TROUBLESHOOT** vessel electrical system.

**WARNING:**

SHOCK HAZARD EXISTS WHEN FLYWHEEL ROTATING.

10. **ENSURE** flywheel at zero RPM at display or MFD app.
11. **TURN OFF** AC and DC breakers to Seakeeper.
12. **REMOVE** MDB cover.
13. **VERIFY** crimps at end of each motor cable lead are securely fastened **AND** making good contact in terminal.
14. **LOOSEN** MDB feed-through grommet **AND EXAMINE** motor drive cable insulation at grommet.
15. **ENSURE** interior of MDB is free of moisture.



This damaged insulation caused DSPPF Fault in this Seakeeper.





NOTE:

If Seakeeper 18/16-194-0001 or after, or Seakeeper 9-212-3388 or after, or Seakeeper 6/5-211-2771 or after, then Step 16 is NOT APPLICABLE.

16. **IF** equipped with AC Seawater Pump powered from MDB,
THEN:
- a. **REMOVE** SW Pump leads from SW PUMP terminal.
 - b. **TURN ON** AC and DC power to Seakeeper.
 - c. **ACTIVATE** seawater override.
 - d. With multimeter in AC Volts mode, **TEST** voltage at AC INPUT terminal.

TABLE 1: POWER REQUIREMENTS				
MODEL	HI CURRENT INPUT TO MDB	BREAKER/ FUSE RATING	DC INPUT	BREAKER/ FUSE RATING
Seakeeper 5 (EM) 5-0001 through 5-1049	110/230 VAC (97.2 – 132 OR 188 – 264)	30 A @ 110VAC 25A @ 230VAC	12VDC	15 A
Seakeeper 5 & 6		30 A @ 110VAC 25 A @ 230VAC	12VDC	15 A
Seakeeper 9/7HD	230 VAC (188 – 264)	20 A	24VDC	10 A
Seakeeper 16/12HD Up to 16/12HD-193-0912		20 A	24VDC	10 A
Seakeeper 18/16/12HD*		25 or 30 A	24VDC	10 A**
Seakeeper 26/20HD		20 A	24VDC	10 A
Seakeeper 35/30HD		30 A	24VDC	15 A
Seakeeper 40			24VDC	15 A

* Seakeeper 16/12HD after 16/12HD-194-0001 ** Two relays exist on harness: 1 power & 1 SW Pump

- e. **IF** not at proper voltage,
THEN TROUBLESHOOT vessel's electrical system.

PRODUCT SEAKEEPER SERIES MODELS

Code 99 - 102

Section 2, Step 16 continued

- f. **VERIFY** AC voltage at SW PUMP terminal same as AC INPUT terminal voltage.
 - i. **IF** voltage not same at SW PUMP terminal, **THEN REPLACE** MDB.
- g. **DEACTIVATE** seawater override.
- h. At display, **PRESS** RUN button to begin spooling not to exceed 100 RPM.
 - i. **IF** alarm returned, **THEN CONTINUE** with this step.
 - ii. **IF** alarm did NOT return, **THEN:**
 - a. **ENSURE** Seakeeper at zero RPM.
 - b. **RECONNECT** SW Pump leads
 - iii. **PRESS** RUN button.
 - iv. **IF** alarm returns to display with SW Pump leads connected, **THEN INSPECT** leads of SW Pump power cable for short or damage.
17. **ENSURE** Seakeeper flywheel at zero RPM.
18. **IF** Step 16 skipped, **THEN PRESS** RUN button on MFD app / display.

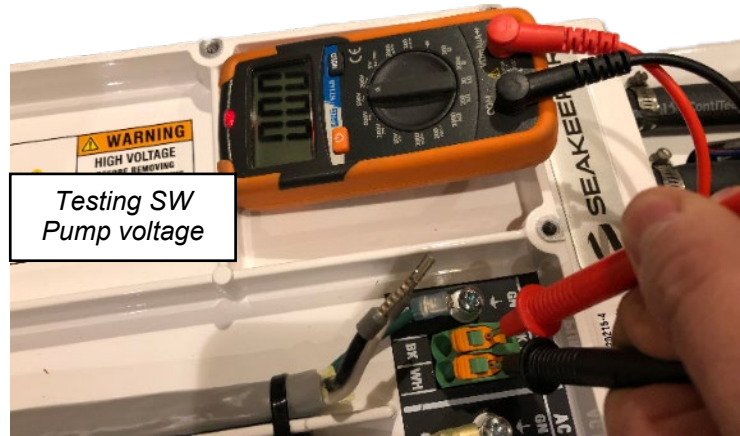

PRODUCT SEAKEEPER SERIES MODELS

Code 99 - 102

19. **TEST** voltage at "400V DC" terminal.
 - a. **IF** voltage at "400V DC" terminal is NOT between 390 and 400VDC, **THEN REPLACE** MDB.
20. **STOP** Seakeeper at display/MFD app.
21. **TURN OFF** AC power breaker to Seakeeper.
22. **PERFORM** testing of motor leads per [SWI-124 - Seakeeper Motor Lead Testing](#).
23. **DOCUMENT** any physical damage with photograph.

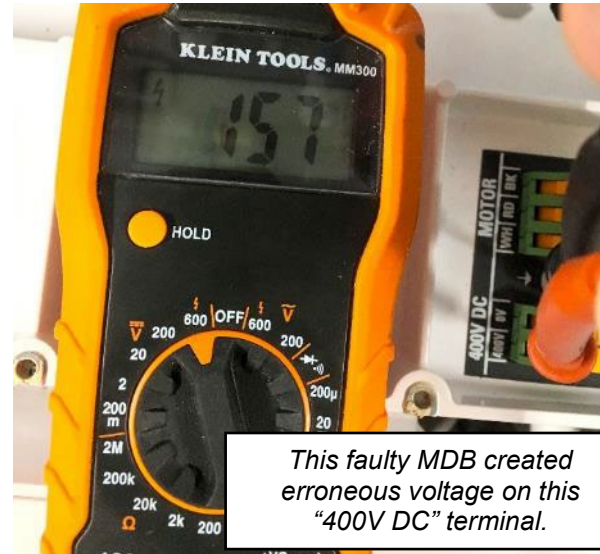

This faulty MDB created erroneous voltage on this "400V DC" terminal.

PRODUCT SEAKEEPER SERIES MODELS

Code 99 - 102

24. **IF:**

- motor drive cable has any phase-to-phase resistance greater than 2.0Ω ,
- any phase resistance is 0.5Ω higher than other two, **OR**
- QUESTIONABLE megohm results,

THEN:

- a. **COMPLETE** form [SF-90683 – Pre-FRB Swap Checklist](#).
 - b. **SUBMIT** form, all data recorded, and type of motor power cable sheathing found (foil-type or braided metal) to support@seakeeper.com.
25. **RE-ATTACH** all motor cable leads to their respective terminal.
26. **INSTALL** MDB cover.
27. **TORQUE** ten M4 screws of cover to **19 in-lbs (2.2 Nm)** to prevent moisture intrusion.
28. **TURN ON** all Seakeeper breakers.
29. **IF** issue persists,
THEN PROCEED to [Section 4](#).



SECTION 3: DC-POWERED MODELS**WARNING:**

PERSONNEL SHOCK HAZARD EXISTS when working on live circuitry.
Seakeeper may start remotely.

1. **PLACE** Seakeeper in safe condition as follows:
 - a. **ENSURE** flywheel at zero RPM at display or MFD app.
 - b. **TURN OFF** high current DC breaker to Seakeeper.
 - c. **ACCESS** MDB.
2. **REMOVE** cover at motor drive and battery input terminals (highlighted below).

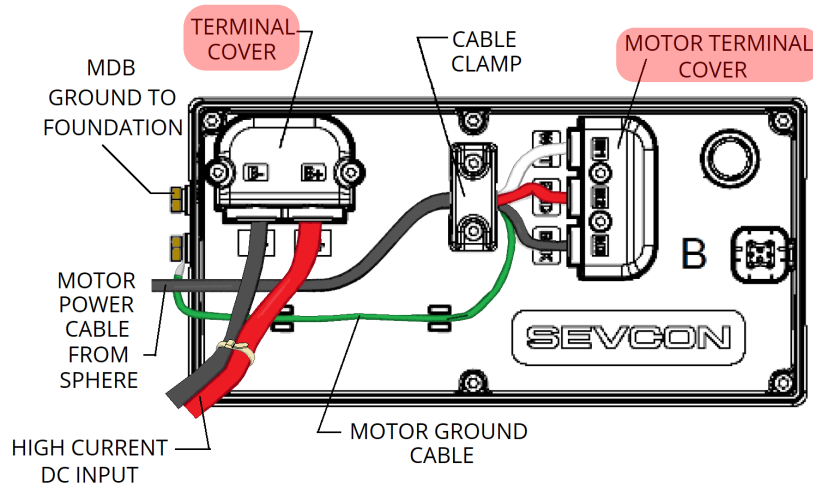

3. **INSPECT** for following:
 - a. corrosion at terminals
 - b. loose or damaged wires or crimps
 - c. discoloration from overheating
4. **DISCONNECT AND ELECTRICALLY ISOLATE** motor drive cable leads and motor ground cable from side of MDB.

PRODUCT SEAKEEPER SERIES MODELS

Code 99 - 102

5. With multimeter in "DC Volts," **TEST** for 12VDC (10.0 – 15.0VDC) at low-current DC input.
 - a. **IF** voltage NOT between 10.0 and 15.0VDC, **THEN TROUBLESHOOT** vessel electrical.
6. **TEST** for 12VDC (10.0 – 15.0VDC) between sockets **1** and **8** of MDB connector, as shown in illustration below.

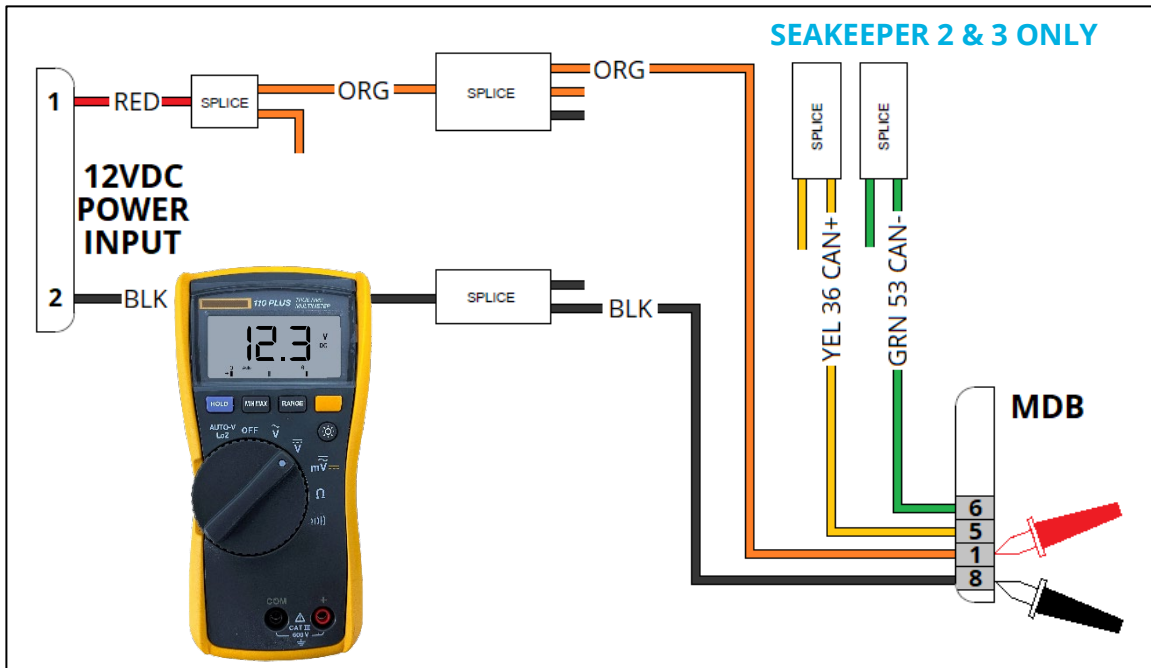

- a. **IF** voltage at sockets **1** and **8** is NOT between 10.0 and 15.0VDC **AND** voltage in Step 5 was SATISFACTORY, **THEN REPLACE** wire harness.

NOTE:

Intermittent opens in a wire may not be seen without manipulating the harness to duplicate movement of operation.

7. With multimeter in resistance mode, **VERIFY** NO short to ground on MDB pins **1, 5** and **6** to pin **2** of DC INPUT connector.

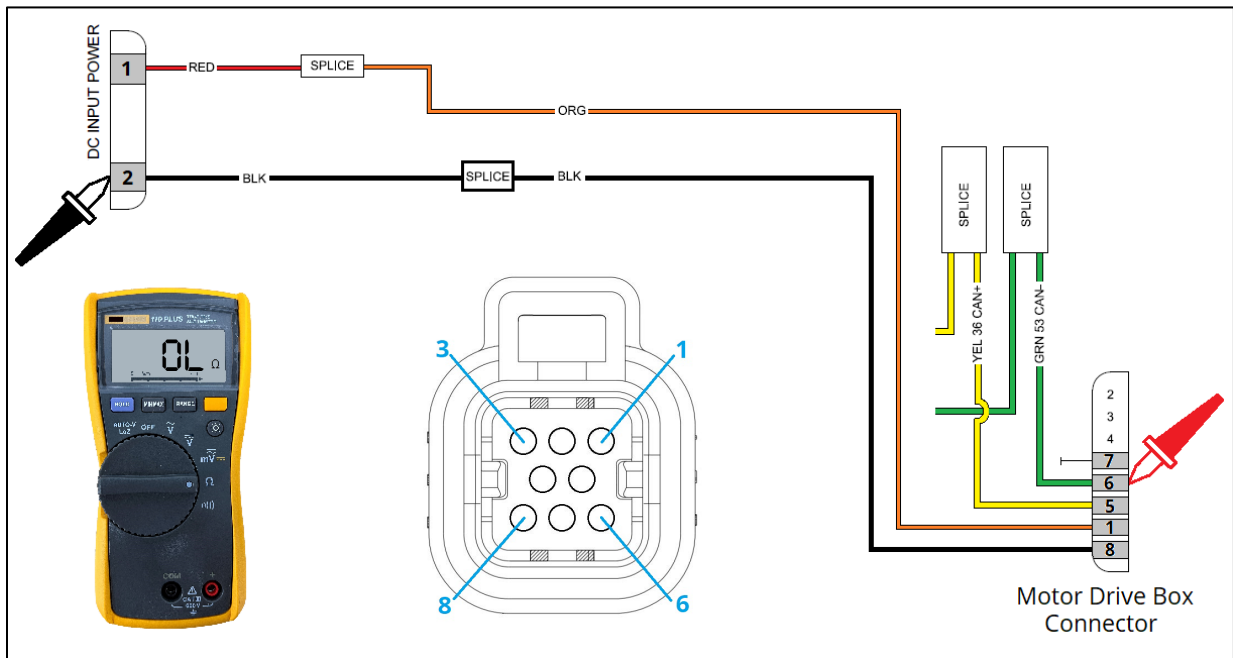

8. **IF** short to ground is discovered (Less than OL), **THEN REPLACE** wire harness.
9. **PERFORM** testing of motor leads per [SWI-124 - Seakeeper Motor Lead Testing](#).
10. **DOCUMENT** any visible damage found with photograph.

PRODUCT SEAKEEPER SERIES MODELS

Code 99 - 102

11. **IF:**

- motor drive cable has any phase-to-phase resistance greater than 2.0Ω ,
- any phase resistance is 0.5Ω higher than other two, **OR**
- QUESTIONABLE megohm results,

THEN SUBMIT all data recorded to support@seakeeper.com.**WARNING:**

SHOCK HAZARD EXISTS BECAUSE OF CAPACITANCE FROM MEGOHM TESTING.

12. **RE-ATTACH** all motor cable leads to their respective terminal.
13. **TORQUE** terminal leads per [Torque Specifications](#) section.
14. **RE-ATTACH** covers at motor drive and battery terminals on MDB.
15. **ENERGIZE** all power to Seakeeper.
16. **IF** issue persists,
THEN CONTINUE to [Section 4](#).

SECTION 4: COMPLETION OF TROUBLESHOOTING**NOTE:**

Completing SF-90683 will minimize time and resources should bearing or sphere replacement be required.

1. **IF** no damage found in wire harness, motor drive cable, or connectors, **THEN:**
 - a. **COMPLETE** as much information on [SF-90683 – Pre-FRB Swap Checklist](#) as possible.
 - b. **RECORD** one minute video at display attempting to spool Seakeeper.
 - i. **SHOW** service screen(s) during video to display RPM and Current.

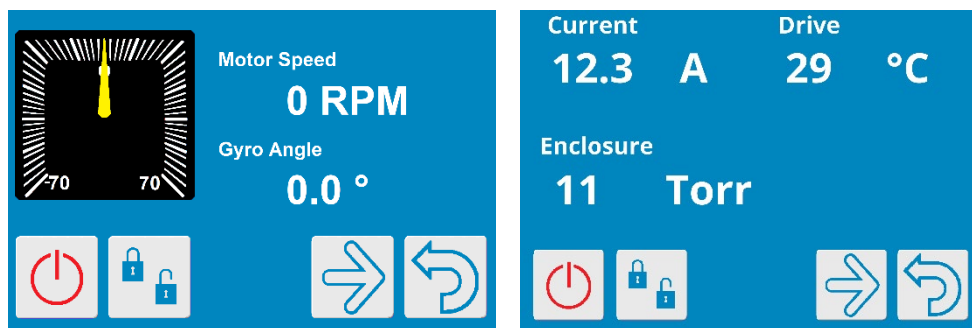
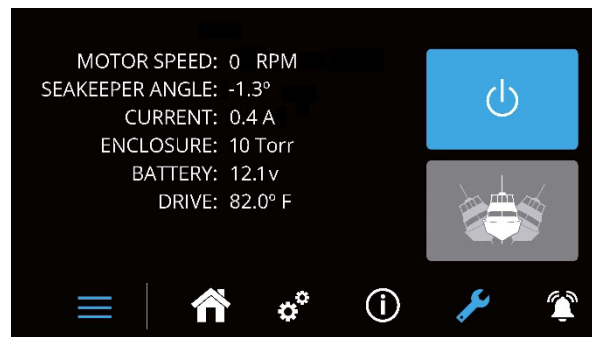

- c. **RECORD** one minute video within one yard (one meter) of Seakeeper upon start of spool up with minimal background noise.
- d. **SUBMIT** all test results, data, and recordings to Seakeeper Product Support Team at support@seakeeper.com for review.

***** **END** *****

PRODUCT SEAKEEPER SERIES MODELS

CODE 103

To troubleshoot and repair the “DRIVE SENSORLESS [Start Fault]” alarm (Code 103).

BACKGROUND

This alarm condition is reported to the Gyro Control Module (GCM) by the Motor Drive Box (MDB) when an internal fault signal is generated in the speed-sensing circuitry of the MDB. The term “sensorless” indicates that Seakeeper MDBs do not use a Hall Sensor to detect motor speed but use a characteristic in the motor supply cable called “Back EMF” to determine motor speed. When this circuit senses an issue, it creates this fault code to stop the Seakeeper to prevent damage.

In the few cases where this code has appeared, the fault has been in the enclosure internal components or vacuum. A close examination of the alarm history can guide a technician on the path to issue resolution and determine preceding and later codes that were posted to the history. In all cases of this alarm, there have been other associated codes that had been recorded.

Record all readings through phone pictures or paper records to better determine the correct course of action. When contacting the Seakeeper Product Support Team for resolution, these findings will be vital in determining the best steps for the customer.

Megohm testing is performed in this guide to determine the condition of the insulation and potting of the motor drive cable and flywheel motor. Because megohmmeters vary in quality and accuracy, the guide uses a time-resistance test that eliminates some of these variables. A meter that can provide a continuous test voltage for 60 seconds is required.

REFERENCES

[SWI-124 - Seakeeper Motor Lead Testing](#)

PRECAUTIONS

See [PRECAUTIONS](#) in Introduction section.

PROCEDURE:**SECTION 1: INITIAL CHECKS**

1. **PERFORM** this procedure in its entirety (multiple failures may cause a single code).
2. **RECORD** all inspection and test results.

**WARNING:**

PERSONNEL SHOCK HAZARD EXISTS when working on live circuitry.
Seakeeper may start remotely.

3. **ENSURE** flywheel at zero RPM at display or MFD app.
4. **TURN OFF** all breakers to Seakeeper.
5. **VERIFY** MDB harness connector is securely fastened.
6. **ENSURE** no visible damage to wire harness near MDB.
 - a. **IF** damage found,
THEN REPLACE wire harness.
7. **THOROUGHLY INSPECT** length of motor cable (from MDB connection to enclosure feed-through).
 - a. **LOOK** for any fraying, signs of burning or break down of insulation of cable along Seakeeper foundation, guide band and on enclosure up to feed-through.
 - b. **IF** damage found,
THEN SUBMIT photo of damage to support@seakeeper.com.
8. **IF** model is an AC-powered Seakeeper,
THEN CONTINUE to [Section 2](#).
9. **IF** model is a DC-powered Seakeeper,
THEN CONTINUE to [Section 3](#).

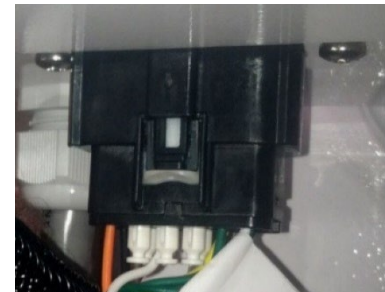

An AC-powered model's MDB connector securely fastened.

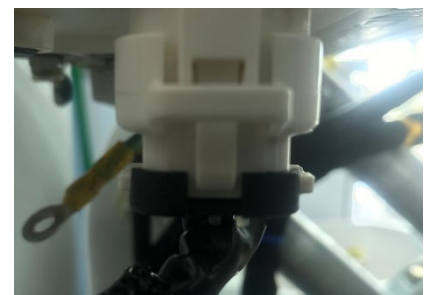

A DC-powered model's MDB connector securely fastened.

SECTION 2: AC-POWERED MODELS**WARNING:**

PERSONNEL SHOCK HAZARD EXISTS when working on live circuitry.
Seakeeper may start remotely.

1. **ENSURE** AC power breaker to Seakeeper is OFF.
2. **REMOVE** MDB cover to expose MOTOR lead connections.
3. **INSPECT** crimps at end of each motor cable lead are securely fastened in terminal with orange tabs down and locked.
4. **TURN OFF** AC power breaker to Seakeeper.
5. **PERFORM** testing of motor leads per [SWI-124 - Seakeeper Motor Lead Testing](#).
6. **IF:**
 - motor drive cable has any phase-to-phase resistance greater than 2.0Ω,
 - any phase resistance is 0.5Ω different from other two, **OR**
 - QUESTIONABLE results from megohm tests,

THEN:

 - a. **COMPLETE** form [SF-90683 – Pre-FRB Swap Checklist](#).
 - b. **SUBMIT** form, all data recorded, and type motor cable sheathing found (foil-type or metal braided) to Seakeeper Product Support Team at support@seakeeper.com.
7. **RE-ATTACH** all motor cable leads to their respective terminal.
8. **TURN ON** all breakers to Seakeeper.
9. **START** Seakeeper spooling from display/MFD app.
10. **IF** AC-powered seawater pump
THEN TEST for AC input voltage at SW PUMP terminal.



PRODUCT SEAKEEPER SERIES MODELS

Code 103

11. **TEST** voltage at “400V DC” terminal.
 - a. **IF** voltage at “400V DC” terminal is NOT between 390 and 400VDC **OR** AC voltage was improper at SW PUMP terminal, **THEN REPLACE** MDB per [SWI-094](#).
12. At display, **STOP** Seakeeper spooling.
13. **DOCUMENT** any visible damage found with a photograph.
14. **INSTALL** MDB cover.
15. **TORQUE** ten M4 Phillips head screws to **19 in-lbs (2.2 Nm)**.
16. **TURN ON** all breakers to Seakeeper.
17. **IF** issue persists, **THEN CONTINUE** to [Section 4](#).

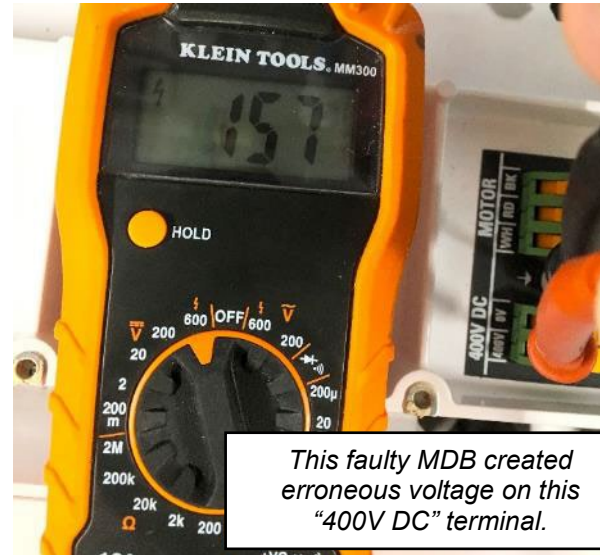

This faulty MDB created erroneous voltage on this “400V DC” terminal.

SECTION 3: DC-POWERED MODELS

All Seakeeper motor drives produce a pulse width modulated 3-phase output to the flywheel motor. The DC-powered models use a much lower voltage (48VDC nominally versus 400VDC, in AC-powered models) and it is impractical to measure its voltage with a voltmeter. This check is omitted in the troubleshooting of the Seakeeper 2 & 3.



WARNING:

PERSONNEL SHOCK HAZARD EXISTS when working on live circuitry.
Seakeeper may start remotely.

1. **ENSURE** flywheel at zero RPM at display or MFD app.
2. **TURN OFF** all power breakers to Seakeeper.
3. **REMOVE** covers at motor drive and battery terminals (highlighted below).

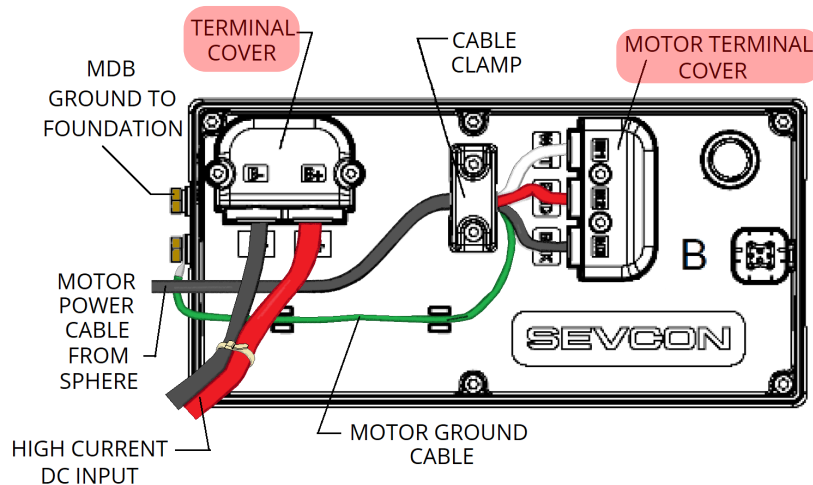

4. **INSPECT** for severe corrosion at contacts or damage to cables.
5. **PERFORM** testing of motor leads per [SWI-124 - Seakeeper Motor Lead Testing](#).
6. **DOCUMENT** any visible damage found with a photograph.

PRODUCT SEAKEEPER SERIES MODELS

Code 103

7. **IF**

- motor drive cable has any phase-to-phase resistance greater than 2.0Ω ,
- any phase resistance is 0.5Ω higher than other two, **OR**
- QUESTIONABLE megohm results,

THEN SUBMIT all data recorded to support@seakeeper.com.

**WARNING:**

SHOCK HAZARD EXISTS BECAUSE OF CAPACITANCE FROM
MEGOHM TESTING.

8. **RE-ATTACH** all motor cable leads to their respective terminal.
9. **TORQUE** terminal leads per [Torque Specifications](#) section.
10. **INSTALL** cover at motor drive cable contact posts and High DC current input terminals.
11. **TURN ON** all power breakers to Seakeeper.
12. **IF** issue persists,
THEN CONTINUE to [Section 4](#).

SEAKEEPER TROUBLESHOOTING GUIDE - 106

PRODUCT SEAKEEPER SERIES MODELS

Code 103

SECTION 4: COMPLETION OF TROUBLESHOOTING

1. **IF** no damage found in wire harness, motor drive cable, or connectors,
THEN:
 - a. **RECORD** one minute video at display attempting to spool Seakeeper.
 - i. **SHOW** service screen(s) during video to display RPM and Current.

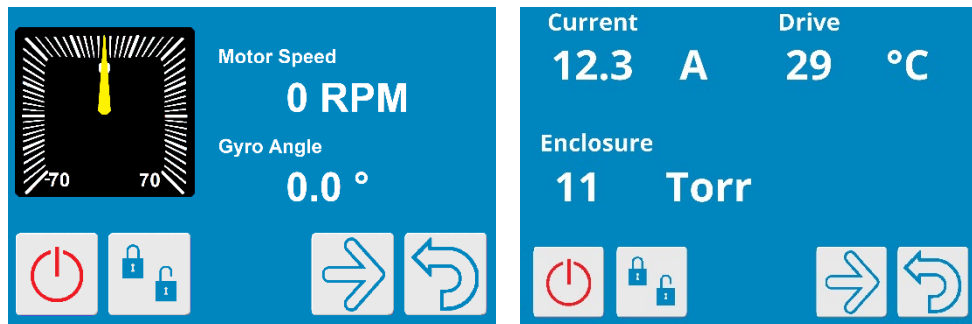
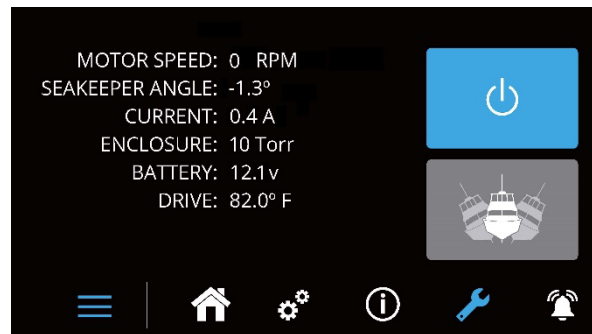

- b. **RECORD** one minute video within one yard (one meter) of Seakeeper upon start of spool up with minimal background noise.
- c. **SUBMIT** all test results data and recordings to Seakeeper Product Support Team at support@seakeeper.com for review.

******* END *******

PRODUCT SEAKEEPER SERIES MODELS

CODE 107-110/132/252

To troubleshoot and repair:

- "DISPLAY INCOMPATIBLE" alarm (Code 107)
- "DRIVE SOFTWARE INCOMPATIBLE" alarm (Code 108)
- "DRIVE SOFTWARE MODEL INCOMPATIBLE" alarm (Code 109)
- "IMU SOFTWARE INCOMPATIBLE" alarm (Code 110)
- "CONNECTBOX SOFTWARE INCOMPATIBLE" (Code 132)
- "INCOMPATIBLE GCM" alarm (Code 252)

BACKGROUND

All incompatibility alarms, except for Code 252, result from the Seakeeper's Gyro Control Module (GCM) receiving CAN messaging from a device identifying itself to have a hardware or software version that will not function with the current GCM software. The issue could be due to the device's incorrect hardware or software or the GCM itself.

The display sets code 252, identifying the GCM as having incorrect software for the display's current software. The issue could be due to incorrect GCM or Display software. Incompatibility could occur if a display programmed for an "SK-Series" model is connected to an "M-Series" Seakeeper. It could also happen if the GCM software is older or the display is connected to the vessel NMEA backbone.

IMUs (Inertia Measurement Units) cannot be programmed; their program is installed during manufacturing. An IMU must be replaced with the same generation of IMU as the original (See insert photos). If Seakeeper is equipped with an IMU-1, contact Seakeeper Product Support Team before replacing.



*1st Generation IMU
It will appear on info
screen as "IMU: 1.0X"*



*2nd Generation IMU
It will appear on info
screen as "IMU: 2.X"*

REFERENCES

[SWI-118 - Service Tool Application](#)

[TB-90555 - Display Software Compatibility](#)

PRECAUTIONS

See [PRECAUTIONS](#) in Introduction section.

PROCEDURE

1. **CHECK** information screen software versions are populated with software numbers.

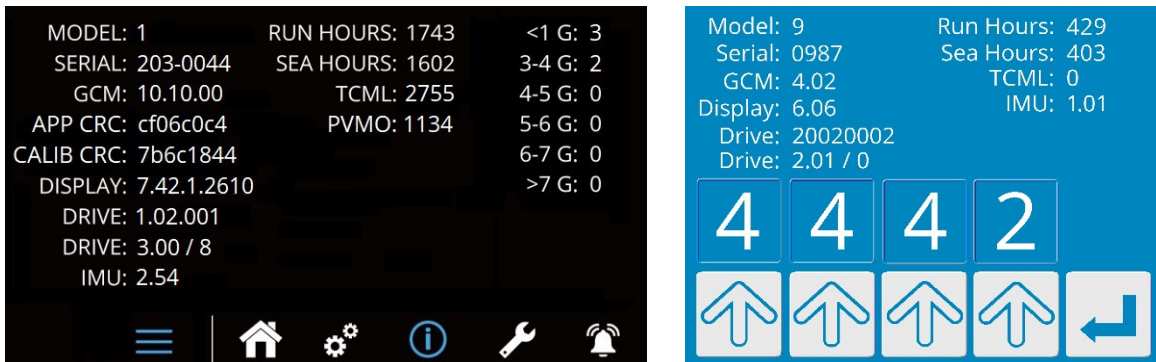

NOTE:

If Seakeeper has two displays, **BOTH** must have same software to work properly or "Display Incompatibility" fault will appear.

2. **IF** second display installed, **THEN VERIFY** both displays' software matches.



WARNING:

PERSONNEL SHOCK HAZARD EXISTS when working on live circuitry.
Seakeeper may start remotely.

3. **PLACE** Seakeeper in safe condition as follows:
 - a. **ENSURE** flywheel at zero RPM at display or MFD app.
 - b. **TURN OFF** all breakers to Seakeeper.

4. **CHECK** harness GCM, harness MDB and display/ConnectBox connections are made securely.

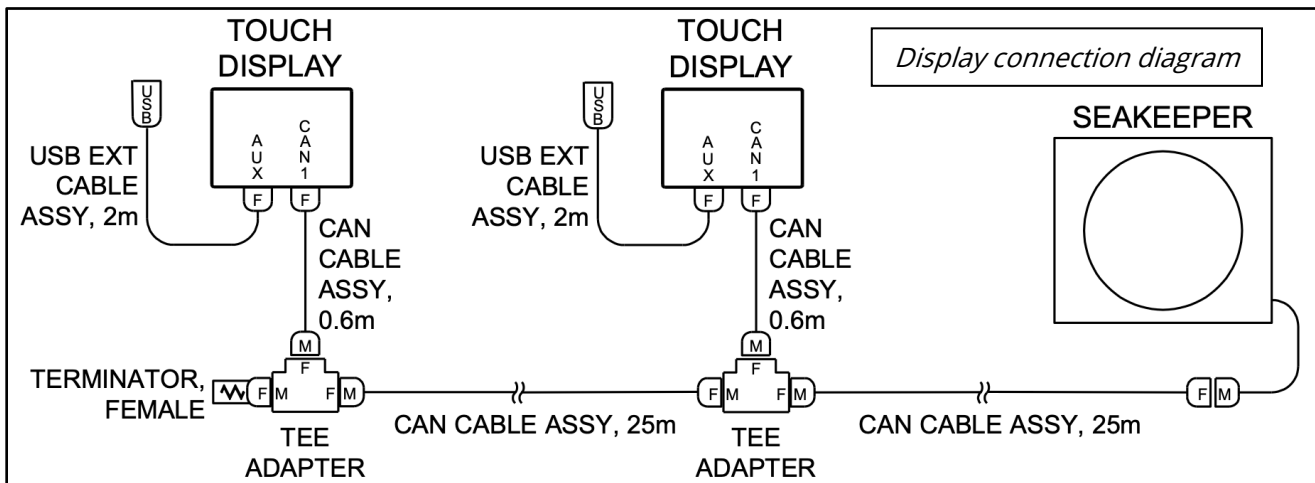

5. **IF** GCM has 11.XXX software version AND 5" Touch Display, **THEN UPDATE** display software to version 7.41.1.2586 or later.
6. **IF** GCM has 10.XX software or later versions AND 3.5 inch display, **THEN UPDATE** display software to version 6.09.
7. **IF** display software version is older than most recent release, **THEN UPDATE** display software to clear Code 107, *Display Software Incompatibility*.
8. **IF** Code 107 and all software versions populated and display software update attempted without clearing alarm, **THEN REPLACE** display with new display **AND UPDATE** display software.

The screenshot shows two panels of software information. The left panel (Model: 9) lists: Run Hours: 429, Serial: 0000, Sea Hours: 403, GCM: 4.02, TCML: 0, Display: 6.06, IMU: 1.01. Two drive entries are highlighted with red boxes: "Drive: 20020002" and "Drive: 2.01 / 0". A callout box points to these, stating: "This is MDB software version (Code 108)". Below it, another callout box states: "This file is known as a 'dcf file' for MDB (Code 109)". The right panel (MODEL: 3) lists: RUN HOURS: 1743, SERIAL: 191-1000, SEA HOURS: 1602, GCM: 10.71, TCML: 23000, DISPLAY: 7.30.1.1283. Two drive entries are highlighted with red boxes: "DRIVE: SN014235" and "DRIVE: 2.01/2". A callout box points to these, stating: "This is MDB software version (Code 108)". At the bottom, a note reads: "Versions listed are for example only. The Seakeeper on which you are working may be different."

PRODUCT SEAKEEPER SERIES MODELS

Code 107 – 110/132/252

9. **IF** component software (MDB, IMU or GCM) is found incompatible, **THEN REPLACE** applicable component as follows:
- a. **IF** Code 108 or Code 109, **THEN REPLACE** MDB.
 - b. **IF** Code 110, **THEN REPLACE** IMU.



Revision 1 IMU
 - c. **IF** code 252 (despite alarm clearing by cycling power), **THEN VERIFY** display cable does **NOT** run near other higher current carrying cables or devices.
 - d. **IF** code 252 **AND** 3.5" display is fitted, **THEN PERFORM** following:
 - i. **INSPECT** cable at back of display for any connection to display cable "SHIP MONITOR" pigtail.

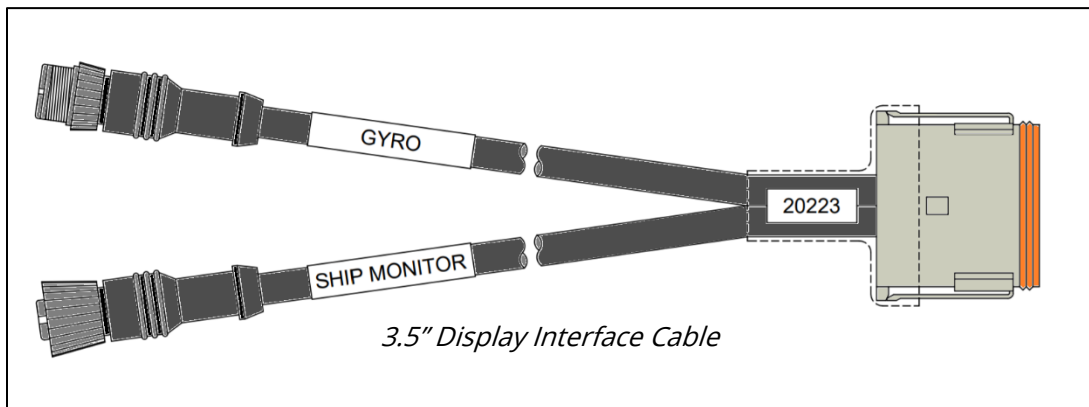

- ii. **IF** connection is found on ship monitor cable, **THEN ENSURE** it is ONLY connected to a ship's monitor network (NOT gyro or an NMEA network).
- iii. **IF** code 252 clears, **THEN LEAVE DISCONNECTED.**
- iv. **CONTACT** Seakeeper Product Support Team at support@seakeeper.com to ensure GCM software is correct for current component software setup.

SEAKEEPER TROUBLESHOOTING GUIDE - 106

PRODUCT SEAKEEPER SERIES MODELS

Code 107 – 110/132/252

Step 9 continued

- e. **IF** code 252 and 5" Touch Display, **THEN PERFORM** following:
- i. **ENSURE** cable connections are correct according to photo.
 - ii. **CONTACT** Seakeeper Product Support Team to ensure GCM software is correct for current component software setup.
10. **SAVE AND RETURN** replaced hardware component(s).
11. **TURN ON** all power breakers to Seakeeper.
12. **IF** alarm persists, **THEN CONTACT** Seakeeper Product Support Team at support@seakeeper.com with notes of all actions taken, photos of display information screen and alarm history pages for review.

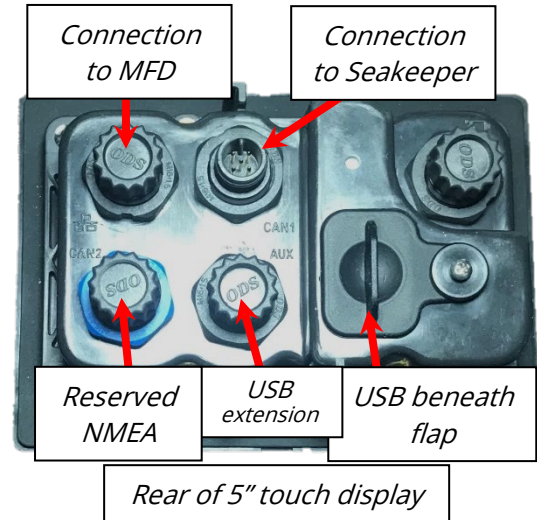
***** **END** *****

PRODUCT SEAKEEPER SERIES MODELS

CODE 111/112 & 167/168

To troubleshoot and repair:

- “DC INPUT VOLTAGE LOW [SPEED LOSS DURING OPERATION]” (Code 111)
- “DC INPUT VOLTAGE LOW [SLOW SPOOL UP]” (Code 112)
- “HIGH CURRENT DC VOLTAGE LOW” (Code 167)
- “HIGH CURRENT DC VOLTAGE HIGH” (Code 168)

BACKGROUND

The DC-powered Seakeeper 2 and 3 have been programmed to adjust power consumption as voltage drops below 11.1VDC to prevent the battery bank from depleting while supporting Seakeeper operation. The Seakeeper lowers speed until RPMs have reached 67% of the target speed. At this lower RPM, the Seakeeper will produce Code 111 to prevent further depletion of the battery bank. If the Seakeeper were in the process of spooling up, the code produced would be code 112 instead. It is activated when the Gyro Control Module (GCM) senses less than 600 watts of draw and a low DC input voltage. If incoming DC voltage drops below 10 volts, Notice 167 (DC Mains Voltage Low [2nd Stage]) will be displayed. Code 41 (DC Power In Low) will appear around the same voltage. See [Attachment 2, Voltage Alarm Thresholds](#), for more information.

The most likely cause for this alarm is the actual circumstances of a low battery voltage during the operation or start-up of the Seakeeper. The DC power supply may need to be checked. Though a battery’s voltage and specific gravity are within specification, it may still be incapable of operating correctly due to a severe loss of capacity resulting from sulfation, grid corrosion, or active material shedding. A battery load test could reveal a poor battery capacity in this event.

Should high current voltage rise above normal ranges, a Code 168 is possible. The Seakeeper 2 & 3 models will alarm near 16VDC.

The Motor Drive Box (MDB) of the Seakeeper may erroneously sense an improper voltage and produce the code. This eventuality is addressed as well.

REFERENCES

[90377 - Seakeeper 3 Cable Block Diagram](#)

[90470 - Seakeeper 2 Cable Block Diagram](#)

PRECAUTIONS

See [PRECAUTIONS](#) in Introduction section.

PROCEDURE

1. **THOROUGHLY INSPECT** Seakeeper electrical installation:
 - a. **CONFIRM** supply battery voltage per [Attachment 2](#) table.
 - b. **INSPECT** Seakeeper Battery Isolator and breakers for tight terminal connections, no wire damage, and no excessive corrosion.
 - i. **IF** remote battery switch (RBS) is used in place of isolator switch, **THEN REFER** to diagram below for alignment of RBS.

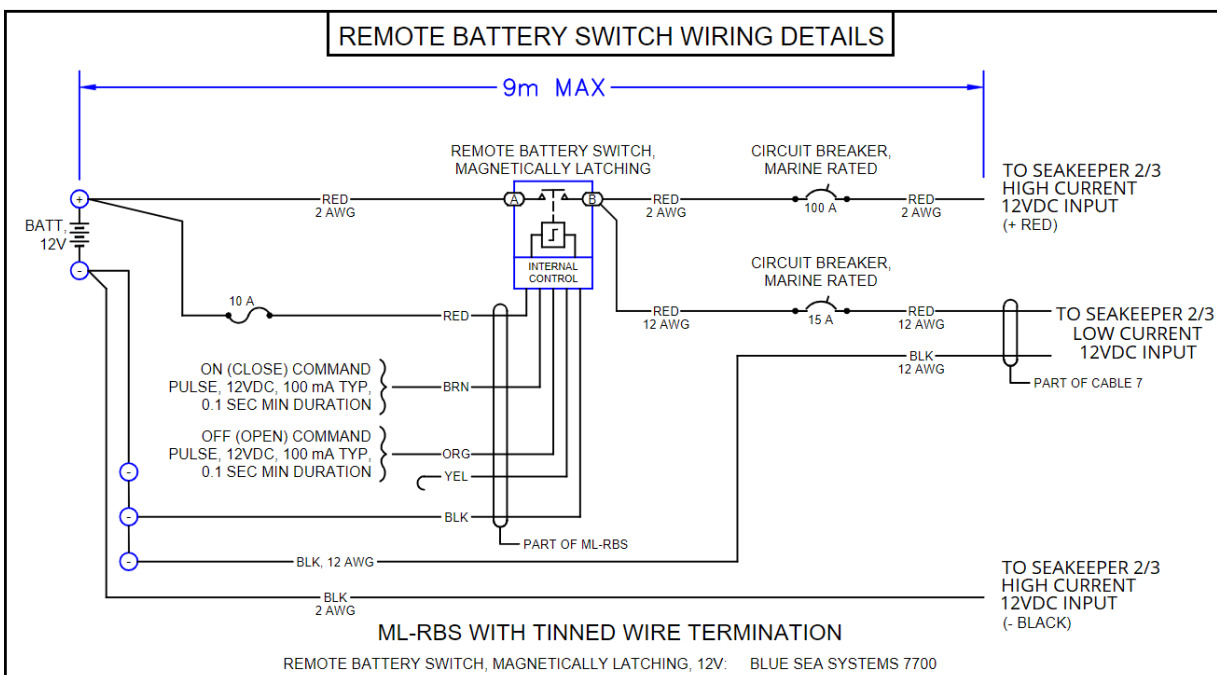

- ii. **INSPECT** DC breakers for ON, tight terminal connections, no wire damage, and no excessive corrosion.
- iii. **COMPARE** voltage readings from battery terminals to output of breakers.
- iv. **IF** any issues found with breakers and wiring in Step 1.b.ii and 1.b.iii, **THEN:**
 - a. **TURN OFF** affected breaker.
 - b. **PERFORM** repairs of affected breaker.
- v. **TURN ON** circuit breaker after repairs completed.

PRODUCT SEAKEEPER SERIES MODELS

Code 111/112/167/168

Step 1 continued

- c. **CHECK** battery as follows:

NOTE:

Seakeeper recommends three (3) 90 Amp-Hour AGM house batteries OR equivalent for Seakeeper 3 models.

- i. **ENSURE** 12VDC source powering Seakeeper has ampacity to carry all non-associated loads **AND** continuous amps for Seakeeper.
 - ii. **IF** battery bank below 12.0V,
THEN CHARGE battery above 12.0V.
 - iii. **IF** a generator powers Seakeeper without batteries,
THEN ENSURE generator output can provide needed power for Seakeeper and other loads.
 - iv. **VERIFY** electrical installation (per [ATTACHMENT 1](#)) ensuring no damage to supply cables.
2. **ACCESS** Seakeeper battery input terminals as follows:

**WARNING!**

PERSONNEL SHOCK HAZARD EXISTS when working on live circuitry.
Seakeeper may start remotely.

- a. **ENSURE** flywheel at zero RPM at display or MFD app.
- b. **TURN OFF** all power to Seakeeper.

PRODUCT SEAKEEPER SERIES MODELS

Code 111/112/167/168

Step 2 continued

- c. **IF** Seakeeper 2,
THEN:
- i. **REMOVE** five hex-head screws of rear panel, shown below.

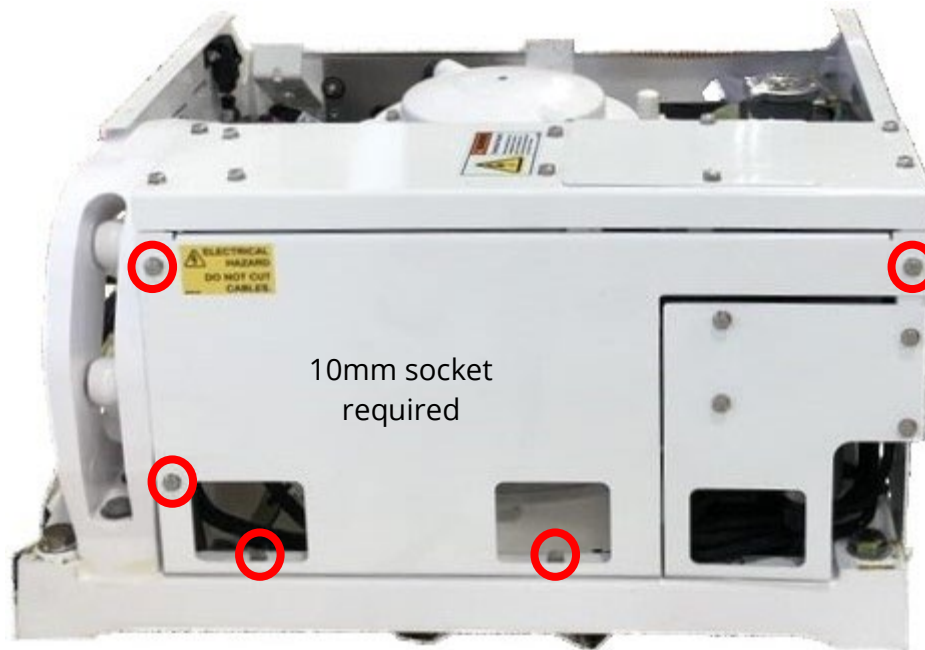

- ii. **TILT** top of rear panel out.
- iii. **REMOVE** battery terminal cover of MDB.

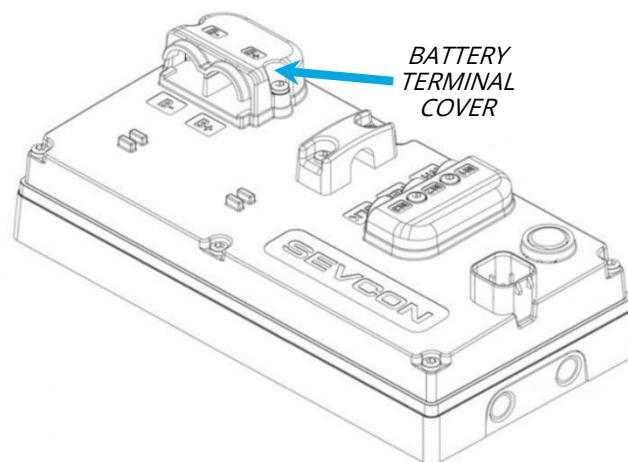

PRODUCT SEAKEEPER SERIES MODELS

Code 111/112/167/168

Step 2 continued

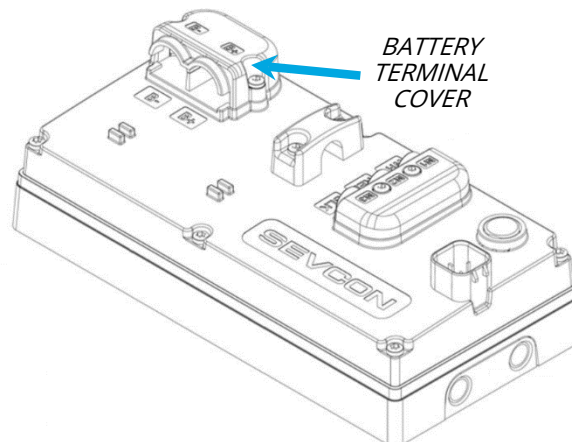
d. **IF** Seakeeper 3,**THEN:**i. **REMOVE** two hex-head screws at top of rear panel, as shown.ii. **LOOSEN** two lower rear panel hex-head screws, as shown.iii. **PULL OUT** top of panel **AND LIFT** rear panel.iv. **REMOVE** battery terminal cover of MDB.

PRODUCT SEAKEEPER SERIES MODELS

Code 111/112/167/168

3. **VERIFY** battery terminal cables are installed in correct location and torqued per [Torque Specification](#) section.
4. **TURN ON** low current DC breaker to Seakeeper.
5. With multimeter in DC volts mode, **MEASURE** input voltage between 10 and 15VDC.
 - a. **RECORD** voltage on service report form.
6. **IF** battery terminals of Seakeeper show significantly lower voltage from battery, **THEN TROUBLESHOOT** vessel electrical line to Seakeeper.

NOTE:

A multimeter, such as a Fluke 269, can capture peak maximum and minimum voltages and is recommended.

7. **PERFORM** operational test of Seakeeper (at dock or underway) with normal underway electrical source aligned:
 - a. **TURN OFF** all breakers to Seakeeper.
 - b. **ATTACH** probes of multimeter in DC VOLTS mode to **B+ AND B-** terminals of MDB.
 - c. **STATION** individual at power supply to Seakeeper, if necessary.
 - d. **TURN ON** all breakers to Seakeeper.
 - e. **MONITOR** multimeter for dipping in voltage below **10.0VDC**.
 - f. **REPEAT** this cycling of power and monitoring voltage **for minimum of three times** to ensure repeatability.
 - g. **IF** voltage did NOT dip, **THEN CONTINUE** in procedure.
 - h. **IF** voltage dipped, **THEN NOTE** any alarm received that will NOT allow reset.
 - i. **TROUBLESHOOT** alarm per applicable code troubleshooting guide.

8. With probes still attached from previous step, **TURN ON** all breakers to Seakeeper.

NOTE:

Possible large vessel loads may be any of following depending on vessel's electrical distribution system and equipment loading. Loads vary on each vessel:

Windlass	Bow thrusters
DC Refrigeration compressor	Inverters
Blowers	Refrigeration clutches
Trolling motors	Engine starter motor (in some cases)

9. **START** Seakeeper flywheel motor spool-up.
10. **WHILE MONITORING** Seakeeper input voltage, **CYCLE** large vessel loads, one by one.
- IF** voltage seen to drop below **10.0VDC** upon start of load, **THEN INSPECT** that load's positive and negative DC cabling for loose bus connections, cable damage, or distribution cable tap locations.
 - IF** spool-up is aborted during test, **THEN RESTART** Seakeeper spool-up.
 - IF** voltage seen to spike above **15.0VDC** upon securing of load, **THEN PERFORM** vessel electrical system evaluation.
 - RECORD** results from tests.
11. **ALLOW** Seakeeper to reach target RPM.
12. **UNLOCK** Seakeeper.

PRODUCT SEAKEEPER SERIES MODELS

Code 111/112/167/168

13. **WHILE MONITORING** Seakeeper input voltage,
CYCLE large vessel loads, one by one.
 - a. **IF** voltage seen to drop below **9.0VDC** upon start of load,
THEN INSPECT that load's positive and negative DC cabling for loose bus connections, cable damage, or distribution cable tap locations.
 - b. **IF** voltage seen to spike above **15.0VDC** upon securing of load,
THEN PERFORM vessel electrical system evaluation.
 - c. **RECORD** results from tests.

14. **IF** alarm persists,
THEN CONTACT Seakeeper Product Support Team at support@seakeeper.com with all test results data and electrical alignment at time of alarm (i.e., on shore power or underway).

******* END *******

ATTACHMENT 1: DC CABLE BLOCK DIAGRAMS

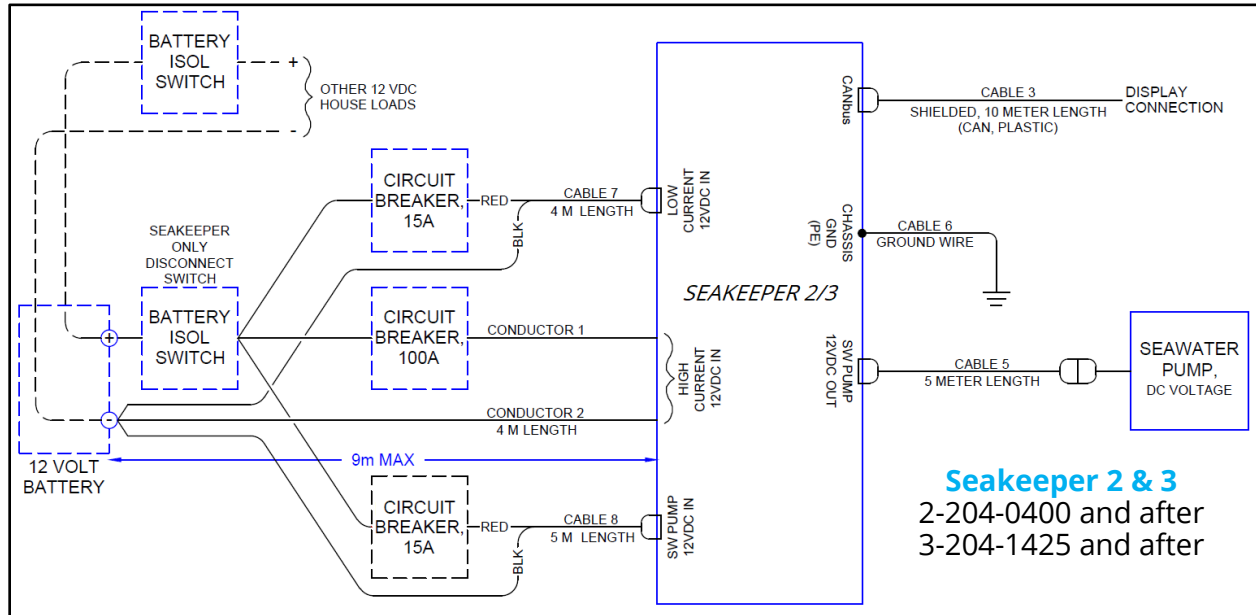

SEAKEEPER 2 & 3 WIRING BLOCK DIAGRAM

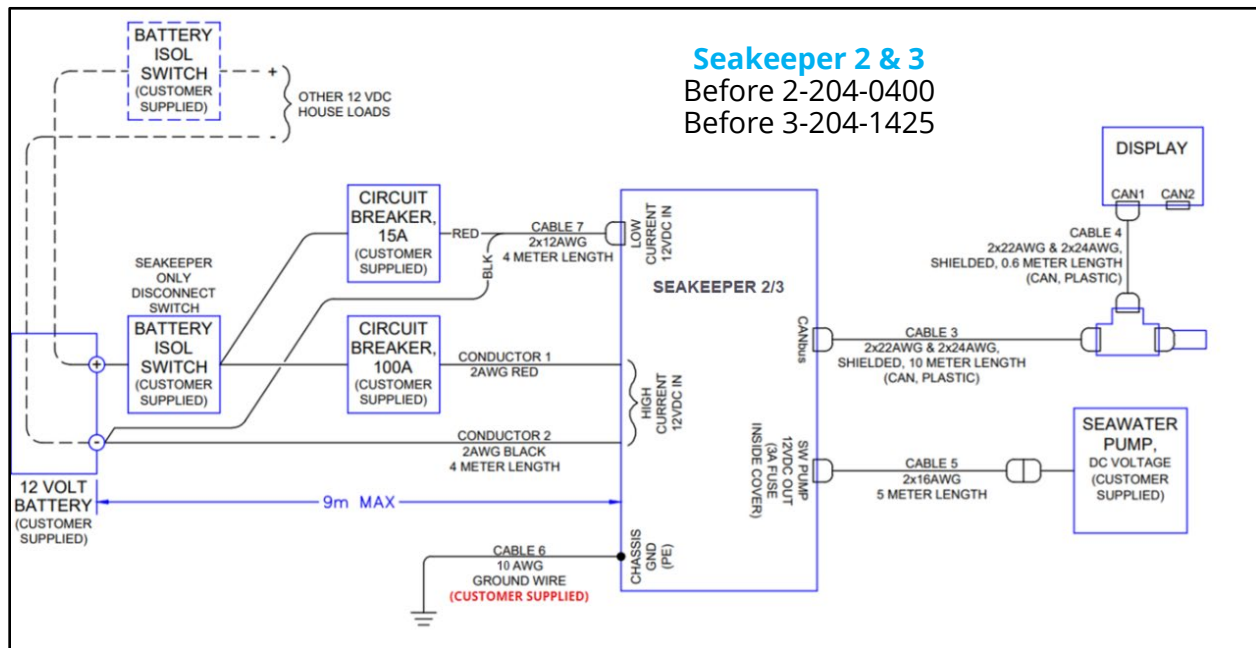



ATTACHMENT 2: VOLTAGE THRESHOLDS

VOLTAGE CODE THRESHOLDS				
ALARM / WARNING CODE	SOURCE	MODELS		
		2	3	3DC
40 – DC INPUT VOLTAGE HIGH	GCM	>15	>15	>15
41 – DC INPUT VOLTAGE LOW	GCM	<10	<10	<10
111 – DC INPUT VOLTAGE LOW (unlocked)	GCM ¹	<11.1 & <6030 RPM	<11.3 & <5661 RPM	<11.1 & <4224 RPM
112 – DC INPUT VOLTAGE LOW (spool-up)	GCM ²	<11.1 & <7650 RPM	<11.3 & <7182 RPM	<11.1 & <5440 RPM
167 – HIGH CURRENT DC VOLTAGE LOW	DRIVE At hi-current input terminals	<10	<10	NA
168 – HIGH CURRENT DC VOLTAGE HIGH	DRIVE At hi-current input terminals	>16	>16	NA
NOTES				
1 Excessive precession speed loss (loss of .65% of target speed when unlocked) and Battery Manager (battery voltage low) functions minimize power consumption to <600W				
2 Slow Spool Up (speed change during spool up of flywheel is < 10rpm in 1 min for 2 consecutive minutes) and Battery Manager (battery voltage low) functions limit power to <600W				

PRODUCT SEAKEEPER SERIES MODELS

CODE 123

To troubleshoot and reset the "BATTERY STATE OF CHARGE LOW" warning (Code 123).

BACKGROUND

This warning is only expected on DC-powered Seakeepers installed on boats equipped with a lithium battery bank supplying the Seakeeper. The warning code is triggered when the NMEA2000 network State of Charge signal (SOC) reaches the setting on the cut-off threshold slider of the Battery Monitoring Configuration screen. The factory setting for this threshold is 20% but may be selected by the user from 10 to 30% state of charge.

When the battery charge threshold is reached, the indication will be displayed on the MFD app/5" Display Home screen by showing the battery icon in red and empty. The Seakeeper will reduce its power draw from the battery by lowering the flywheel RPM. The ramp-down of Seakeeper power continues until 67% of the flywheel target speed is reached. Any further reduction in battery charge will result in the Seakeeper locking the enclosure and coasting the flywheel.

To reset the warning, one must recharge the lithium battery bank supplying the Seakeeper. The battery monitor may be faulty if the actual battery voltage is above 11.5VDC.

REFERENCES

[TB-90621 – Battery Sizing Recommendations](#)

PRECAUTIONS

See [PRECAUTIONS](#) section of Introduction.

PROCEDURE

1. With power aligned to Seakeeper, **CHECK** Seakeeper DC voltage reading on Service screen of MFD app / 5" display.

2. **IF** voltage is below 11.4VDC, **THEN CHARGE** lithium battery supplying Seakeeper.

3. **IF** voltage 11.4VDC or higher, **THEN PERFORM** following:

- a. **CHECK** boat's battery monitoring display for valid State of Charge (SOC) signal.
- b. **IF** no valid SOC signal from battery monitor equipment, **THEN TROUBLESHOOT** battery monitor equipment.
- c. **IF** valid SOC signal exists from battery monitor equipment, **THEN TROUBLESHOOT** NMEA2000 backbone and drop cable to Seakeeper.

4. To view Seakeeper Battery Monitoring Configuration, **PRESS AND HOLD** battery icon on Home screen until pop-up window for Battery Monitoring Configuration appears.

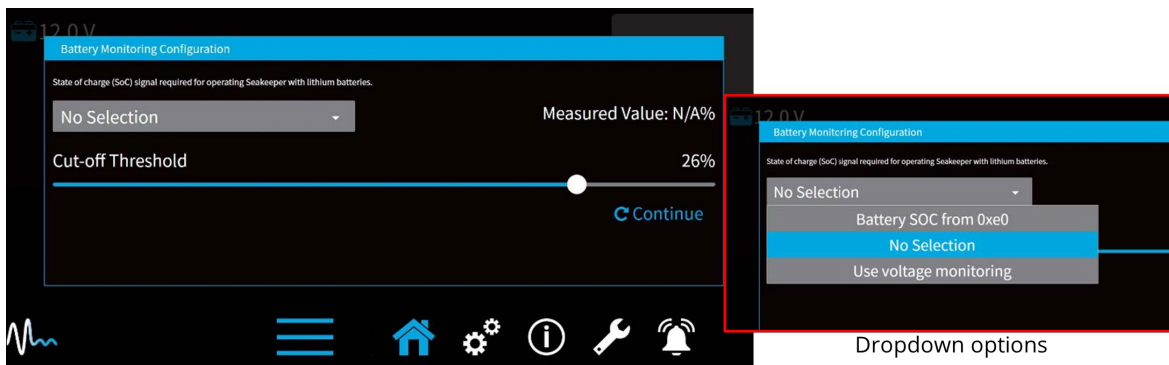
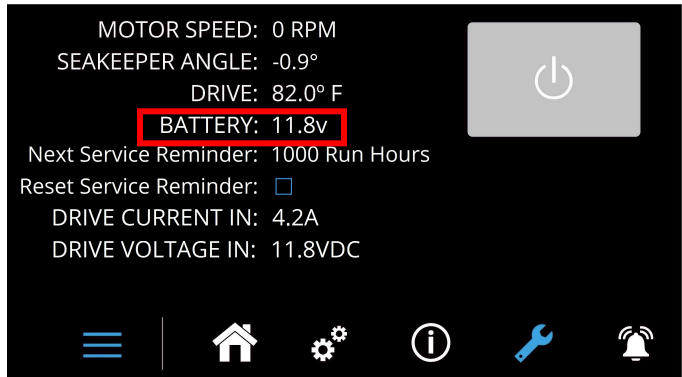

Dropdown options

******* END *******

PRODUCT SEAKEEPER SERIES MODELS

CODE 129/130 🏠

To troubleshoot and repair the cause of the “INCORRECT SERIAL NUMBER” alarm (Code 129) and the “MODEL CHANGE DETECTED” alarm (Code 130).

BACKGROUND

These codes are not expected in installed Seakeeper models under normal circumstances. The alarms may arise during or immediately after programming with the Seakeeper Service Tool application or programming computer software. If an erroneous model number or serial number is entered, the GCM should recognize the error and trigger this alarm to notify the technician.

REFERENCES

[SWI-118 - Seakeeper Service Tool User Guide](#)

PRECAUTIONS

See [PRECAUTIONS](#) in Introduction section.

PROCEDURE

1. **IF** alarm received during or after GCM programming,
THEN:
 - a. **VERIFY** correct serial or model number from associated Seakeeper enclosure label.
 - b. **RE-PROGRAM** GCM with correct data.

2. **IF** alarm received after installing GCM,
THEN:
 - a. **REPLACE** GCM **OR PROGRAM** GCM using Seakeeper Service Tool application.
 - b. **RETURN** replaced GCM to Seakeeper.

******* END *******

CODE 131

Troubleshoot and repair the "GPS SIGNAL LOST" notice: Code 131.

BACKGROUND

This notice is received when there is an absence or loss of GPS speed (speed over ground/SoG) signal from the NMEA backbone connection of the ConnectBox. Per the installation manual, a GPS device is required for the SoG signal. This notice applies to any Seakeeper model equipped with the ConnectBox.

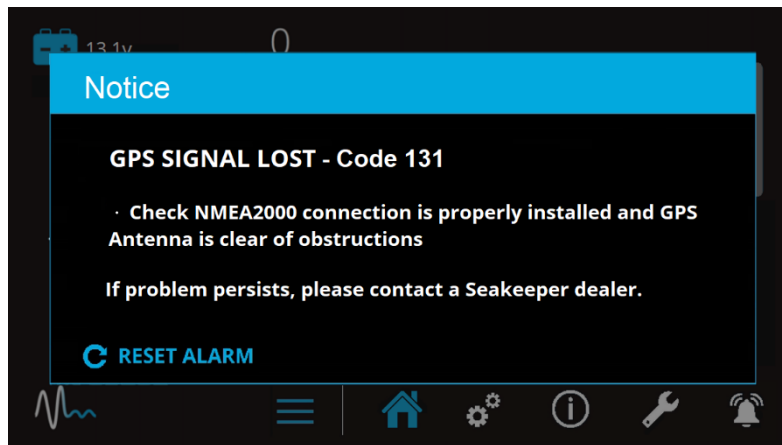

When the SoG signal is available, the input power will remain the same; the Seakeeper will spool and regulate the sphere's precession, limiting it to a more upright position at higher boat speeds. When the boat speed is reduced, the sphere begins to precess normally again. When the SoG signal is lost, the Seakeeper will allow spooling and SEA Mode, but no precession/stabilization will be available.

REFERENCES

[TB-90640 – ConnectBox Connection Requirements](#)

[TB-90555 – Seakeeper Display Software Compatibility](#)

PRECAUTIONS

See [PRECAUTIONS](#) in Introduction section.

PROCEDURE**CAUTION:**

CONNECTBOX DAMAGE MAY OCCUR if NMEA cable
tightened with excessive force.

**WARNING:**

PERSONNEL SHOCK HAZARD EXISTS when working on live circuitry.
Seakeeper may start remotely.

1. **ENSURE** flywheel at zero RPM at display or MFD app.
2. **CYCLE** DC control power to Seakeeper.
3. **IF** GCM software 11.130 or later,
THEN CHECK NMEA2K Status:
 - a. **NAVIGATE** to Seakeeper app Settings page (gears icon).
 - b. **HOLD** gears icon button until hidden Settings page appears.
 - c. **SELECT** 'System' tab.
 - d. **VERIFY** 'NMEA2K Status' indicates *OK*.
 - e. **CHECK** GPS tab to ensure at least one GPS device listed.
 - f. **IF** 'NMEA2K Status' indicates *Error* or flickering between *OK* and *Error*,
THEN PERFORM checks for NMEA CAN faults in this procedure.
 - g. **IF** NMEA2000 Status in error and GPS device list blank,
THEN CHECK boat-side NMEA2000 wiring.
 - h. **IF** NMEA2000 Status *OK* and GPS device list populated with at least one device,
THEN REPLACE ConnectBox.
 - i. **IF** issue persists,
THEN LOG data on Seakeeper Service Tool app **AND SUBMIT** data to Seakeeper Product Support Team.

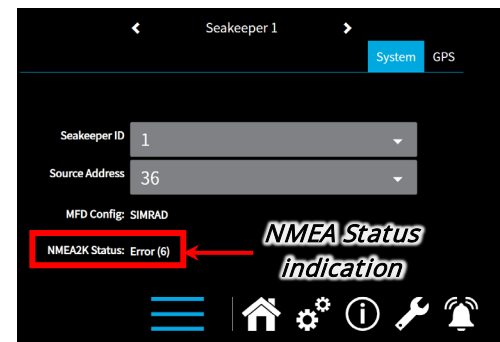

4. With earlier GCM software, **VERIFY** Seakeeper appears on MFD's list of NMEA-connected devices.
 - a. **IF** Seakeeper does not appear in list, **THEN PERFORM** checks of steps 6 through 9 for NMEA CAN faults.
5. **ENSURE** vessel GPS receiver is operating by viewing output at appropriate display onboard.
6. **VERIFY** integrity of NMEA drop cable from NMEA Backbone to ConnectBox.

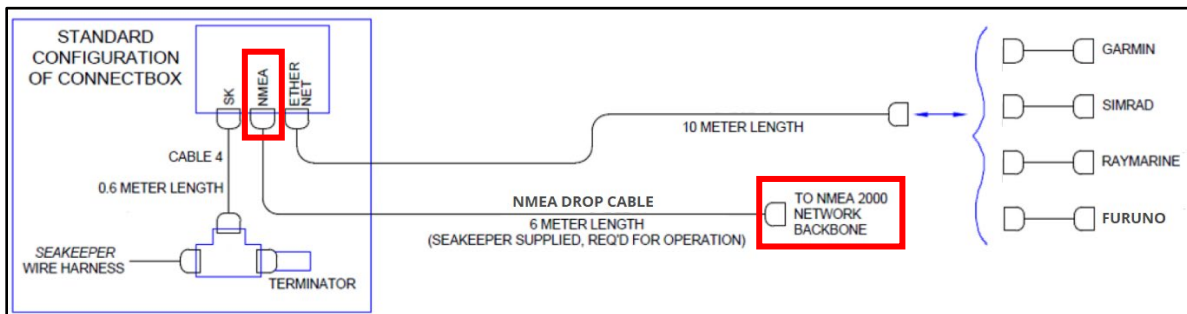

- a. **INSPECT** for sharp bends in cable routing.
 - b. **INSPECT** for fraying or abraded insulation.
 - c. **ENSURE** cable no longer than 20 ft (6 m).
7. **INSPECT** connectors of NMEA drop cable at ConnectBox and NMEA Backbone for corrosion or moisture intrusion.
 8. **CHECK** GPS antenna and NMEA2K backbone for following:
 - a. **ENSURE** GPS antenna has clear view of sky.
 - b. **ENSURE** GPS antenna is outside any Radar Beam, either above or below.
 - c. **ENSURE** GPS antenna is below SATCOM Antenna Beam if installed.
 - d. **ENSURE** total length of drop cable from backbone to GPS is NOT longer than 20 ft. (6 m).
 - e. **ENSURE** NMEA2000 backbone voltage at minimum of 11VDC.

PRODUCT SEAKEEPER SERIES MODELS

Code 131

9. **PERFORM** following electrical checks of NMEA drop cable to ConnectBox:

- a. **TURN OFF** all power to Seakeeper.
- b. **DISCONNECT** NMEA drop cable from ConnectBox **AND** vessel NMEA Backbone.
- c. With multimeter in resistance mode, **VERIFY** no electrical short exists between any two pins.
- d. **CHECK** continuity of each lead in drop cable.
- e. **IF** Step 9.c or 9.d **UNSATISFACTORY**, **THEN REPLACE** NMEA drop cable.
- f. With cable connected to NMEA backbone, **CHECK** voltage, at ConnectBox end of cable, between 10 – 15VDC (between pins **2** and **3**).
- g. **IF** voltage is below 10VDC, **THEN REEVALUATE** estimated voltage drop on NMEA backbone given number of devices and placement of power supply.

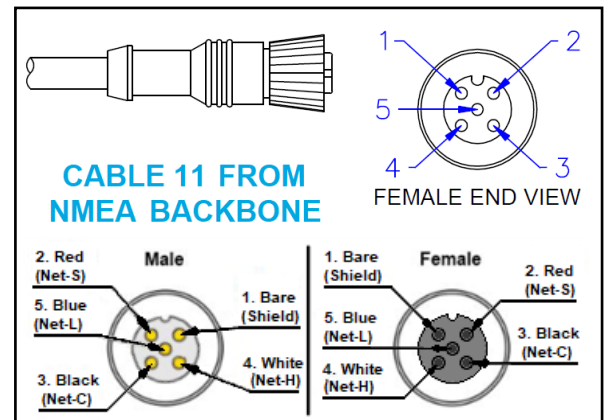
10. **PERFORM** following:

- a. **DISCONNECT** all cables from ConnectBox.
- b. **REMOVE** ConnectBox from bracket.

NOTE:

If cables overtightened, connectors could rotate and break off from underlying circuit board. Connector may feel loose, or their locating key would be obviously rotated into new orientation (versus 12 o'clock position).

- c. **EXAMINE** connector ports and pins on ConnectBox for damage.
- d. **RESTORE** all connections.

11. **TURN ON** all power breakers to Seakeeper.

PRODUCT SEAKEEPER SERIES MODELS

Code 131

12. **IF** GCM software version 11.110 or after and multiple GPS transmitters available,
THEN:

- a. **NAVIGATE** to Settings screen (gears icon).
- b. **PRESS AND HOLD** gears icon until Settings hidden screen appears.
- c. **SELECT** GPS tab at top of screen.
- d. From GPS signal transmitter list, **SELECT** appropriate GPS transmitter with signal that allows clearing of alarm

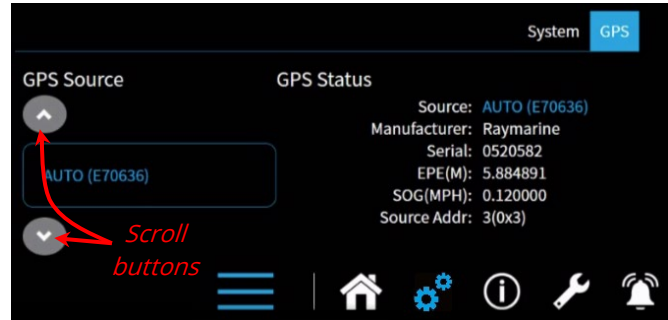

13. **IF** earlier software versions, **AND** multiple GPS signals are available on the NMEA2K CAN, **AND** no stabilization performance is noted due to loss of SoG signal,
THEN:
- a. **PERFORM** sea trial at less than 10 knots.
 - b. **DISCONNECT** GPS sources one at a time to evaluate Seakeeper performance.
 - c. **IF** stabilization improves upon removal of a transmitter,
THEN UPDATE GCM and ConnectBox software.
14. **IF** alarm persists,
THEN CONTACT Seakeeper Product Support Team at support@seakeeper.com with results of all tests and inspections.

******* END *******

PRODUCT SEAKEEPER SERIES MODELS

CODE 150-153/165

To troubleshoot and repair codes:

“LOWER BEARING SENSOR FAULT – HIGH” warning (Code 150)

“LOWER BEARING SENSOR FAULT – LOW” warning (Code 151)

“UPPER BEARING SENSOR FAULT – HIGH” warning (Code 152)

“UPPER BEARING SENSOR FAULT – LOW” warning (Code 153)

“BEARING TEMP SENSORS NOT FUNCTIONING” alarm (Code 165)

BACKGROUND

Seakeeper bearing temperature monitoring is accomplished with negative temperature coefficient (NTC) thermistors. These special resistors have a predictable change in resistance with the temperature change. A bad connection is the most likely cause of intermittent or failed temperature readings. When a thermistor wiring failure occurs, it produces one of the above codes. The alarm Code 165 will lock a running Seakeeper and spool motor down. Warning codes will not stop a Seakeeper from stabilizing; they will continue to stabilize after receiving a warning. These codes are associated with the bearing thermistors found in Seakeeper 5/3DC (EM) and 9/7HD through 35/30HD models.

Alarm code 165 indicates a failure in the common wiring of both bearing thermistors, indicating out-of-range high or low temperature simultaneously.

Code 150 or 152 warns of a failure of the thermistor that results in a 0-volt signal (out-of-range high temperature) at the GCM input circuitry. The most likely cause of this failure is a +5VDC lead open or a component failure within the GCM.

Conversely, code 151 or 153 warns of a failure that results in a +5-volt signal (out-of-range low temperature) at the GCM input circuitry. The most likely cause is a short +5VDC supply to the ground wire in the thermistor circuit or a component failure within the GCM.

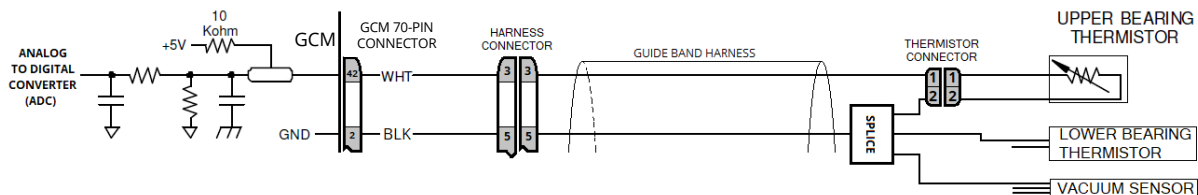

EXAMPLE SEAKEEPER 9 UPPER THERMISTOR CIRCUIT

PRECAUTIONS

See [PRECAUTIONS](#) in Introduction section.

PROCEDURE**WARNING!**

PERSONNEL SHOCK HAZARD EXISTS when working on live circuitry.
Seakeeper may start remotely.

1. **ENSURE** flywheel at zero RPM at display or MFD app.
2. **TURN OFF** all power to Seakeeper.
3. At bearing temperature thermistor on enclosure, **CONFIRM** electrical connections are secure.
 - a. **IF** connection(s) loose,
THEN:
 - i. **RECONNECT** any loose connection.
 - ii. **TURN ON** low current DC power to Seakeeper.

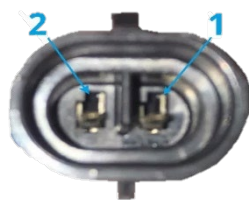

*Thermistor connection to
harness*

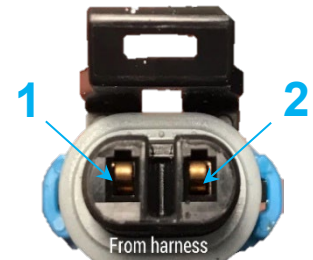

*Harness connector to
thermistor*

- iii. **CHECK** all display codes clear.
- iv. **TURN OFF** low current DC power to Seakeeper.

PRODUCT SEAKEEPER SERIES MODELS

Code 150 – 153/165

4. **UNPLUG** effected thermistor from wire harness.
5. **INSPECT** for loose wire connections within connectors.
6. With multimeter in Resistance mode, **VERIFY** resistance between two pins (of sensor) is between 1000Ω and 50,000Ω.

Thermistor connection to harness

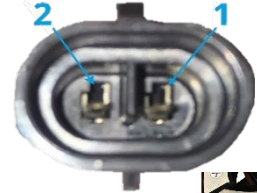

Resistance vs. Temperature			
Temperature °C / °F	Resistance (Ω)	Resistance Tolerance	Tolerance ±°C / °F
25 / 77	10,000	5.00	1.14 / 2
85 / 185	1070	6.77	2.15 / 4



Meter in this photo is displaying 11.05 KΩ.

- a. **IF** resistance is higher than 50,000Ω **OR** less than 1000Ω, **THEN REPLACE** bearing thermistor.
 - b. **CYCLE** DC control power to Seakeeper **AND CHECK** all display codes clear.
7. **REMOVE AND SWAP** effected thermistor with opposite thermistor's harness connection.

NOTE: It will be necessary to cut cable tie(s) holding thermistor wiring to perform this step. Ensure cable ties are replaced after work completed.

- a. Momentarily **CYCLE** DC power to Seakeeper.

NOTE:

Thermistors are assembled with a small amount of Timtronics® White Ice 510 thermal conductive paste applied to their sensor tips.



- b. **IF** unaffected sensor is now in alarm (e.g., Code 150 was originally in alarm. After re-energizing control power, Code 152 is in alarm), **THEN REPLACE** first thermistor.
- c. **RESTORE** routing of guide band connectors to as-found condition.
- d. **IF** same alarm flashed **AFTER SWAPPING LEADS ON THERMISTORS**, **THEN CONTINUE** with this procedure.

PRODUCT SEAKEEPER SERIES MODELS

8. With multimeter in DC Volts mode and DC power aligned, **CONFIRM** 5VDC across two pins of guide band harness connector of effected thermistor.
 - a. **IF** NO voltage sensed across two pins, **THEN LOCATE AND DISCONNECT** guide band connection near rear of foundation.
 - b. On guide band's harness, **MEASURE** for low resistance (continuity) between affected sensor's harness connector pin **1** and guide band connector Pin **3** (for Upper Thermistor) or pin **6** (for Lower Thermistor).



Photo showing location of Guide Band connector inside foundation near guide band bracket and below manifold.



Figure 1: Seakeeper 9 bearing thermistor wire diagram (Other models similar)

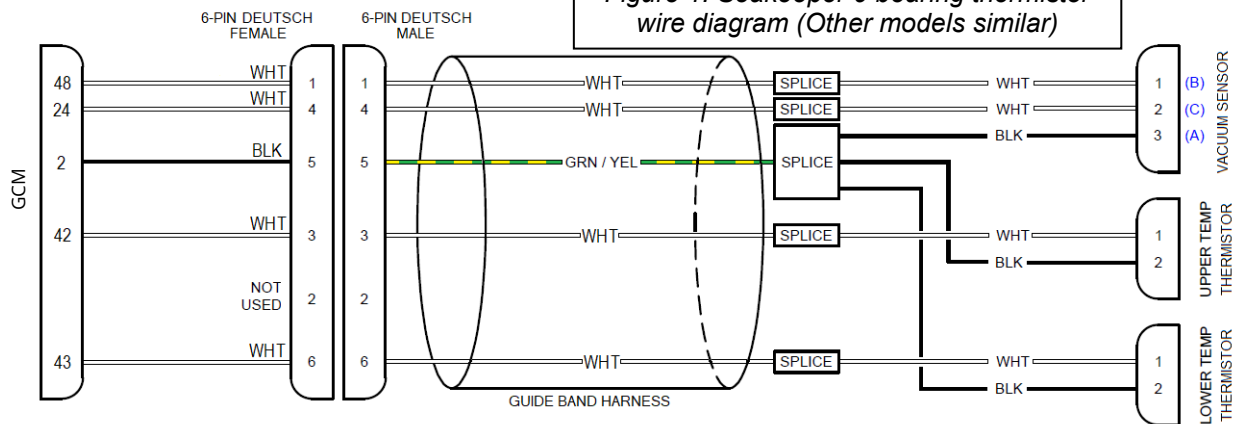

PRODUCT SEAKEEPER SERIES MODELS

Code 150 – 153/165

Step 8 continued

- c. On guide band's harness, **MEASURE** for resistance below 0.3Ω between effected sensor's harness connector pin **2** and guide band connector pin **5**.

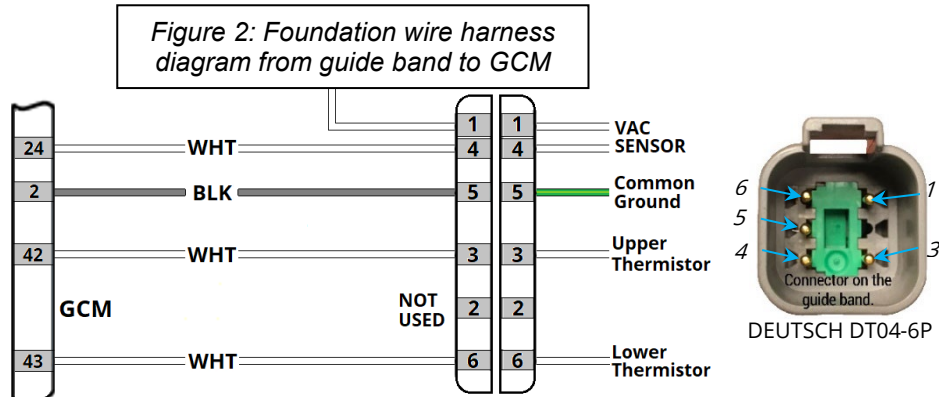

- d. **IF** either measurement in Step 8.b or 8.c results in an open (high resistance/no continuity), **THEN REPLACE** guide band wire harness.
- i. **CYCLE** DC Control Power to Seakeeper.
 - ii. **VERIFY** all display codes clear.

Step 8 continued

- e. **IF** low resistance found in both 8.b and 8.c,
THEN PERFORM following (see Figure 2, previous page):

- i. **ENSURE** DC Control Power disconnected.
- ii. **DISCONNECT** GCM 70-pin connector.
- iii. **REMOVE** white face plate from 70-pin connector.
- iv. **INSPECT** connector for loose sockets/wire connections.

- v. **MEASURE** for below 0.3Ω between foundation wire harness connector at guide band and GCM 70-pin connector as follows:

1. **IF** Lower Thermistor is effected sensor,
THEN MEASURE for below 0.3Ω between female pin **6** of foundation wire harness guide band connector and GCM pin **43**.
2. **IF** Upper Thermistor is effected sensor,
THEN MEASURE for below 0.3Ω between female pin **3** of foundation wire harness guide band connector and GCM pin **42**.
3. **MEASURE** between female pin **5** of foundation wire harness guide band connector and GCM pin **2**.

- vi. **IF** any measurement of Step 8.e.v showed resistance above 0.3Ω ,
THEN REPLACE foundation wire harness.

1. Once replaced, **CYCLE** DC control power to Seakeeper.
2. **VERIFY** all display codes clear.

9. **IF** previous steps failed to clear code,
THEN ENSURE all power removed from Seakeeper.

10. **REPLACE** GCM.

11. **TURN ON** all power to Seakeeper.

12. **VERIFY** all display codes clear.

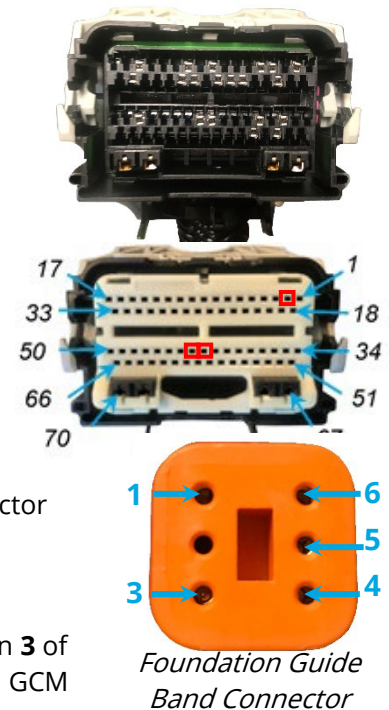

SEAKEEPER TROUBLESHOOTING GUIDE - 106



PRODUCT SEAKEEPER SERIES MODELS

Code 150 – 153/165

13. **IF** all codes clear,
THEN PERFORM sea trial to ensure all issues addressed, if possible.

14. **IF** codes will NOT clear,
THEN CONTACT Seakeeper Product Support Team at support@seakeeper.com with results of all tests and summary of steps taken to troubleshoot.

******* END *******

PRODUCT SEAKEEPER SERIES MODELS

CODE 163

To troubleshoot and repair the "Slow Spool Up" alarm (Code 163).

BACKGROUND

"Slow Spool Up" is reported by the GCM when it senses a speed rise of less than 10 RPM in 1 minute for two consecutive minutes during spool up after the operator presses start. Code 72 (Motor Underspeed) is similar but is triggered when the Seakeeper is in SEA MODE.

Code 163 reports an adverse condition preventing the spool-up of the flywheel. If any other recent drive-related alarms are in history, they should be addressed first.

If this alarm is accompanied by Code 98 (AC Mains Low alarm) in AC-powered models or by Code 166 (DC Mains Low alarm) in DC-powered models, the input power supply to the MDB is likely the cause and should be pursued first.

Another alarm of which to be aware is Code 128 (Vacuum Leak warning) accompanying this alarm. If a vacuum leaks, air resistance to the flywheel spinning may overcome the motor's ability to raise the speed to operational levels.

Motor lead testing is referenced in this guide to determine the condition of the insulation and potting of the motor drive cable and flywheel motor. See [SWI-124 for Seakeeper Motor Lead Testing](#).

TABLE 1: SEAKEEPER MODEL VOLTAGES				
MODEL	DC MAINS	AC MAINS	DC CONTROL	MOTOR VOLTAGE
Seakeeper 2 & 3	12	-	12	48VDC
Seakeeper 3DC	12	-	12	48VDC
Seakeeper 5 (EM)/5 & 6	-	110 / 230	12	400VDC
Seakeeper 9 & above	-	230	24	400VDC

REFERENCES

[SWI-124 - Seakeeper Motor Lead Testing](#)

[SWI-129 - Seakeeper Vacuum Gauge Operation](#)

PRECAUTIONS

See [PRECAUTIONS](#) in Introduction section.

PROCEDURE**SECTION 1, INITIAL FINDINGS**

1. **IF** recent drive-related alarm(s) present in alarm history,
THEN ADDRESS those alarms first (identified by 'DRIVE' in description).
2. Due to potential for sphere replacement, **RECORD** all interview answers and testing results.
3. **INTERVIEW** owner/operator by asking:
 - a. When did issue first appear (conditions in which alarm occurred)?

 - b. Has the Seakeeper achieved full speed since? _____ YES/NO
 - c. If no, what was maximum speed noted? _____ RPM
 - d. Did alarm occur at the dock or underway? _____
 - i. If at dock AND DC-powered model, was battery charged overnight? _____ YES/NO
 - ii. If DC-powered, what is battery voltage at time of alarm? _____ VDC
 - iii. If underway, how long after leaving dock did alarm occur? _____
4. **IF** speed 200+ RPM in Step 3.c or unknown and Code 128 or 137 found in alarm history,
THEN PROCEED to [Code 128 or 137 troubleshooting](#).
5. **VISUALLY INSPECT** motor power cable from MDB to feed-through in enclosure. (Cracked/damaged insulation, kinked cable)
 - a. **DOCUMENT** issues with photo(s).
6. **IF** speed 200+ RPM in Step 3.c and no vacuum sensor,
THEN PROCEED to [SWI-129 - Vacuum Gauge Operation](#) to determine enclosure pressure.
 - a. **IF** enclosure pressure satisfactory (less than 85 Torr),
THEN PROCEED to [Section 2](#) for AC models or [Section 3](#) for DC models.
 - b. **IF** enclosure pressure unsatisfactory (above 85 Torr),
THEN PROCEED to [Code 128 troubleshooting](#).



SECTION 2, AC-POWERED MODELS**WARNING:**

PERSONNEL SHOCK HAZARD EXISTS when working on live circuitry.
Seakeeper may start remotely.

1. **ENSURE** Seakeeper in safe condition:
 - a. **ENSURE** flywheel at zero RPM at display/MFD app.
 - b. **TURN OFF** all power to Seakeeper.
2. **REMOVE** MDB cover.
3. **ENSURE** interior of MDB is free of moisture.
4. **DISCONNECT** AC Seawater Pump leads from their terminal, if equipped.
5. **VERIFY** leads at "MOTOR" terminal are in proper position by color and ground cable attached
 - a. **IF** issues found with motor leads,
THEN CORRECT motor lead issues.

6. **VERIFY** leads are crimped properly, fully inserted into terminal, **AND** locked firmly.

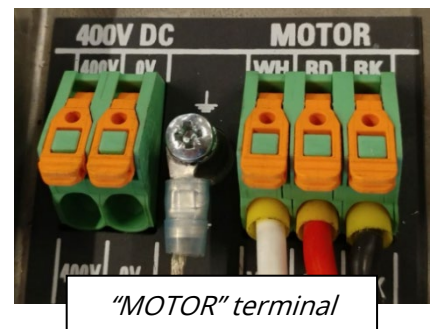
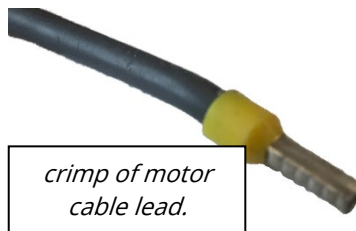

- a. **IF** terminal block orange tab will not lock (as shown to right), **THEN:**
 - i. **ROTATE** crimp.
 - ii. **RELOCK** crimped lead.
7. **IF** any issues found with leads, **THEN CORRECT** issues with motor leads.

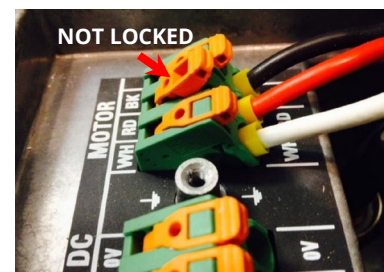

PRODUCT SEAKEEPER SERIES MODELS

Code 163

8. **PERFORM** following at motor drive:
 - a. **LOOSEN** MDB feed-through grommet.



- b. **EXAMINE** motor drive cable insulation at grommet.
 - c. **IF** insulation damage found
THEN CONTACT Seakeeper Product Support Team at support@seakeeper.com.
9. **TURN ON** AC power supply breaker to Seakeeper.
10. With multimeter in AC Volts mode, **MEASURE** voltage at "AC INPUT" terminal between black and white terminals.

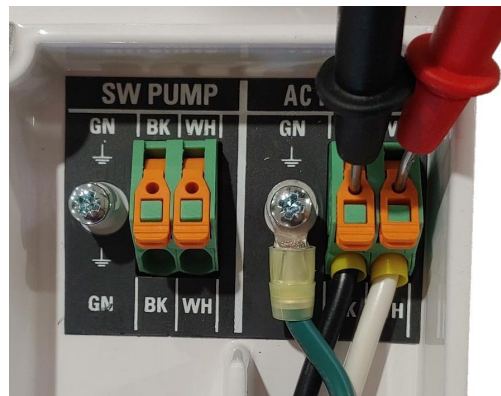

11. **IF** voltage below 188 VAC for 230V model (97 VAC for 110V model) or above 264 VAC for 230V model (132 VAC for 110V model),
THEN TROUBLESHOOT vessel electrical supply.

NOTE:

Spooling of flywheel must be kept to a minimum to perform motor lead testing on a stationary flywheel. A higher flywheel speed will require a longer wait to return to zero RPM.

12. **ENSURE** Seakeeper flywheel at zero RPM.
13. **TEST** voltage at "400V DC" terminal.
 - a. **RECORD** voltage in service report form.
14. **IF** voltage at "400V DC" terminal is NOT between 390 and 400VDC,
THEN REPLACE MDB.
15. **TURN OFF** AC power breaker to Seakeeper.
16. **RECONNECT** AC Seawater Pump leads to their terminal, if applicable.
17. **IF** checks above satisfactory
THEN PERFORM motor lead testing per [SWI-124](#).
18. **IF** any megohm test results are 100 Megohms or less,
THEN CONSIDER reading(s) UNSATISFACTORY **AND CONTINUE** in this procedure.
19. **TORQUE** MDB cover M4 screws to **19 in-lbs (2.2 Nm)**.
20. **PERFORM** following:
 - a. **TAKE** photo of information screen and all alarm history pages.
 - b. **RECORD** 30 second video within one yard (one meter) of Seakeeper upon start of spool up with minimal background noise.
 - c. **CONTACT** Seakeeper Product Support Team at support@seakeeper.com with following:
 - i. Summary of owner/operator interview
 - ii. Troubleshooting test result values
 - iii. Digital images & video recordings collected (may use DropBox, or similar, if excessive file size).

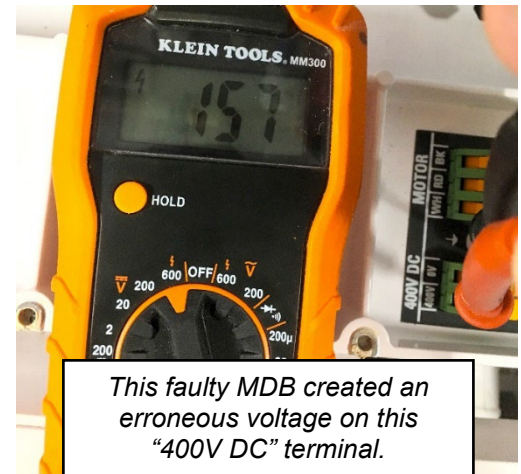

This faulty MDB created an erroneous voltage on this "400V DC" terminal.

SECTION 3, DC-POWERED MODELS



WARNING:

PERSONNEL SHOCK HAZARD EXISTS when working on live circuitry.
Seakeeper may start remotely.

1. **ENSURE** flywheel at zero RPM at display or MFD app.
2. **TURN OFF** all power to Seakeeper.
3. **REMOVE** cover at motor drive contact posts and High DC input terminals. (T20 Torx bit)
4. **INSPECT** for severe corrosion at contacts or damage to cables.
5. **VERIFY** terminal leads torqued per [Torque Specifications](#) section **AND** motor cable leads in correct color location.
6. **TURN ON** high-current DC power breaker to Seakeeper.
7. **MEASURE** high DC voltage at INPUT terminals. [NOTE: Voltage should be 11.2 to 15.0VDC.]



**SEAKEEPER 2 & 3 MDB
(BOTTOM VIEW)**

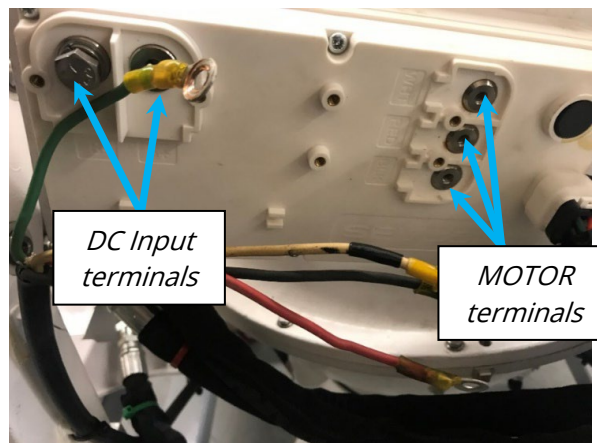

8. **IF** not at proper voltage (11.2 to 15.0V), **THEN TROUBLESHOOT** vessel's electrical system.
9. **TURN OFF** high current DC power to Seakeeper.

NOTE:

Intermittent opens in a wire may not be seen without manipulating the harness to duplicate movement of precession.

10. **PERFORM** motor lead testing per [SWI-124](#).
11. **IF** any temperature-corrected resistance is less than 100 Megohms, **THEN CONSIDER** those readings UNSATISFACTORY.
12. **DOCUMENT** results of all measurements and photograph any physical damage found.

NOTE:

Completing SF-90683 will minimize time and resources should bearing or sphere replacement be required.

13. **PERFORM** following:
 - a. **COMPLETE** as much information on [SF-90683 – Pre-FRB Swap Checklist](#) as possible.
 - b. **TAKE** photo of information screen and all alarm history pages.
 - c. **RECORD** 30 second video within one yard (one meter) of Seakeeper upon start of spool up with minimal background noise.
 - d. **CONTACT** Seakeeper Product Support Team at support@seakeeper.com with following:
 - i. Summary of owner/operator interview
 - ii. Troubleshooting test result values and SF-90683
 - iii. Digital images & video recordings collected (may use DropBox, or similar, if excessive file size).

***** **END** *****

PRODUCT SEAKEEPER SERIES MODELS

MFD INTEGRATION



To troubleshoot non-code compatibility issues between the Seakeeper 5" Touch Display (P/N 30298) or ConnectBox (P/N 20415) to compatible MFD systems.

BACKGROUND

Seakeeper has MFD-specific Technical Bulletins that cover the integration requirements of Seakeeper 5" Touch Display and ConnectBox to compatible MFDs. Compatible MFD manufacturers include Garmin, Raymarine, Navico / Simrad, and Furuno. Available Technical Bulletins are linked in the following section. Seakeeper or MFD software updates, power-up sequence, and sensitive connections through ethernet expansion hubs may negatively impact compatibility between the Seakeeper and MFD. Not all MFDs available from these manufacturers are compatible; one must ensure the specific device supports Seakeeper per the Seakeeper or MFD compatibility documentation.

The [attachment](#) contains operating experience with MFD compatibility issues. Before contacting the Seakeeper Product Support Team, looking over the lessons learned may be helpful to see if an issue experienced is covered.

REFERENCES

[TB-90478 - Garmin and Seakeeper Compatibility](#)

[TB-90479 - Raymarine and Seakeeper Compatibility](#)

[TB-90480 - NAVICO and Seakeeper Compatibility](#)

[TB-90598 - Furuno and Seakeeper Compatibility](#)

[TB-90555 - Seakeeper Display Software Compatibility](#)

[TB-90640 - ConnectBox Connection requirements](#)

[TB-90896 - ConnectBox Installation Guide](#)

Applicable Seakeeper model [Cable Block Diagram](#)

PRECAUTIONS

See [PRECAUTIONS](#) in Introduction section.

PROCEDURE

1. **VERIFY** Seakeeper display software is most up-to-date version per TB-90555:
 - a. On 5" Display, **VERIFY** most recent display software version loaded on Information page.
 - b. For ConnectBox, **VERIFY** most recent display software version loaded. [**NOTE:** if MFD compatibility is not functioning, Seakeeper Service Tool app will be required]

NOTE:

Seakeeper is not responsible for updating MFD manufacturer software.

2. **VERIFY** appropriate and latest MFD manufacturer's software version loaded on MFD per relevant MFD Compatibility Technical Bulletin, listed in references section.
3. **ENSURE** ethernet cable is connected to correct connection at 5" Display or ConnectBox, as shown.

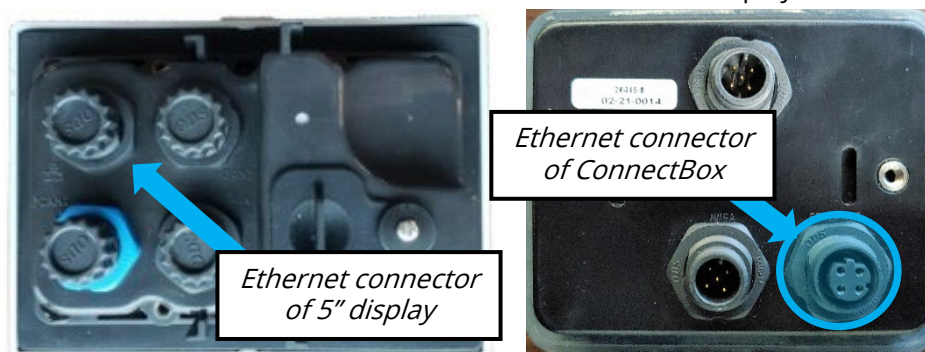

- a. Compatibility cable part numbers are as follows:
 - i. Garmin Ethernet Wire Harness Cable Assembly – P/N 20373
 - ii. Raymarine Ethernet Cable Assembly – P/N 20380
 - iii. NAVICO / Simrad Ethernet Wire Harness Cable Assembly – P/N 20346
 - iv. Furuno Ethernet Wire Harness Cable Assembly – P/N 20506

4. **VERIFY** all display connections made securely from Seakeeper ethernet connection to MFD.

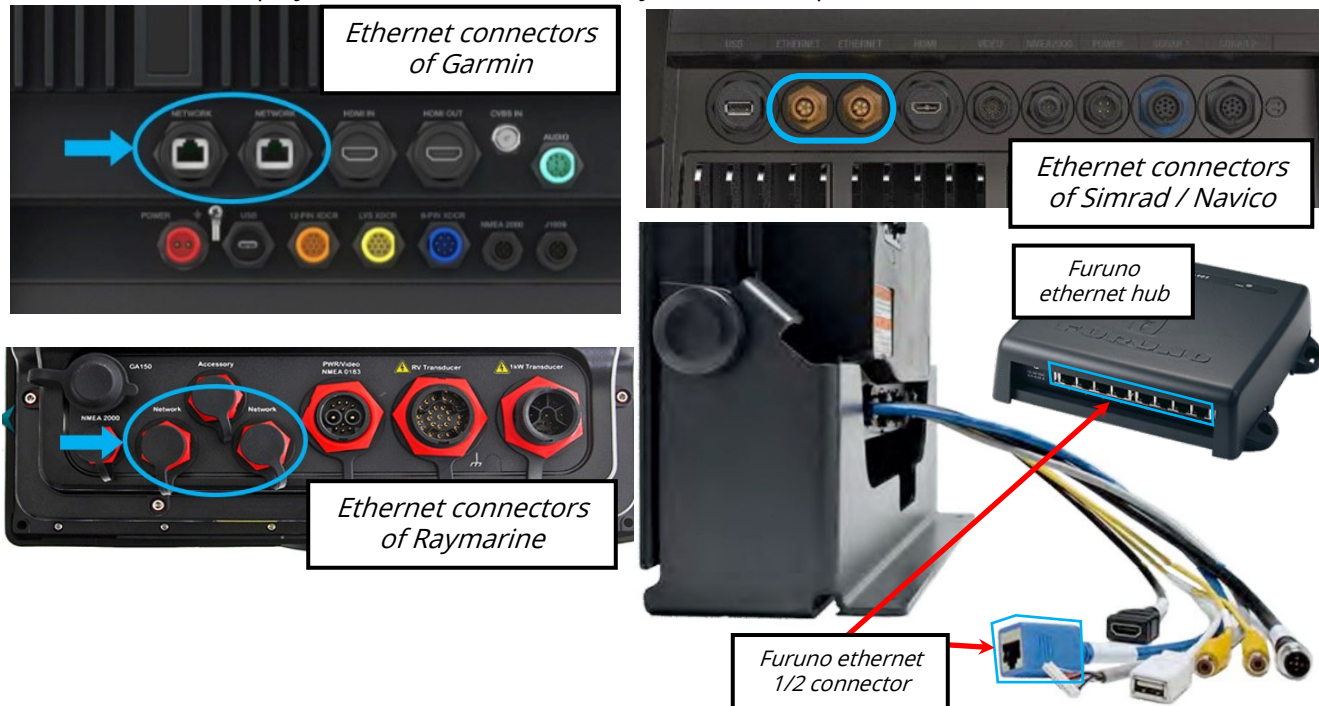

5. Using appropriate MFD Compatibility Technical Bulletin referenced, **ENSURE** ConnectBox or 5" display is correctly synchronized with MFD device.

a. On 5" Display, **SELECT** appropriate MFD option from dropdown list on Settings page.

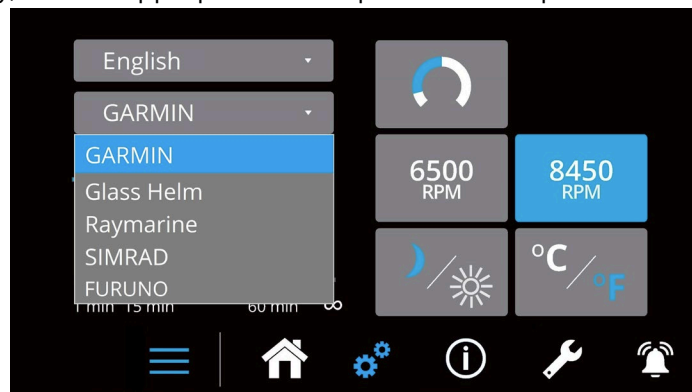

Pressing and holding Settings button  for 5 seconds will show Seakeeper ID (for multiple Seakeeper installations) and IP address.

PRODUCT SEAKEEPER SERIES MODELS

MFD Integration

Step 5 continued

- b. On ConnectBox, **CYCLE** between HTML settings by holding down Ethernet/Connectivity button for 10 seconds or until spool bar LEDs strobe right to left or left to right.
- c. **IF** mode fails to switch, **THEN REPEAT** Step 5.b.

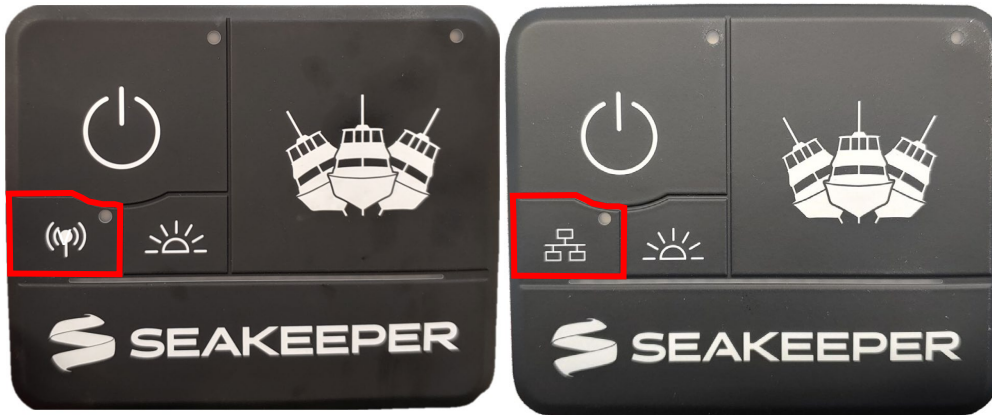

ConnectBox software **3.0.4-de5310b9**, and after, has only two synchronization modes for MFD connectivity:

- 1) DHCP server function off (for Garmin, Raymarine, and Furuno MFDs) indicated by spool bar strobing from right to left.
- 2) DHCP server function on (for NAVICO brand MFDs) indicated by spool bar strobing from left to right.

NOTE:

- It is recommended that MFD be powered before cycling Seakeeper power.
- Multiple power cycles may be required before Seakeeper icon populates on MFD list of connected components.

6. **CYCLE** DC control power to Seakeeper.

PRODUCT SEAKEEPER SERIES MODELS

MFD Integration

7. Except for ConnectBox NMEA backbone connection, **ENSURE** Seakeeper CAN is not connected to a NMEA2000 backbone.

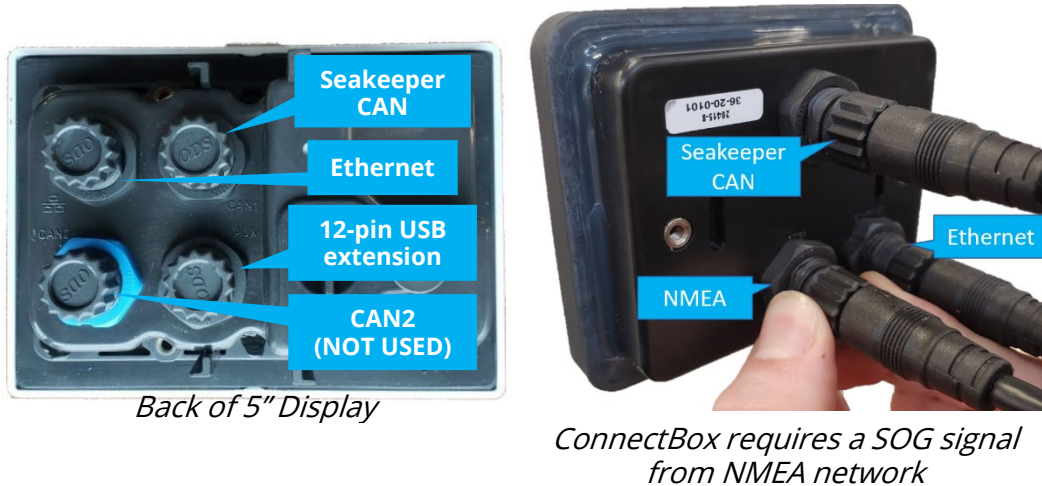

8. **IF** 5" Display/ConnectBox connected to MFD via network expansion hub,
THEN:
- BYPASS** network hub.
 - CONNECT** compatibility cable from Seakeeper 5" Display or ConnectBox to MFD.
 - IF** bypassing network hub resolves compatibility issues,
THEN DIRECTLY CONNECT Seakeeper to MFD if possible.

NOTE:

Seakeeper is not responsible for supporting network hub troubleshooting.

- IF** network hub is required by MFD,
THEN CONTACT network installer or MFD manufacturer for additional support.
9. **ENSURE** Seakeeper app appears on MFD list of connected ethernet / HTML devices.
10. **CHECK** flywheel speed is same RPM at 5" Display and on MFD app.



PRODUCT SEAKEEPER SERIES MODELS

MFD Integration

11. **IF** MFD integration issues persist,
THEN CONTACT Seakeeper Product Support Team at support@seakeeper.com with following:
 - a. Make and model of MFD and software version
 - b. Any error messages on MFD
 - c. Seakeeper interface installed (5" Display or ConnectBox) and software version
 - d. Notes of all actions taken
 - e. Whether Seakeeper app appears on MFD and how it appears (icon visible or not?)

******* END *******

ATTACHMENT: ADDITIONAL TROUBLESHOOTING EXPERIENCE

The attachment is intended to provide a summary of example cases and lessons learned for MFD troubleshooting.

1. **General rules of thumb for MFD compatibility:**
 - a. Garmin OneHelm™ is required to support Seakeeper compatibility. [[OneHelm™](#) is a software feature available on certain Garmin models]
 - b. All Raymarine Axiom® models support Seakeeper compatibility.
 - c. Furuno NavNet™ is required for Seakeeper compatibility.
2. **Furuno and ConnectBox compatibility:** Furuno MFDs do not support Seakeeper ConnectBox until NavNet™ TZT3, version 3.5, released in October 2022.
3. **Garmin power-up sequence:**
 - a. When operating with Garmin MFD, MFD should be powered up before powering Seakeeper to ensure the two systems communicate correctly.
 - b. For Garmin compatibility, Seakeeper 5" Display or ConnectBox rely on Garmin MFD to act as DHCP Server, which provides an IP address to Seakeeper device.
 - c. If Seakeeper powered up first, it would look for IP Address from Garmin MFD; however, if there is a significant delay between when Seakeeper and Garmin power up, Seakeeper can fail to secure an IP address resulting in a OneHelm error. If this occurs, cycle Seakeeper power and app should load on Garmin MFD.
4. **Raymarine and ConnectBox compatibility:** Early Seakeeper ConnectBox software versions were found to be incompatible with Raymarine MFDs. Incompatibility in these cases can be remedied by updating ConnectBox software per [TB-90555 – Display Software Compatibility](#).
5. **NAVICO and multiple Seakeepers with ConnectBox:** If Seakeeper with ID #1 is not available, other Seakeepers may not be available in app. Re-designate another Seakeeper as ID #1 in this case.
6. **GARMIN software version 20.0:** This revision of Garmin software does not communicate with Seakeeper displays or ConnectBox user interfaces. Garmin devices with his revision must be updated.



PRODUCT SEAKEEPER SERIES MODELS

WIRE HARNESS SCHEMATICS



Seakeeper Series model simplified wire harness schematics are numerically ordered by model number. One model line may have several iterations; note the serial range applicable to the serviced model.

SEAKEEPER 2

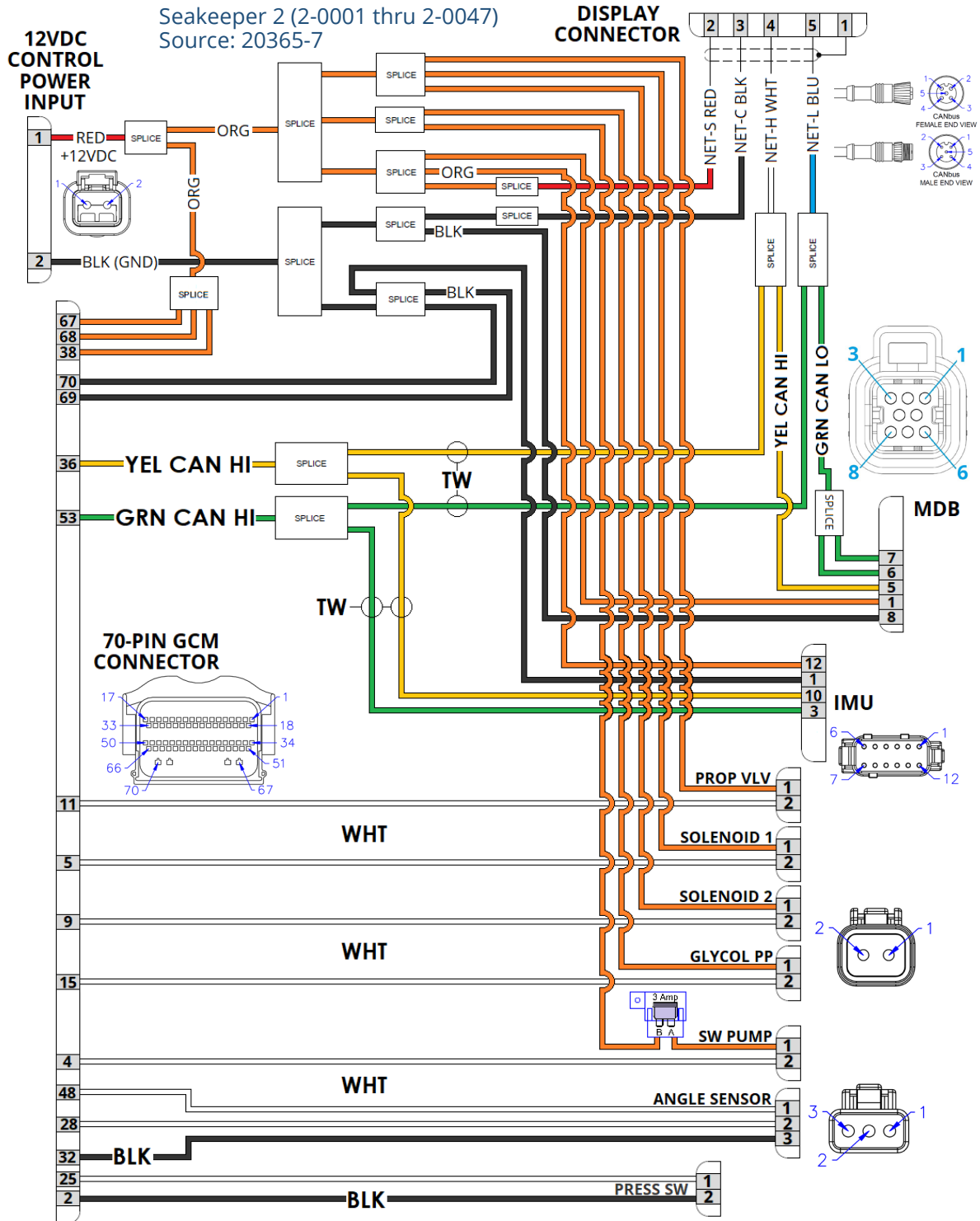

SEAKEEPER 2

Seakeeper 2 (2-0048 thru 2-0399)
Source: 20365-8

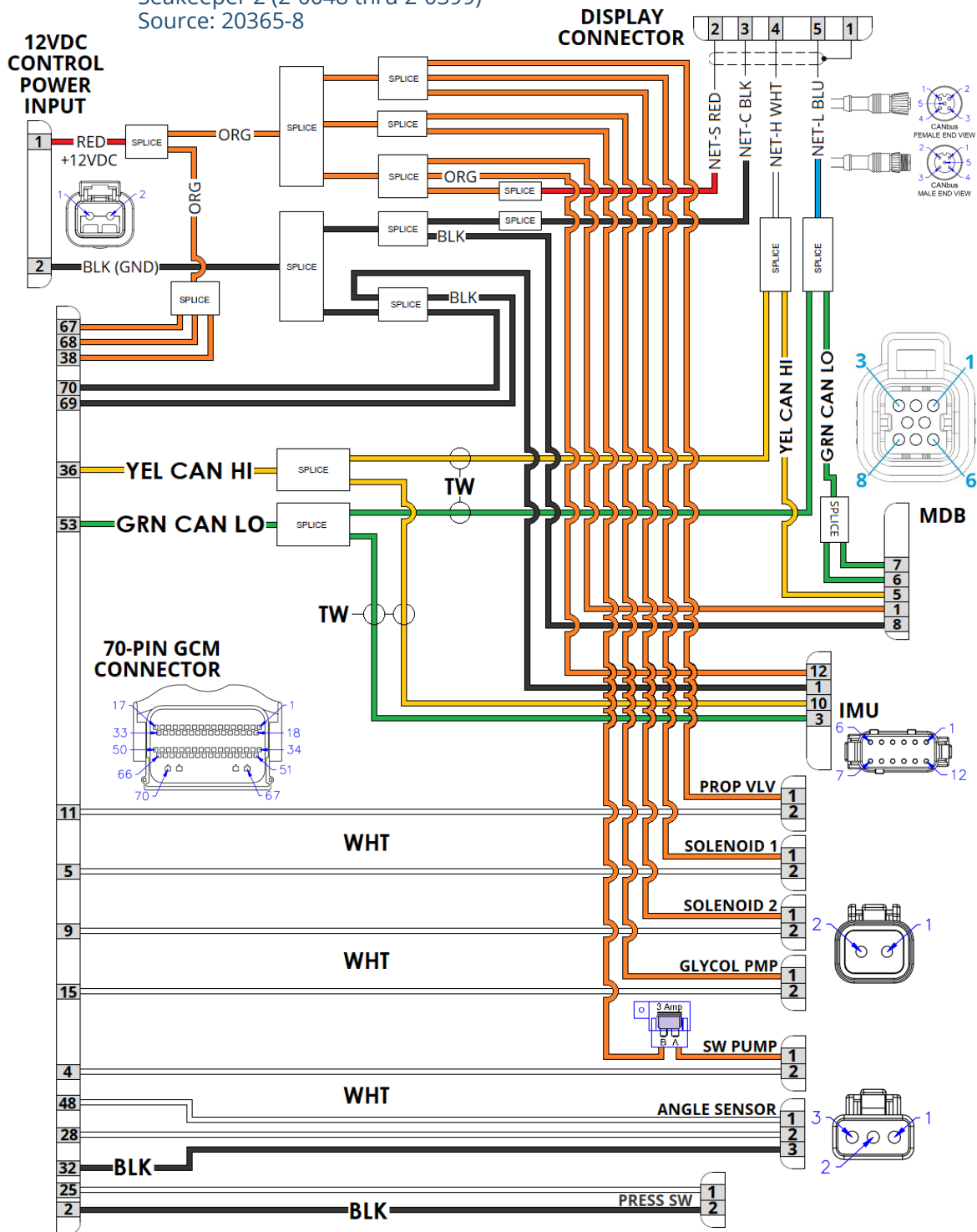

SEAKEEPER TROUBLESHOOTING GUIDE - 106



PRODUCT SEAKEEPER SERIES MODELS

SEAKEEPER 2

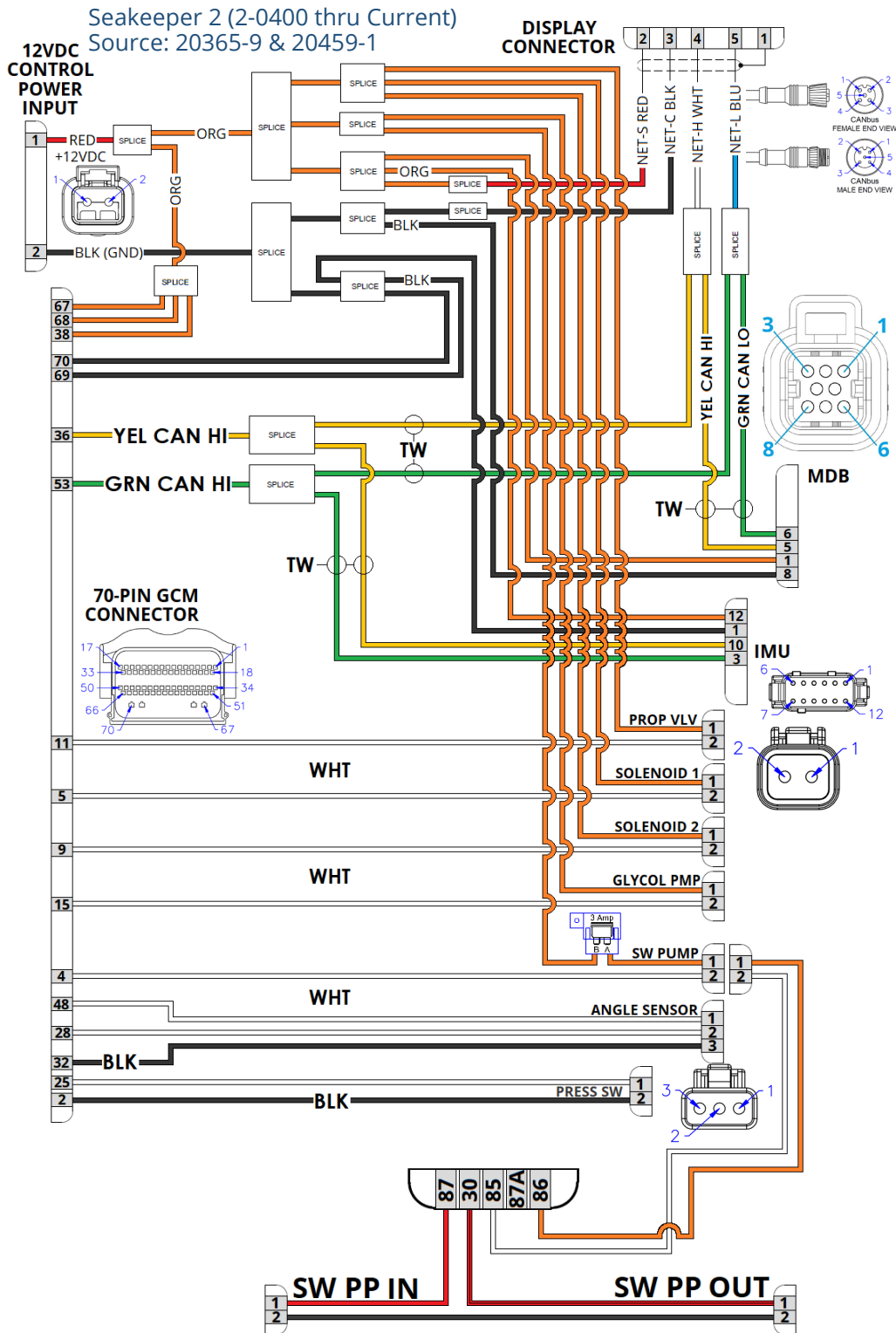

SEAKEEPER TROUBLESHOOTING GUIDE - 106



PRODUCT SEAKEEPER SERIES MODELS

SEAKEEPER 3

Seakeeper 3 (3-0001 thru 3-0441)

Source: 20273-4

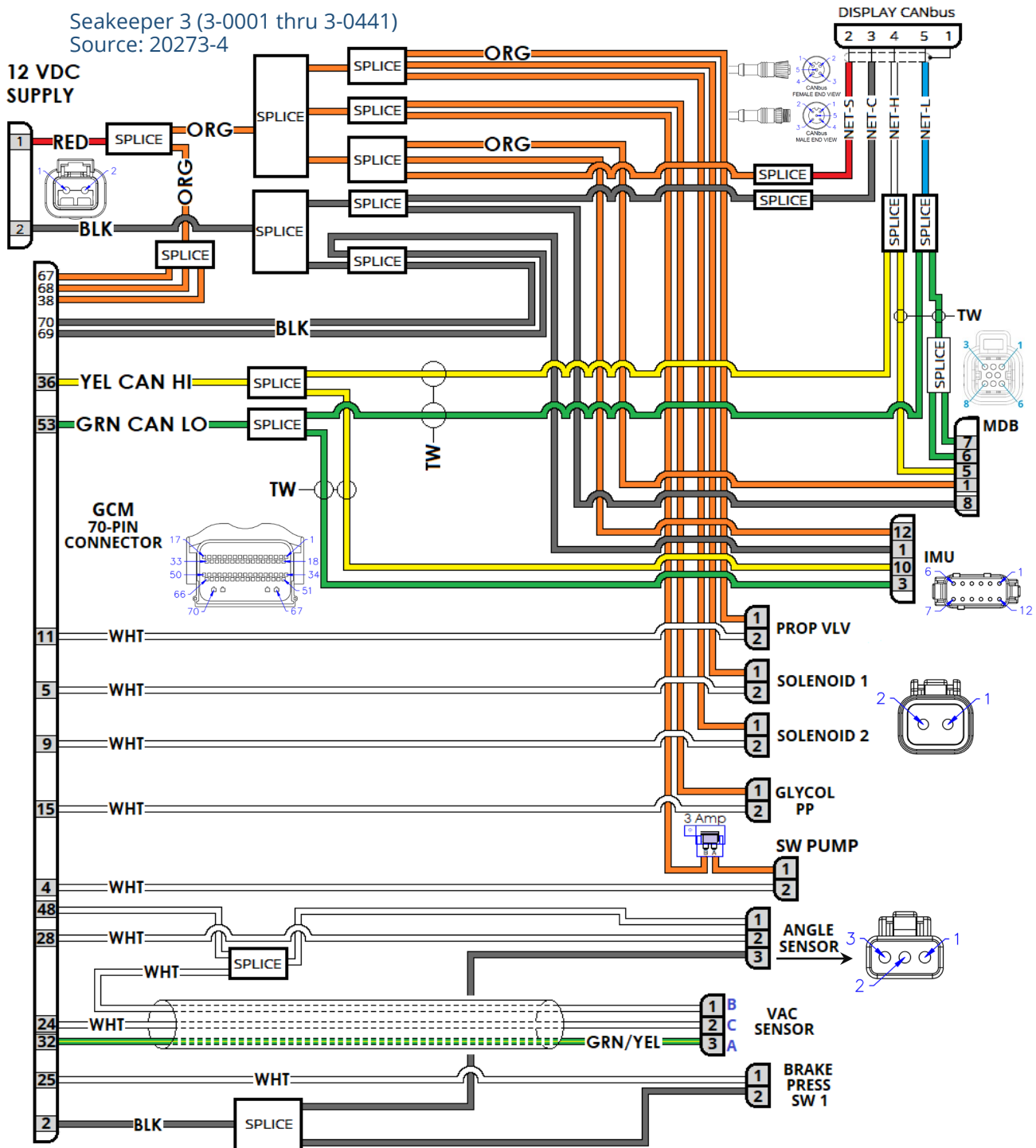

SEAKEEPER 3

Seakeeper 3 (3-0442 thru 3-1424)
Source: 20273-6

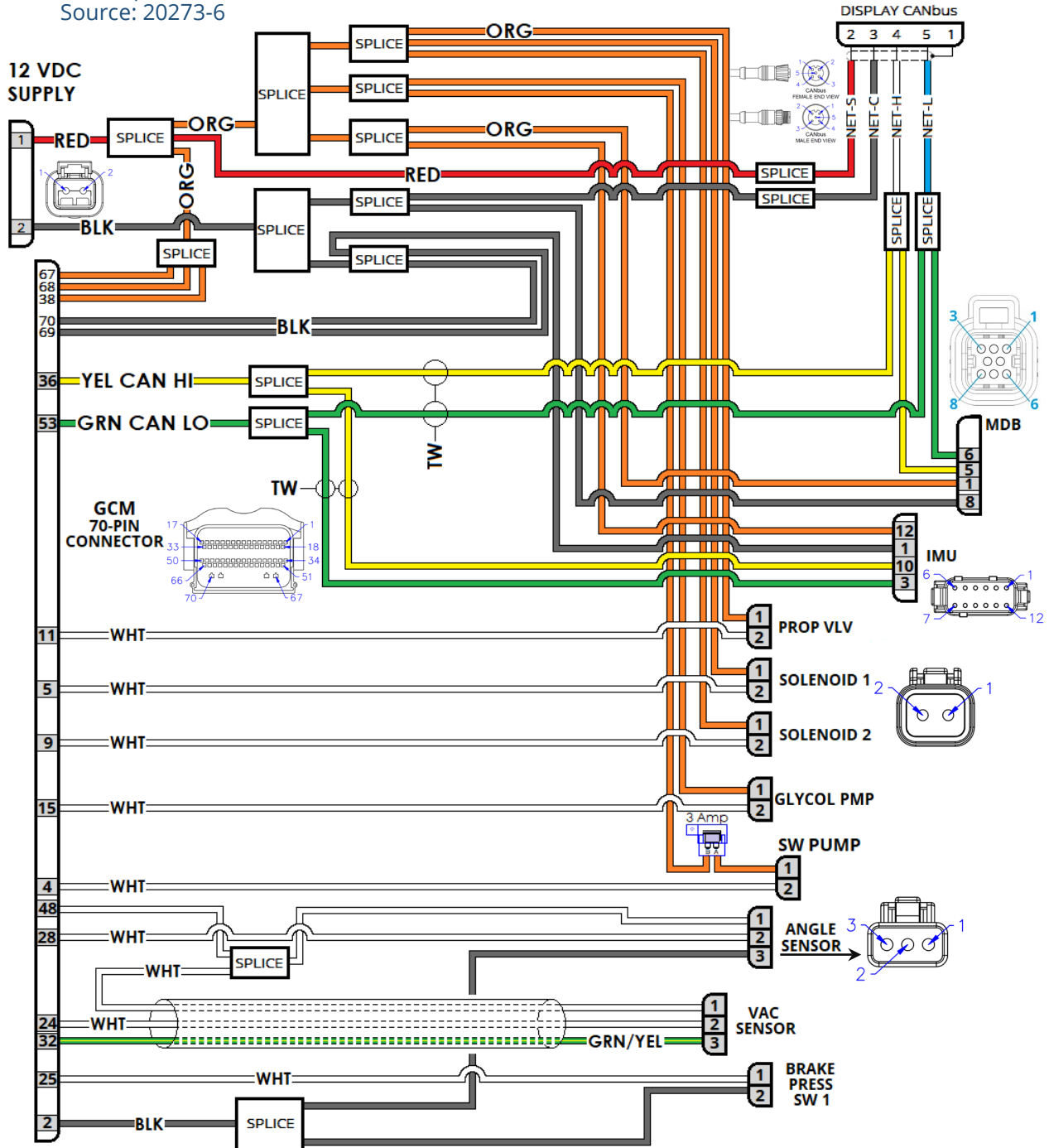

SEAKEEPER 3

Seakeeper 3 (3-1425 thru Current)
Source: 20273-7 & 20459-1

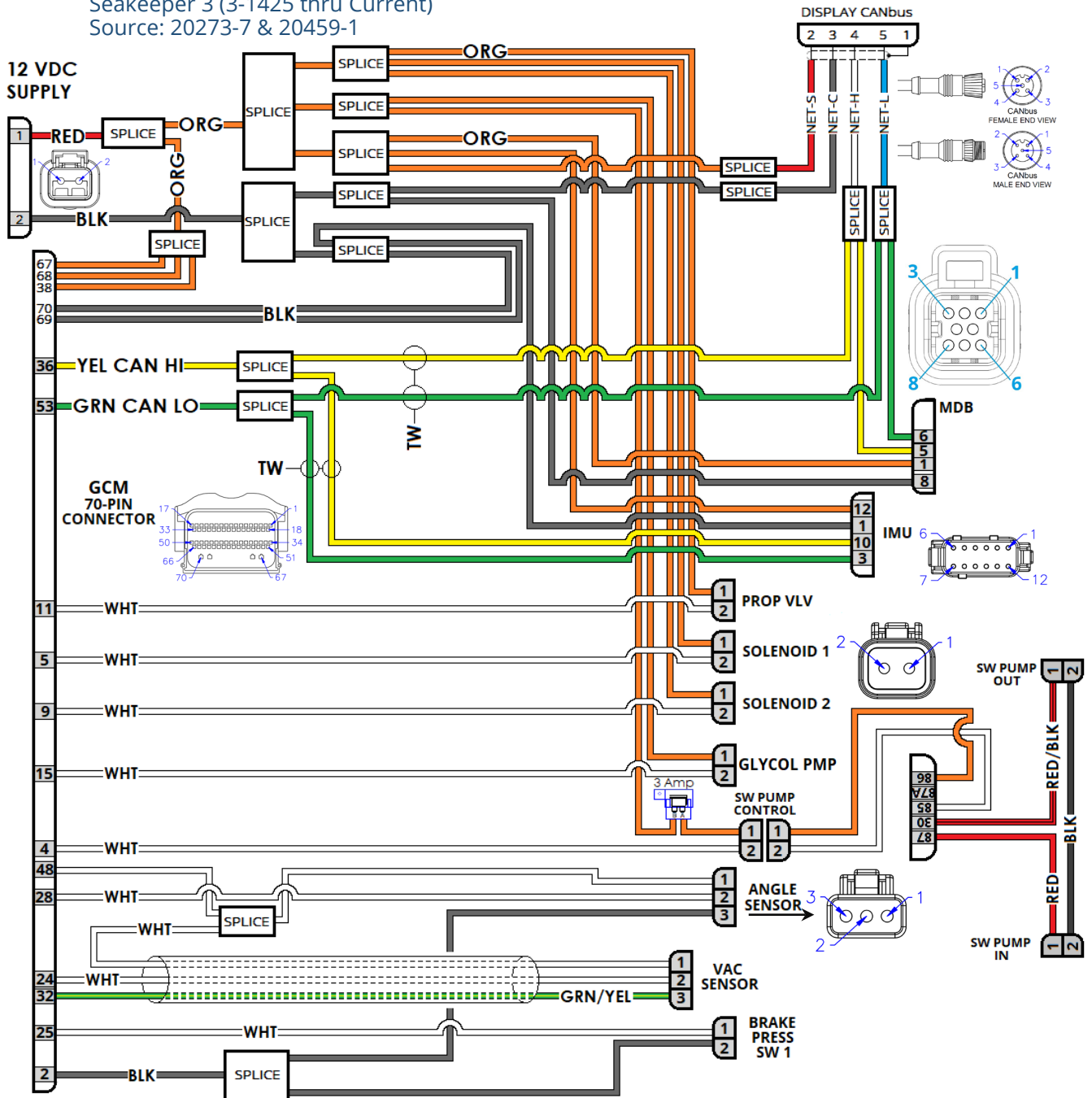

SEAKEEPER 5/3DC (EM)

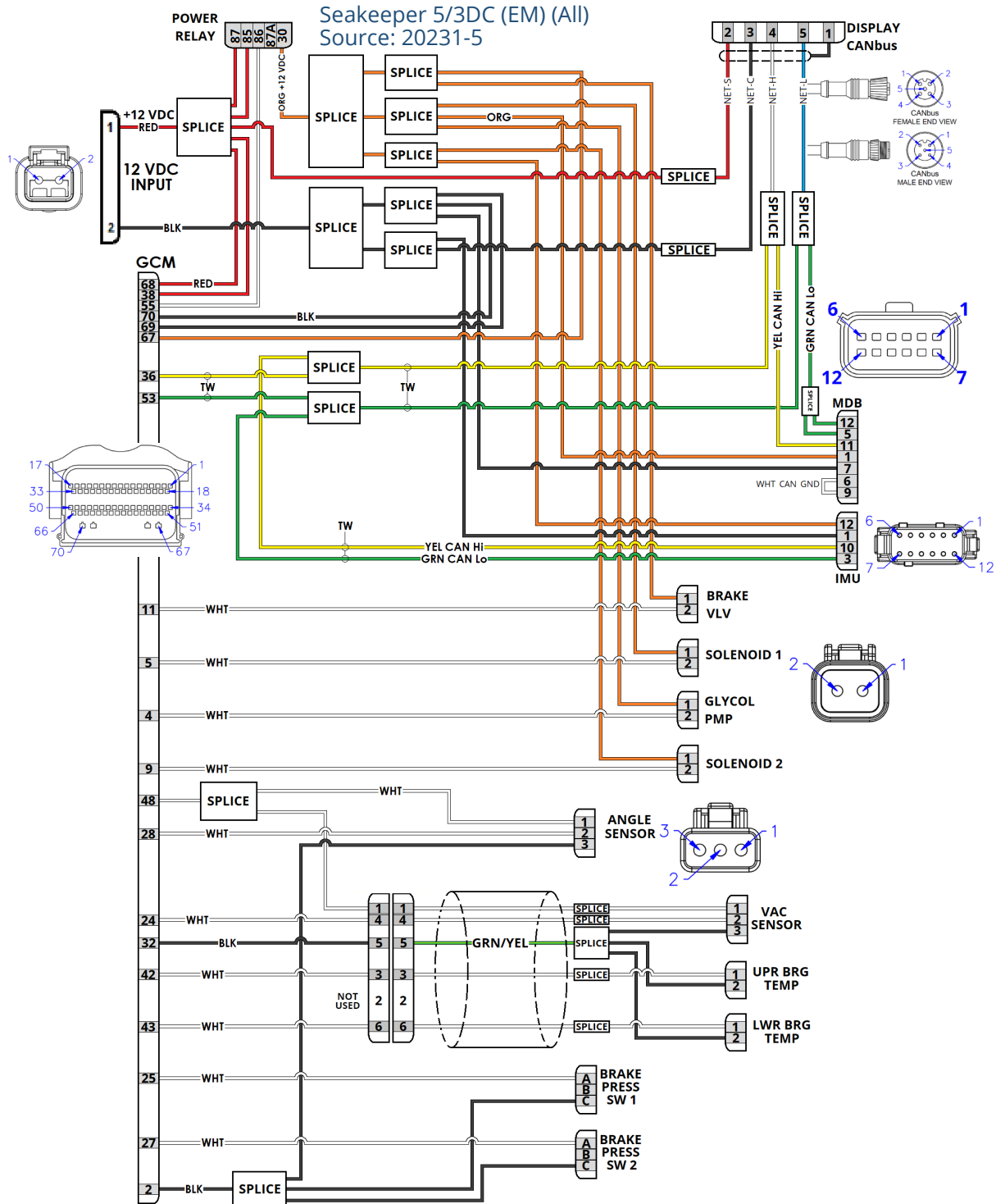

SEAKEEPER 6/5

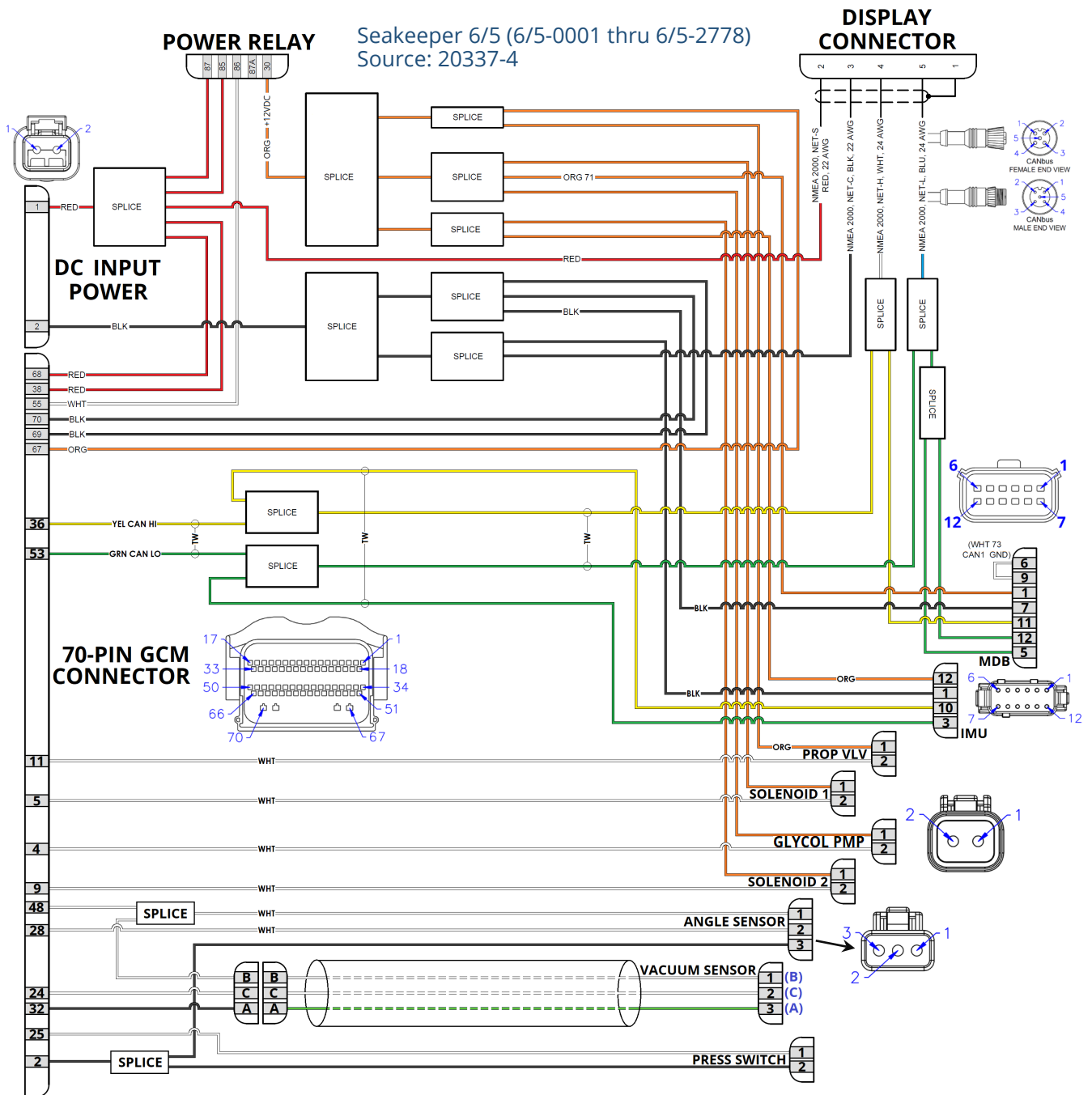

SEAKEEPER 6/5

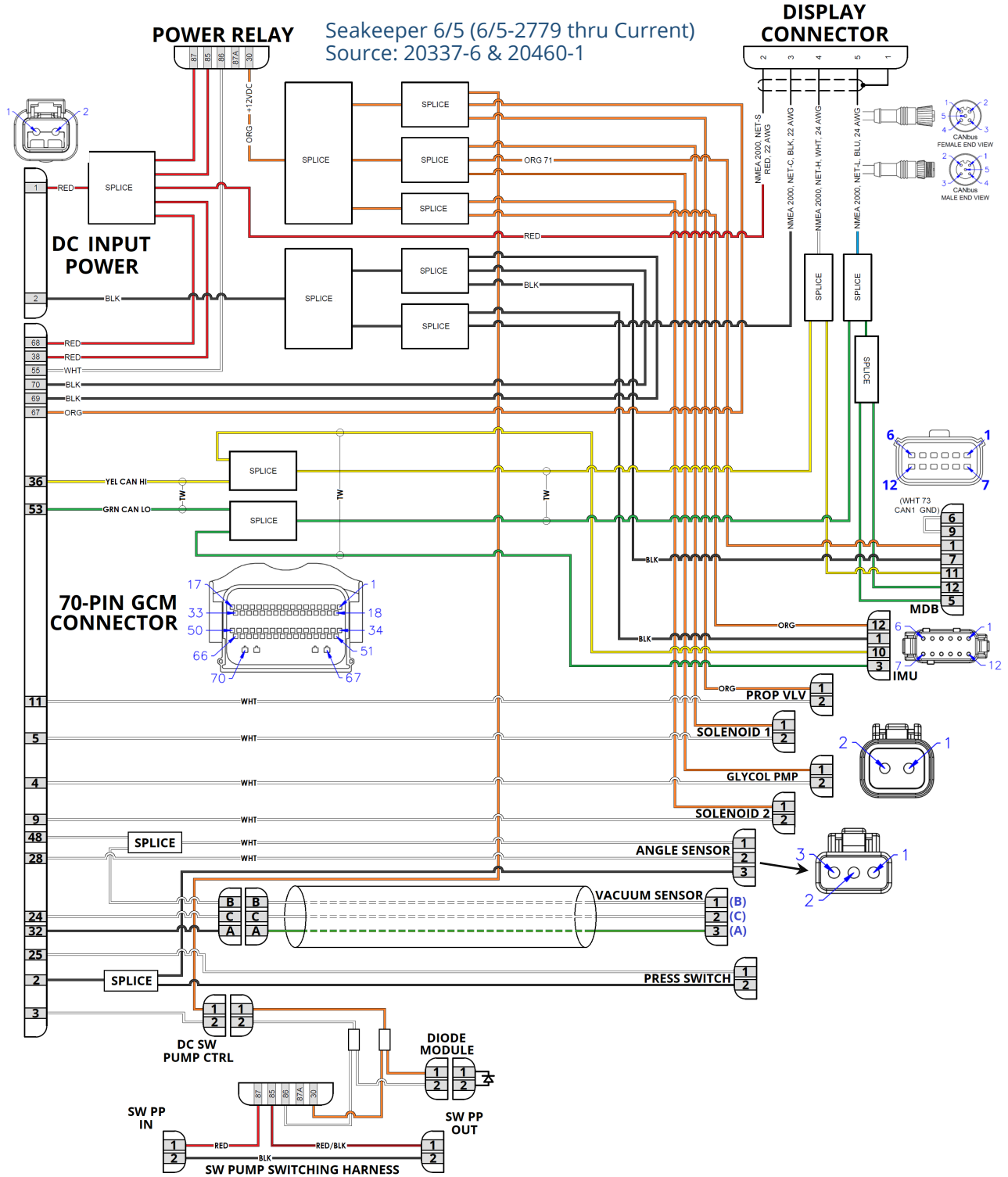

SEAKEEPER 9

Seakeeper 9 (9-0001 thru 9-1369)
Source: 20218-7

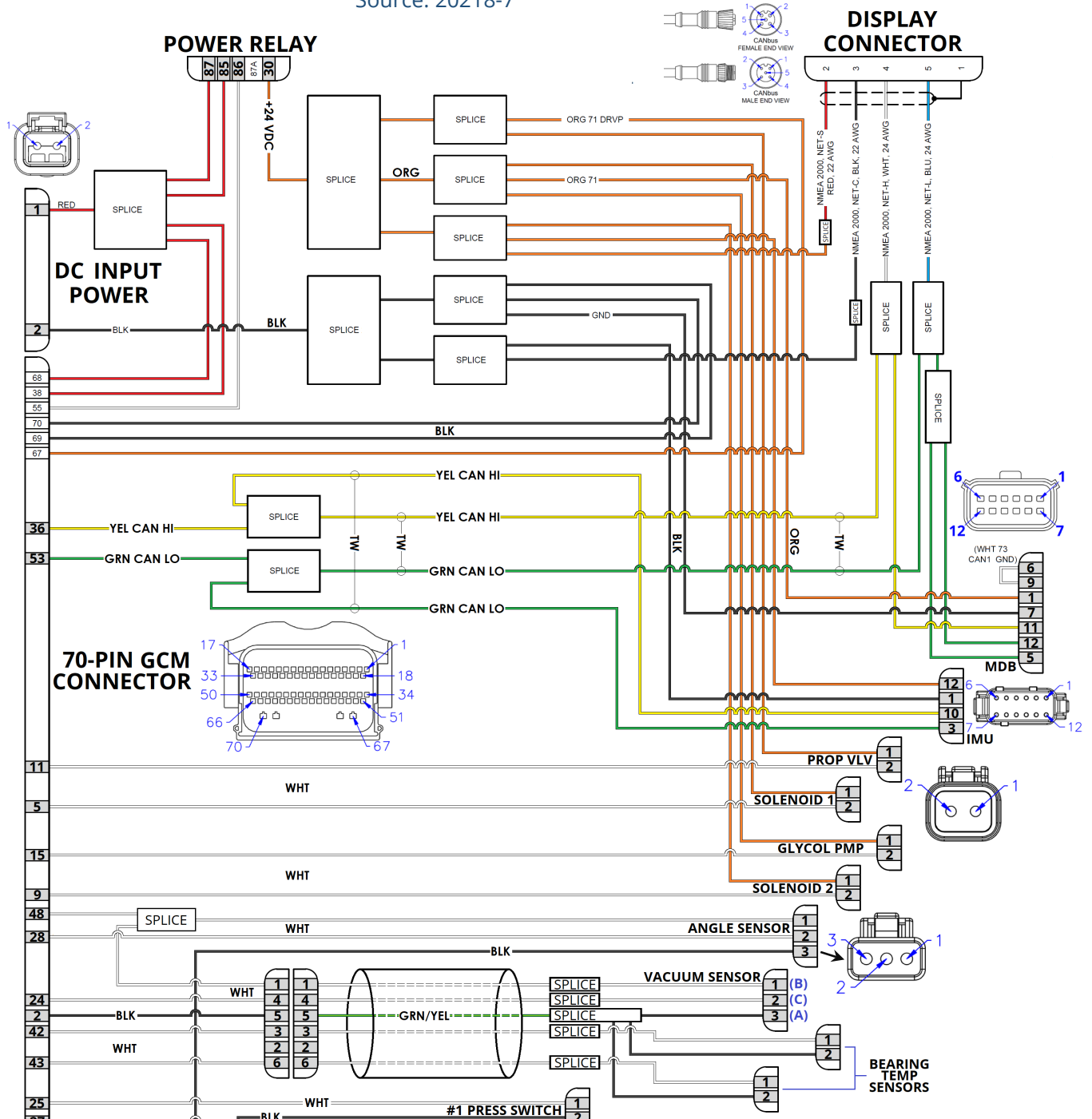

SEAKEEPER 9

POWER RELAY

Seakeeper 9 (9-1370 thru 9-2838)
Source: 20218-10

DISPLAY CONNECTOR

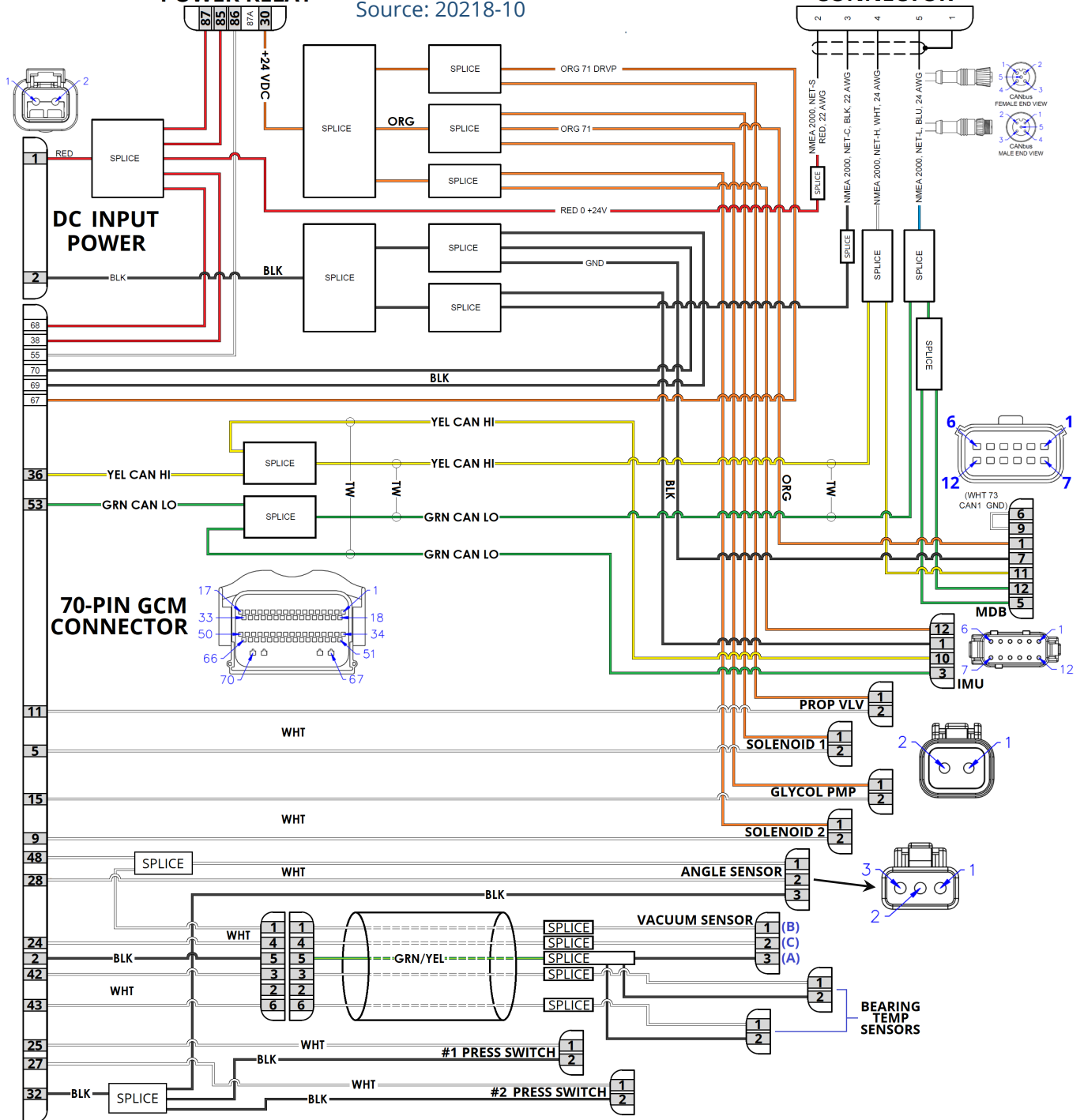

SEAKEEPER 9

Seakeeper 9 (9-2839 thru Current)
Source: 20445-3 & 20440-1

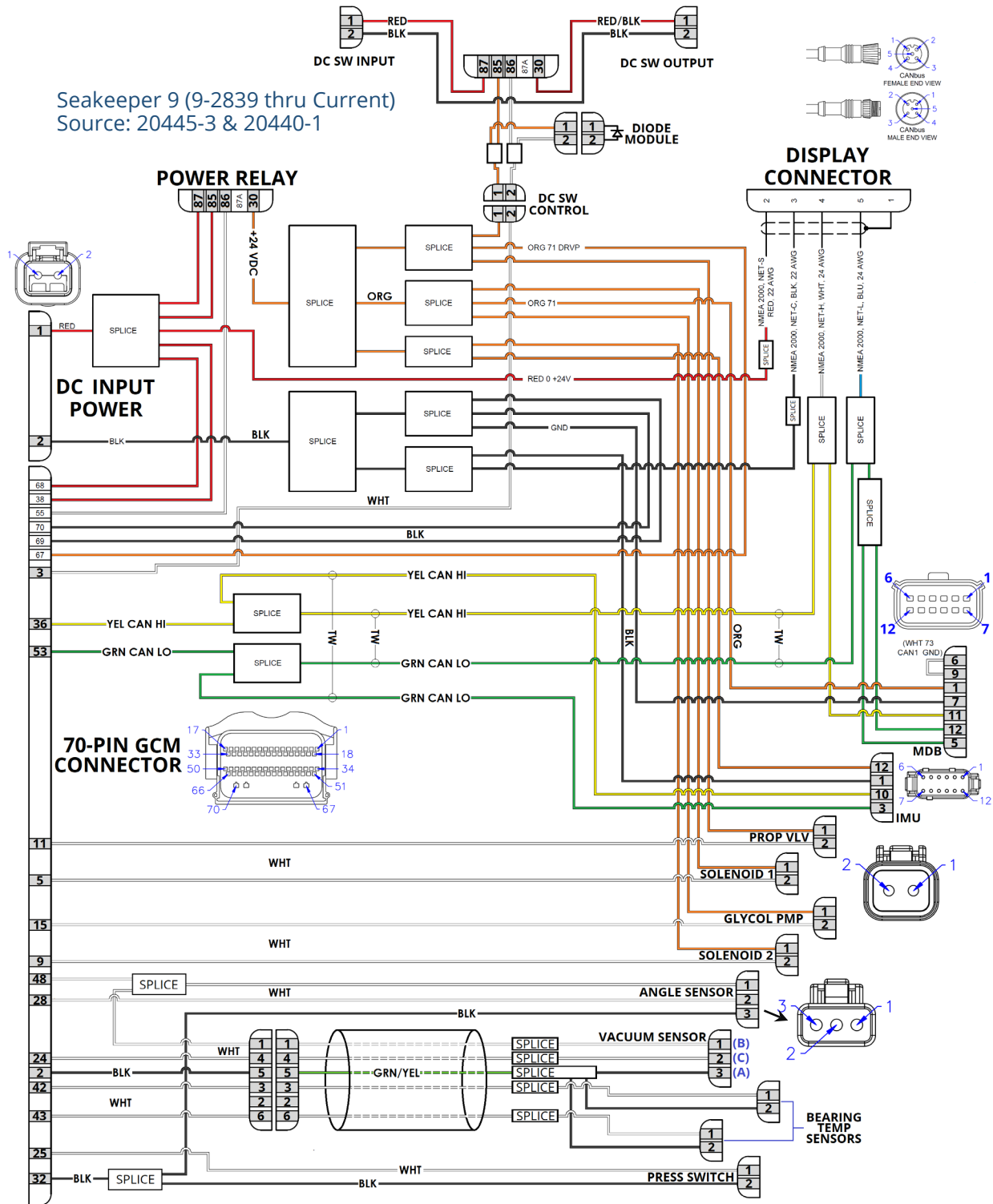

SEAKEEPER 16 (EM)

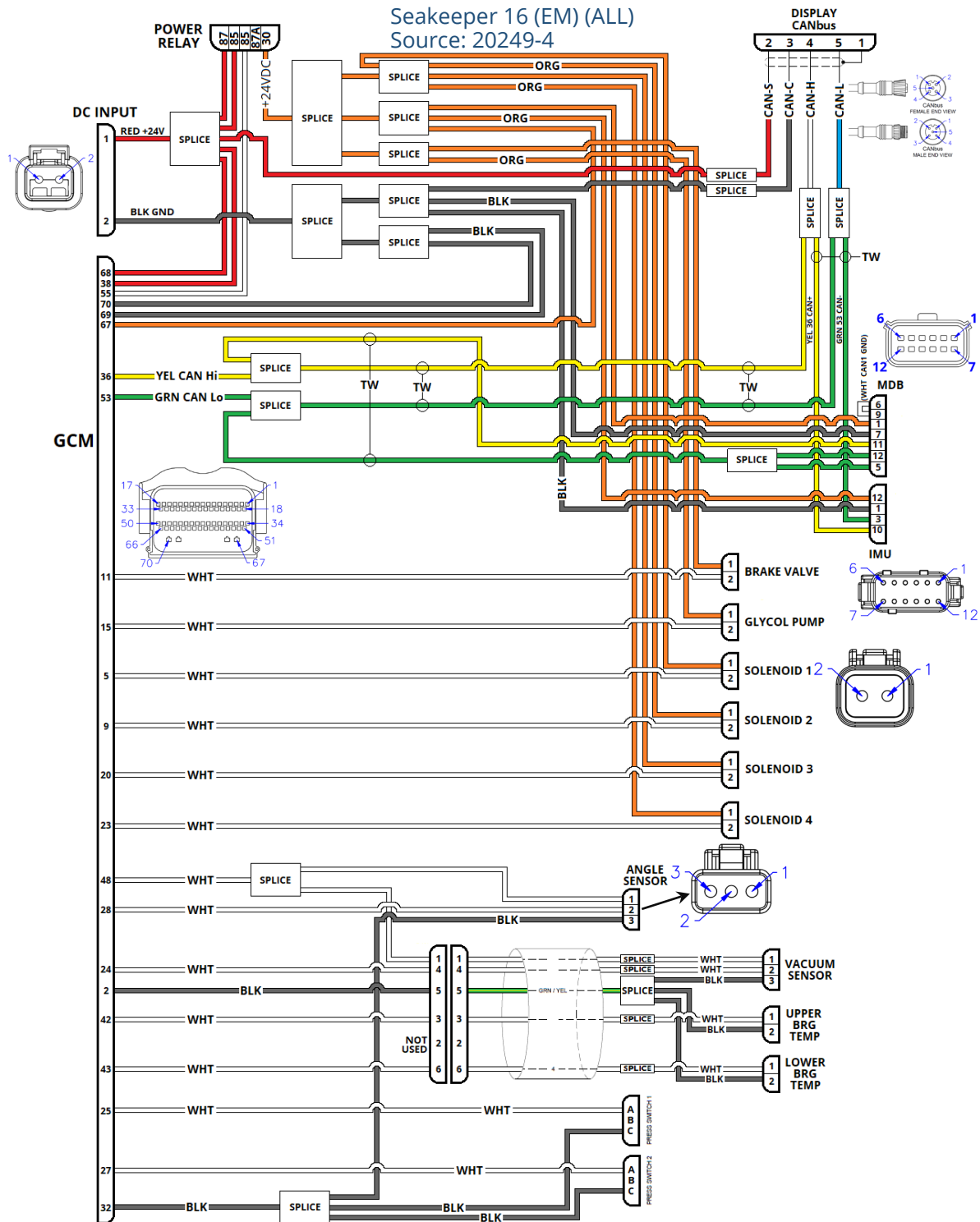

SEAKEEPER 16/18

Seakeeper 16 / 18 (ALL)
Source: 20446-7

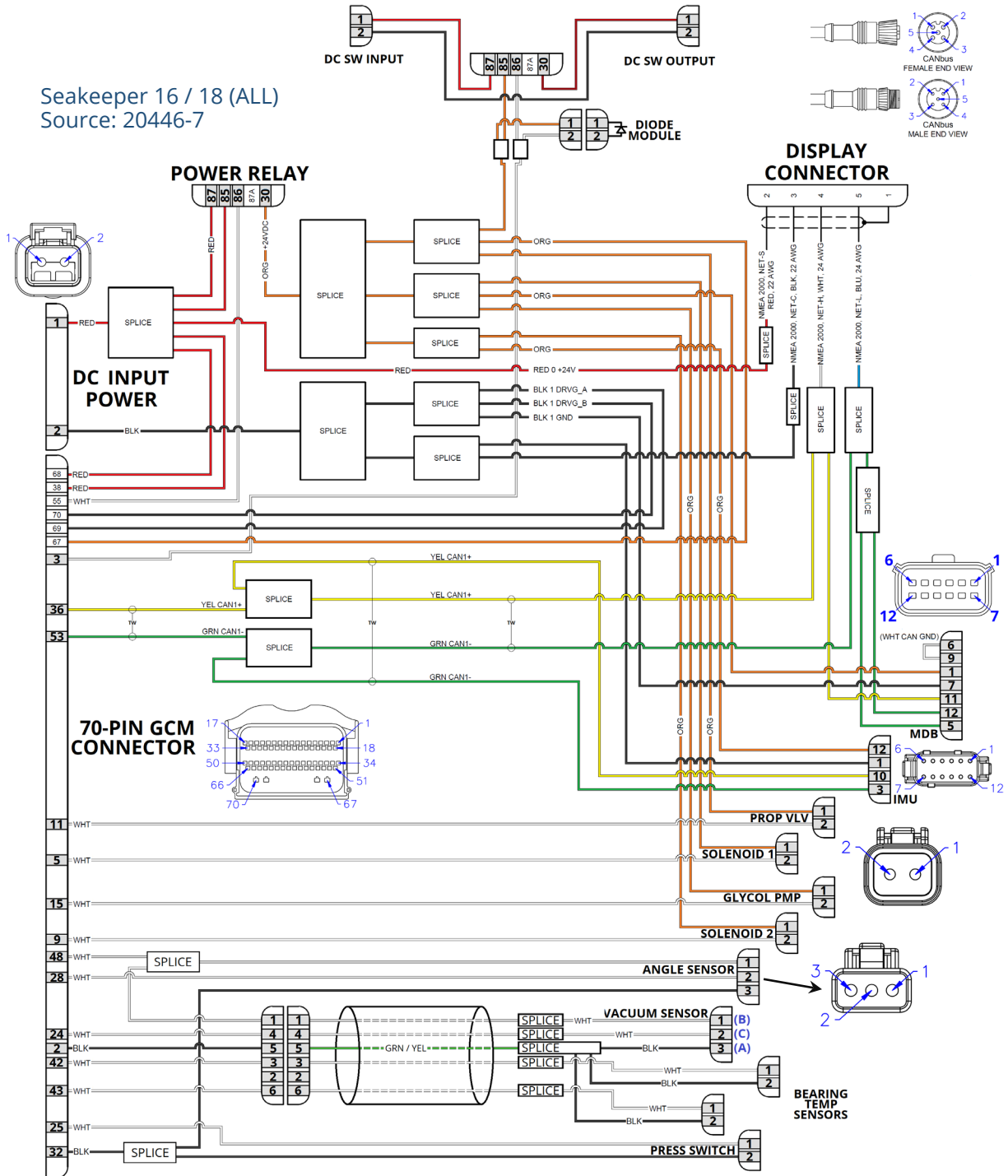



PRODUCT SEAKEEPER SERIES MODELS

SEAKEEPER 26 & 35

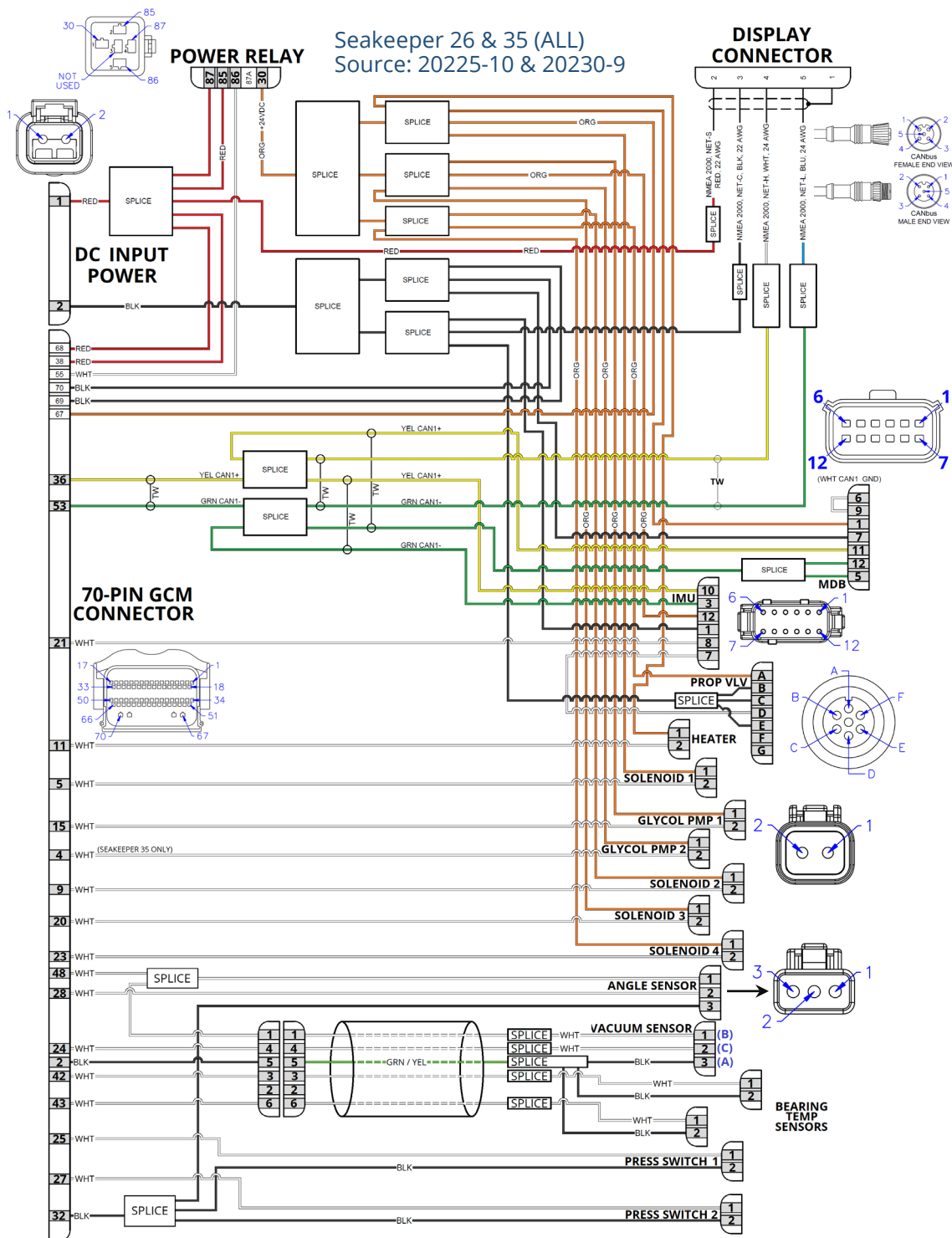

SEAKEEPER 40

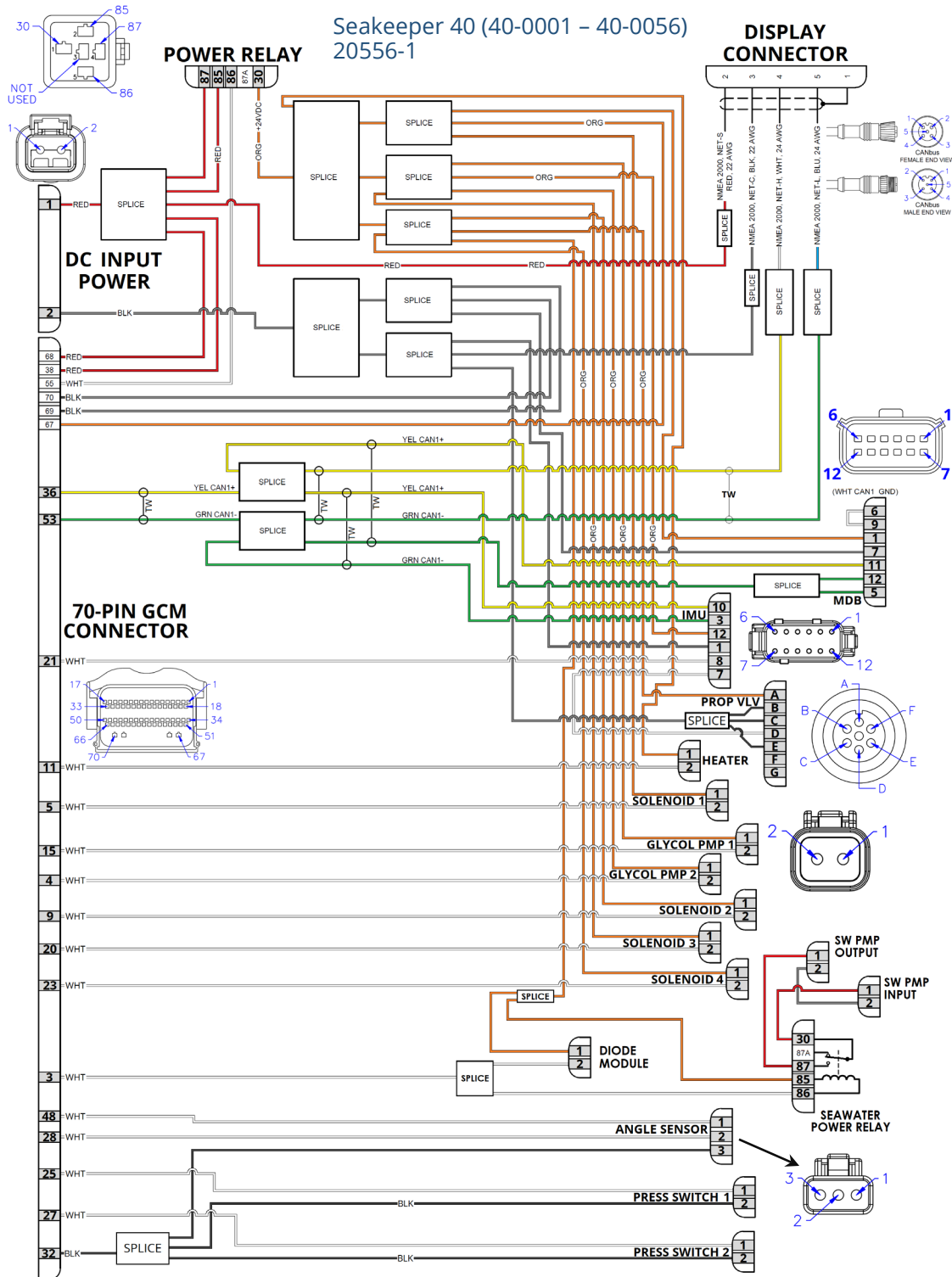

SEAKEEPER 40

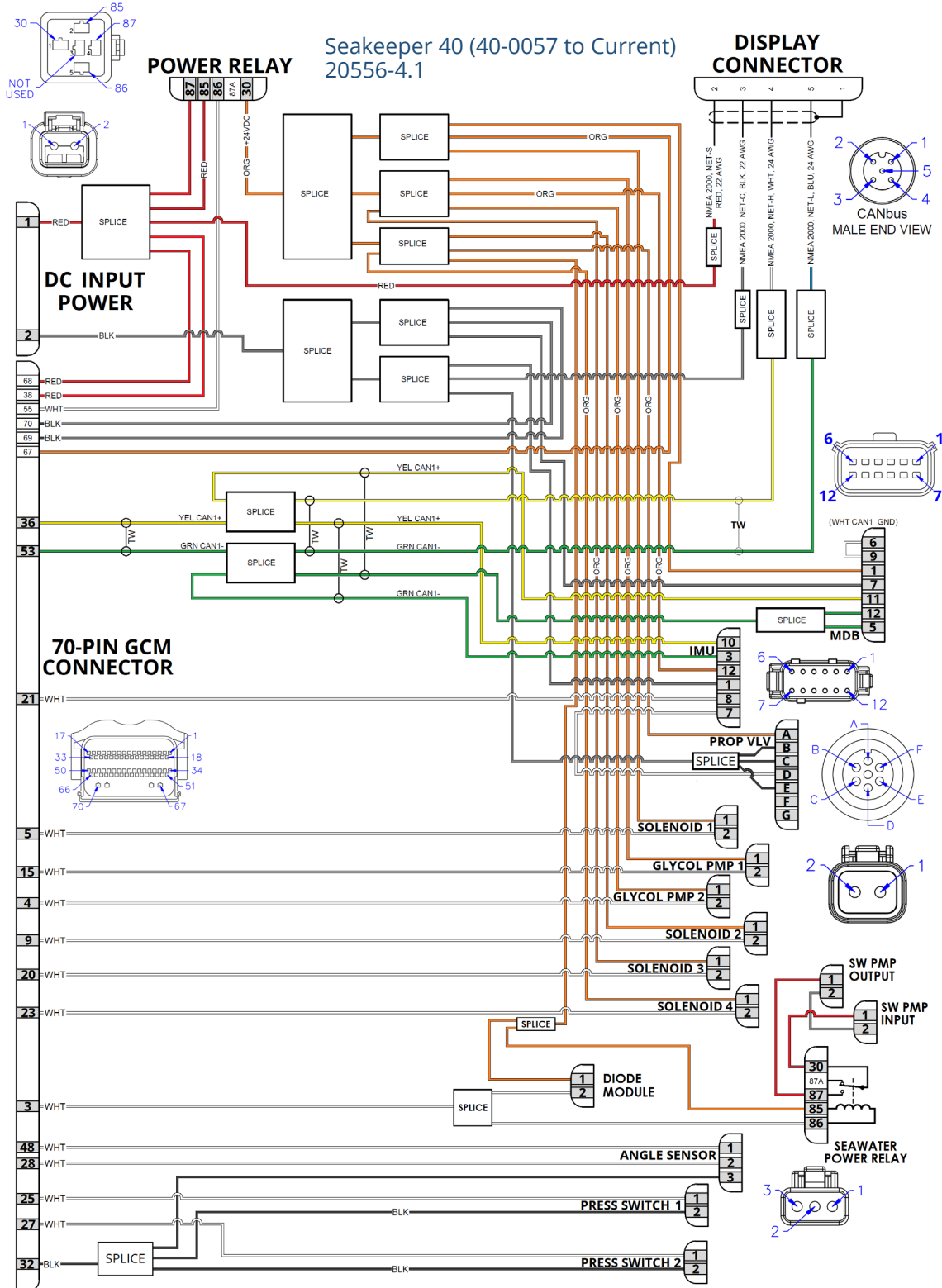

CODE 1/19/50/55/56/106 △

To troubleshoot and repair the

- "ANGLE SENSOR CALIBRATION REQUIRED" (Code 1) (Seakeeper 2, 3, 5, and 6)
- "ANGLE SENSOR FAULT – ACTIVE RANGE HIGH" (Code 19)
- "ANGLE SENSOR FAULT – ACTIVE RANGE LOW" (Code 55)
- "ANGLE SENSOR FAULT" (Code 50)
- "ANGLE SENSOR FAULT – UNRESPONSIVE" alarms (Code 56) (Seakeeper 2 & 3)
- "ANGLE SENSOR FAULT" (Code 106)

BACKGROUND

Continued operation with any of these codes may damage equipment or cause injury. **Power to the Seakeeper must be cycled to reset these alarms** (except Code 1).

The Angle Sensor Fault – Active Range High or Low (Codes 19 & 55) occurs if the angle sensor's output voltage signal goes higher or lower than expected. The expected voltage range is 0.5 to 4.5VDC between the angle sensor's signal output and the ground. Less than 0.5VDC corresponds to an angle less than -80° (much further than physically possible by the enclosure). Likely causes are a loose or incorrectly mounted sensor, a Sensor Power High or Low alarm condition (Codes 44 & 45, respectively), an unplugged, damaged, or miswired sensor, or a wire harness issue from the controller to the sensor. A brake issue that causes the enclosure to hit the end stop may cause this fault (if it jars hard enough) but would also likely trigger motion/travel or pressure faults to indicate a brake issue.

If a Code 44 or 45 accompanies a Code 19 or 55, troubleshoot the sensor voltage per the Code 44/45 Troubleshooting Guide first. Correcting the sensor voltage issue should correct the Angle Sensor Fault – Active Range High or Low.

The Angle Sensor Fault [Out of Range] (Code 50) occurs when the gimbal angle sensor transmits a signal greater than the specific model's programmed precession angle limit. It could also mean a brake issue causing the Seakeeper to hit the end stops, which would throw other motion or brake low-pressure alarms.

The Angle Sensor Fault – Unresponsive alarm (Code 56) occurs when the sensor ground wire is opened in Seakeeper 2 and 3 models. The probable cause is an open loop on the ground wire, either in the sensor leads or in the wire harness.

Code 1 is enabled on Seakeeper 2, 3, 5, and 6. The code informs the operator that the Seakeeper programming detects the need for a simplified calibration procedure explained in SWI-108A. This software logic may only appear on models built before autumn 2023 if the GCM software has been updated.

If Code 1 is received on a Seakeeper equipped with a 3.5" display and GCM software versions 11.100 through 11.130, the alarm will appear as "CODE 1 – BEARING TEMP HIGH" when it is an angle sensor calibration-required code. Correct this alarm by performing SWI-108A.

REFERENCES

Applicable Seakeeper Service Drawings on [Dealer Access](#)

[TB-90615 - Angle Sensor Unresponsive Alarm 56 technical bulletin \(Seakeeper 2/3\)](#)

[SWI-108/108A - Seakeeper Angle Sensor Calibration instruction](#)

[SWI-103 - Seakeeper Brake Service instruction](#)

PRECAUTIONS

See [PRECAUTIONS](#) section of Introduction.

PROCEDURE

1. **IF** Code 1,
THEN:
 - a. **PERFORM** [SWI-108A, Seakeeper Angle Sensor Calibration](#).
 - b. **IF** angle sensor calibration fails to clear Code 1,
THEN PERFORM [steps 20 through 23](#) to check wiring and connectors of angle sensor lead and wire harness.
2. **IF** Code 56,
THEN:
 - a. **OBTAIN** photo of information screen.
 - b. **PERFORM** [steps 17 through 23](#).
 - c. **SUBMIT** photo and test data collected to Seakeeper Product Support Team at support@seakeeper.com for guidance.
3. **ENSURE** angle sensor connector and GCM 70-pin connectors are made securely.
4. **ENSURE** Seakeeper electrical connections made correctly and securely at angle sensor, manifold solenoids and manifold proportional valve.

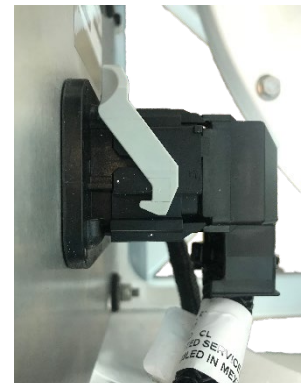

This Seakeeper 6 was installed with "BRAKE VALVE" connector in "SOLENOID 1" connection. Results were multiple travel faults and Code 50's and 55's.

5. **ENSURE** Seakeeper brake hoses are routed per applicable drawing on [Dealer Access](#) website for model in question.

NOTE:

Sensor may be mounted upside down; this is by design in some models. See applicable Seakeeper Service Drawings or SWI-108 attachment for correct orientation of sensor.

- 6. **ENSURE** angle sensor installation is flat against foundation and securely fastened.
- 7. **ENSURE** angle sensor mounted with silver manufacturer's label facing away from Seakeeper.

This notch should be in same orientation as sensor's lead.

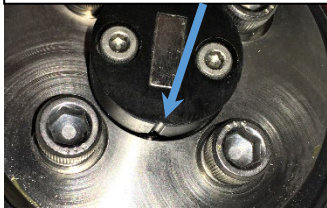

- 8. **IF** installation or electrical connection issue is found, **THEN:**
 - a. **CORRECT** issue
 - b. **PERFORM** angle sensor calibration per [SWI-108/108A](#), Seakeeper Angle Sensor Calibration instruction.

NOTE:

If spare display not available, a second person is needed to minimize trips to display multiple times.

- 9. **DISCONNECT** helm display at Seakeeper **AND INSTALL** spare display locally at Seakeeper, if available.
- 10. **ACTIVATE** brake override.

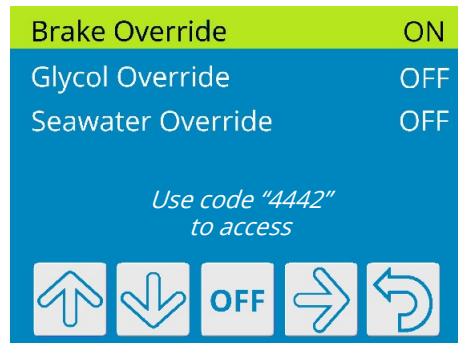
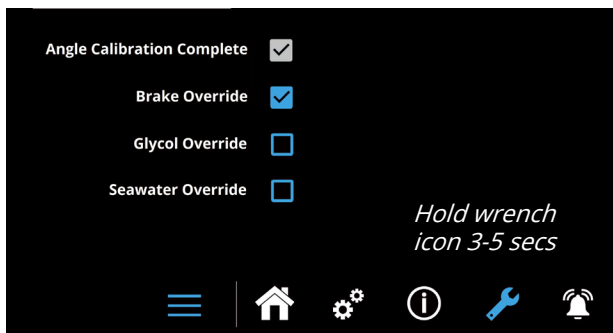

11. **MANUALLY PRECESS** enclosure fully one direction and then in opposite direction.
12. **NOTE** angle readings at full travel in each direction.

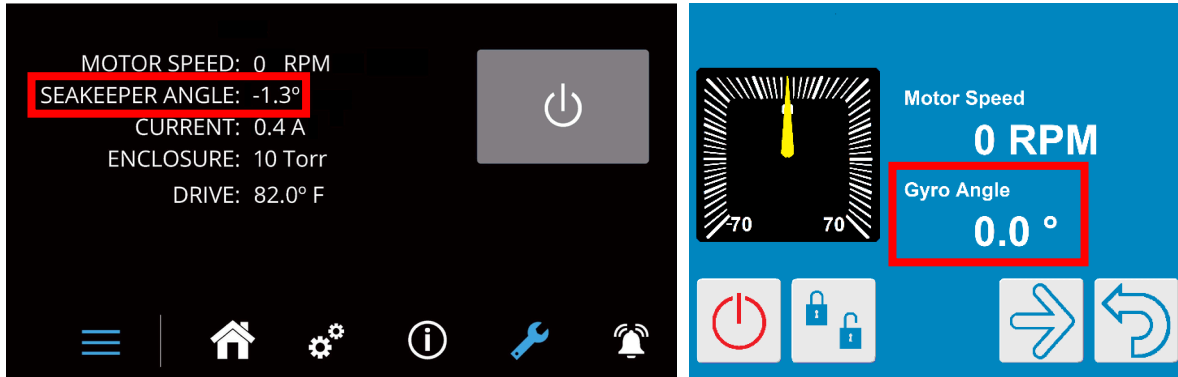

13. **IF** two angles are **NOT** in alignment per table below, **THEN PERFORM** gimbal angle sensor calibration per [SWI-108](#), Seakeeper Angle Sensor Calibration instruction.

NOTE: The maximum angles displayed should be $\pm 3.0^\circ$ from end stops ($\pm 2.0^\circ$ for Seakeeper 3). The two extremes (full forward and full aft) should be within 1.0° of each other, absolute value.

For example, Seakeeper 2 enclosure reads $+70.1^\circ$ and -69.8° . The two readings are within 0.1° and 0.2° from 70° and are 0.3° from each other, absolute (within 1.0° from each other); this angle sensor is in calibration.

MODEL	PRECESSION RANGE (\pm)
Seakeeper 2	68°
Seakeeper 3-0001 through 3-194-0957	70°
Seakeeper 3-194-0958 and after	60°
Seakeeper 5/3DC without bump stop	70°
Seakeeper 5/3DC with bump stop	60°
Seakeeper 6/5	60°
Seakeeper 9/7HD	70°
Seakeeper 16/12HD & 18	70°
Seakeeper 26/20HD	60°
Seakeeper 35/30HD/40	70°
M-Series	60°

14. **IF** unable to calibrate angle sensor,
THEN VERIFY permanent magnet attached to gimbal shaft behind angle sensor is attached properly to shaft as follows:

- a. **ENSURE** magnet is unable to move by hand.
- b. **IF** magnet can be moved **AND** is still in shaft groove,
THEN RE-ATTACH magnet with drop of 2-part epoxy.

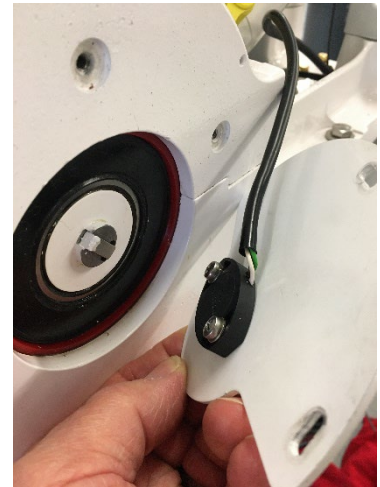
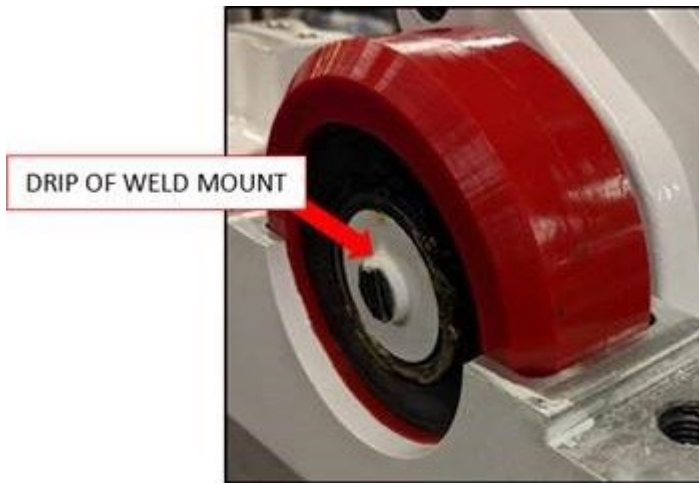

c. **IF** magnet has come loose from shaft and no yellow marking on magnet,
THEN PERFORM following:

NOTE:

Both Android and Apple app stores offer a free *magnetic pole detector* app.

i. With smartphone magnetic pole detector app or pole detection device (shown), **DETERMINE** North pole of magnet by following app or device instructions.



An example of pole detection device in operation with magnet.

ii. **MARK** north pole side of magnet with permanent marker.

Step 14.c continued

- iii. **INSTALL** magnet into shaft with North facing **front** of model.

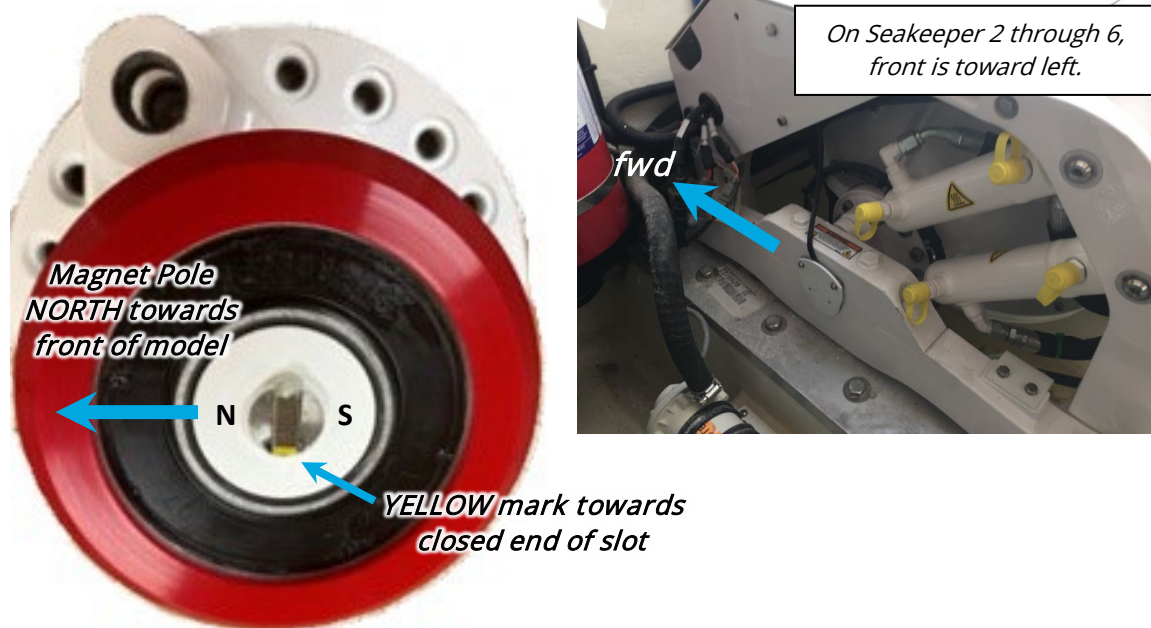

- iv. **REPEAT** step 13 to calibrate angle sensor.

- d. **IF** magnet has a yellow mark on one end,
THEN:

- i. **DETERMINE** North pole of magnet.

- ii. **INSTALL** yellow mark to closed end of slot in gimbal shaft with north pole facing front of Seakeeper.

15. **PERFORM** following electrical checks of angle sensor:

- a. **CONNECT** angle sensor to wire harness.
- b. **ENSURE** low current DC power available to Seakeeper.

Step 15 continued

c. **ENSURE** brake override activated.



NOTE:

Negative precession angle is precession of enclosure in forward direction.

Settings screen orientation button should indicate blue arc on right side of button if Seakeeper facing aft.



TYPICAL GIMBAL ANGLE SENSOR RESPONSE

Signal (volts)	Displayed Angle (deg)
0.25	90
0.75	70
1	60
1.375	45
1.95	22
2.5	0
3.05	-22
3.625	-45
4	-60
4.25	-70
4.75	-90

deg/V -40.0
V/deg -0.025

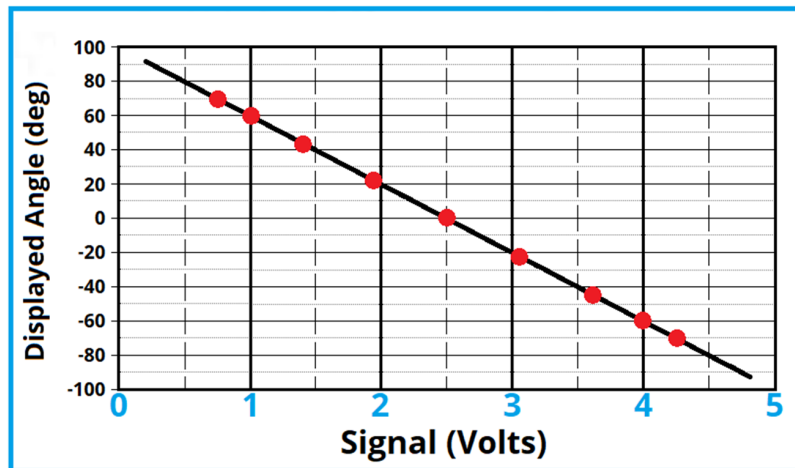

*From the graph, we can determine that:
Angle = (-40) x (signal voltage) + 100*

Step 15 continued

- d. **WHILE MANUALLY PRECESSING** enclosure, **MEASURE** voltage between pins **2** and **3** with multimeter in DC Volts mode **AND** back-probe attachment.
 - e. **COMPARE** voltages read at given angles, in table on previous page, to graph.
 - f. **IF** voltages do not match graph at given angles, **THEN REPLACE** angle sensor.
16. **IF** angle sensor does not calibrate after checking magnet, **THEN REPLACE** angle sensor.
- a. After replacement of sensor, **CYCLE** low current DC power to Seakeeper.
 - b. **REPEAT** angle sensor calibration per [SWI-108/108A](#).
 - c. **CHECK** alarm clear.
17. **ENSURE** GCM 70-pin connector is connected to GCM.
18. **UNPLUG** angle sensor from harness.
19. With multimeter in DC Volts mode, **MEASURE** voltage between pin **1** and **3** on wire harness angle sensor connector for 5.0VDC.
- a. **IF** 4.8 to 5.2VDC seen, **THEN PROCEED** to [Step 24](#).
20. **REMOVE** low current DC power from Seakeeper.
21. **UNPLUG** GCM 70-pin connector.



*Angle sensor
harness
connector with
back probes
installed*

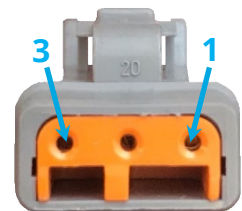

22. With multimeter in Resistance mode, **MEASURE** resistance from angle sensor harness connector to GCM 70-pin connector as follows:

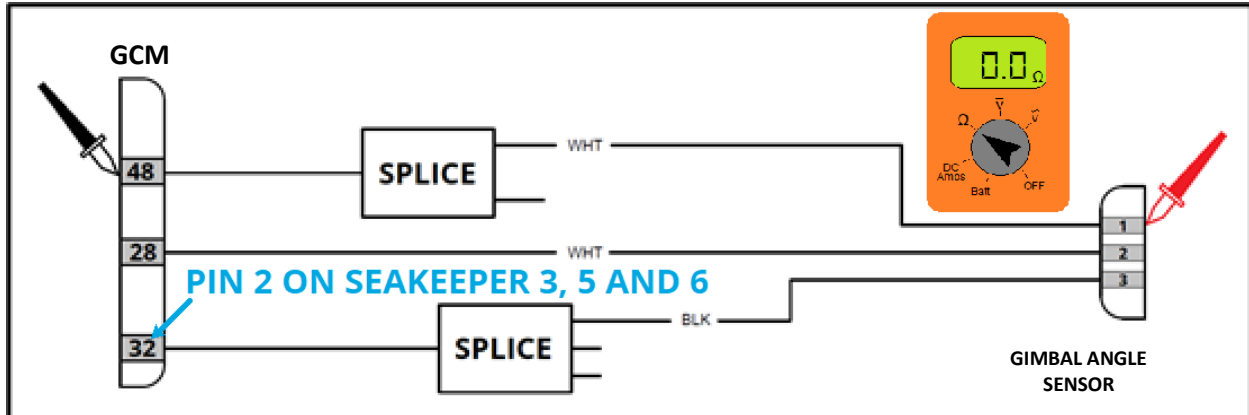

- a. **CONFIRM** resistance below 0.3Ω exists between pin **1** of sensor connector and GCM pin **48**.
- b. **CONFIRM** resistance below 0.3Ω exists between pin **2** of sensor connector and GCM pin **28**.
- c. **CONFIRM** resistance below 0.3Ω exists between pin **3** of sensor connector and GCM pin **2** on Seakeeper 3 – 6/5 (pin **32** on Seakeeper 2, 9/7HD or above).
- d. **IF** any resistance test of Steps 22.a through 22.c showed resistance higher than 0.3 ohms,
THEN:

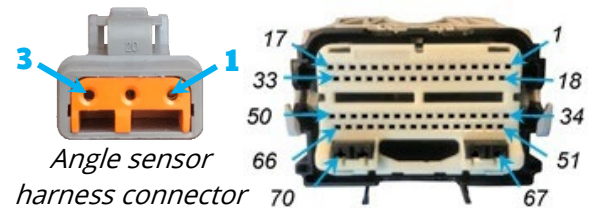

Angle Sensor GCM Pinout	
Pin 1:	GCM Pin 48 +5VDC supply
Pin 2:	GCM Pin 28 signal voltage
Pin 3:	GCM Pin 2 (Seakeeper 3, 5 (all) & 6) GCM Pin 32 (Seakeeper 2, 9/7HD & up)

- i. **VERIFY** wires of GCM and angle sensor connectors are secure and NOT loose.
 - 1. **REPAIR** pins that have loose crimps.
- ii. **IF** wires of connectors are satisfactory,
THEN REPLACE wire harness.

Step 22 continued

- e. **MEASURE** resistance between each lead of angle sensor harness connector for low resistance (short) as follows:
- VERIFY** greater than 1000Ω between pin **1** and pin **2**.
 - VERIFY** greater than 1000Ω between pin **1** and pin **3**.
 - VERIFY** greater than 1000Ω between pin **2** and pin **3**.

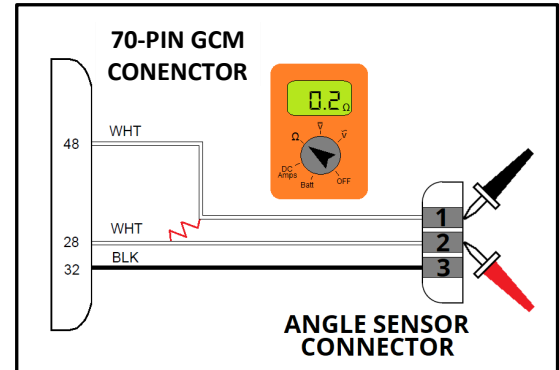

- f. **IF** any test in Step 22.e did **not** show resistance greater than 1000Ω (short), **THEN REPLACE** wire harness.

23. **IF** 4.8 to 5.2VDC is not seen between pins **1** and **3** in Step 19, **THEN REPLACE** GCM.

24. **IF** above steps have failed to identify cause of alarm(s), **THEN PERFORM** following:

- PERFORM** thorough brake service per [SWI-103 - Brake Service](#) instructions to remove all air from brake system.
- INSPECT** all brake cylinder rod ends for potential backing-out of threads.
- IF** rod end clevis threads are visible, **THEN PERFORM** following:
 - REMOVE** rod end from clevis.
 - CLEAN** threads with wire brush.
 - APPLY** red thread locker on threads.
 - INSTALL** rod end into clevis.

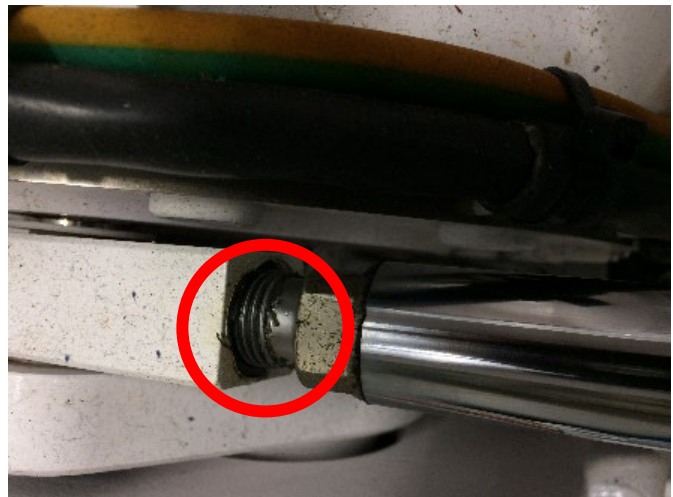

Step 24 continued

- d. **IF** Seakeeper 5 or 6,
THEN VERIFY bump stop pads are not worn/missing.
- **IF** bump stop pad(s) found worn/missing,
THEN REPLACE both pads.



- e. **PERFORM** sea trial to verify no alarms.
25. **IF** alarm persists,
THEN:
- RECORD** all readings (gimbal angles, resistances, voltages) taken during troubleshooting and photo of information screen.
 - SUBMIT** readings to Seakeeper Product Support Team at support@seakeeper.com.

******* END *******

CODE 32

To troubleshoot and repair the "Vertical Acceleration High" alarm (Code 32).

BACKGROUND

Vertical acceleration is hard on the internal components of the Seakeeper enclosure. This fault is displayed when the Inertia Measurement Unit (IMU) detects vertical motion above +3g or below -1g to secure the Seakeeper and alert the operator.

See the photo below for IMU identification.



*1st Generation IMU (IMU1)
It will appear on info screen as
"IMU: 1.00"*



*2nd Generation IMU (IMU2)
It will appear on info screen as
"IMU: 2.X"*

The vertical acceleration is never anticipated to be as high as the level at which the code alarms; proper installation location in the hull should preclude a high vertical acceleration event, even in smaller craft. In service cases, the alarm is usually due to water intrusion, loose mounting bolts, loose electrical panels, or loose mounting of the IMU itself. In addition, anything that might create abnormal 'vertical' motion or vibration induced into or on the IMU may be at fault. For example, it may be erroneously caused by severe sea conditions or running the vessel fixed directly into the seas. Finally, an internal fault in the IMU is also possible. In most service cases, the IMU is replaced. When replacing a first generation IMU, contact the Seakeeper Product Support Team for instructions in updating the GCM and display as necessary.

REFERENCES

Applicable Seakeeper Service Drawings on Dealer Access

Applicable [Seakeeper Installation Manual](#), Mechanical Installation Section

PRECAUTIONS

See [PRECAUTIONS](#) section of Introduction.

PROCEDURE

1. **DISCONNECT** wire harness connector at IMU.

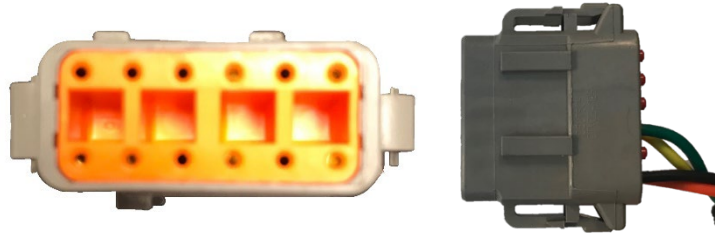

2. **INSPECT** IMU connector for loose pins or crimps.

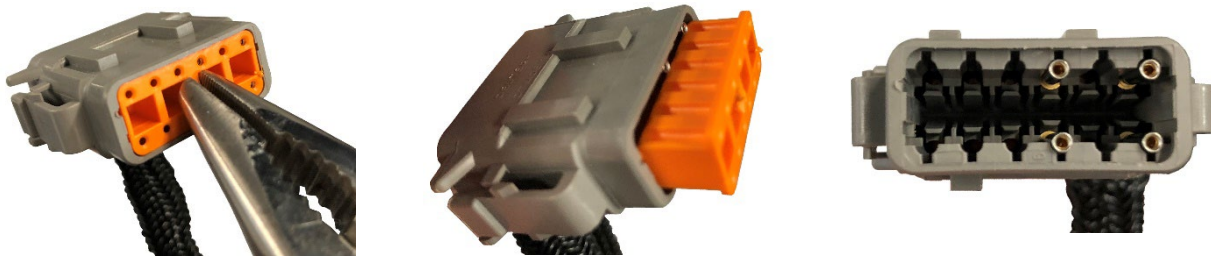

3. **IF** any loose wires or crimps found, **THEN REPAIR** IMU connector.
4. **IF** IMU found loose, **THEN FASTEN** IMU securely.



This damaged IMU pin prevented proper seating of harness connector.

This damaged IMU housing allowed water intrusion.



5. **IF** water intrusion found, **THEN INSPECT** other connectors (GCM 70-pin connector and MDB harness connector) of Seakeeper for water.
6. **IF** water intrusion found, **THEN REPLACE** wire harness.

7. **ENSURE** torque specifications are met on Seakeeper mounting bolts **AND** Cylinder Braces (per Torque Spec. Chart).

MODEL	MOUNTING BOLT TORQUE SPEC (ft-lbs/Nm)	CYLINDER BRACE TORQUE SPEC (ft-lbs/Nm)
Seakeeper 2 (ALL) Seakeeper 3 (3-0001 – 3-3835)	135 / 183	60 / 82
Seakeeper 3 (3-3836 and after)	155 / 210	
Seakeeper 3DC/5 (EM) (ALL) Seakeeper 5/6 (5/6-0001 – 5/6-5364)	65 / 88	50 / 68
Seakeeper 5/6 (5/6-5365 and later)	95 / 129	
Seakeeper 9/7HD, 16/12HD & Seakeeper 18	100 / 136	80 / 109
Seakeeper 26/20HD	100 / 136	75 / 102
Seakeeper 35/30HD/40	100 / 136	100 / 136

8. **CYCLE** low current DC power to Seakeeper.
9. **PERFORM** sea trial to ensure alarm does not return.

NOTE:

- Manipulate harness in manner to recreate slight movement during operation in event an open is not seen when cable is stationary.
- Disconnecting IMU, power relay, and GCM will produce alarms at display/MFD app.

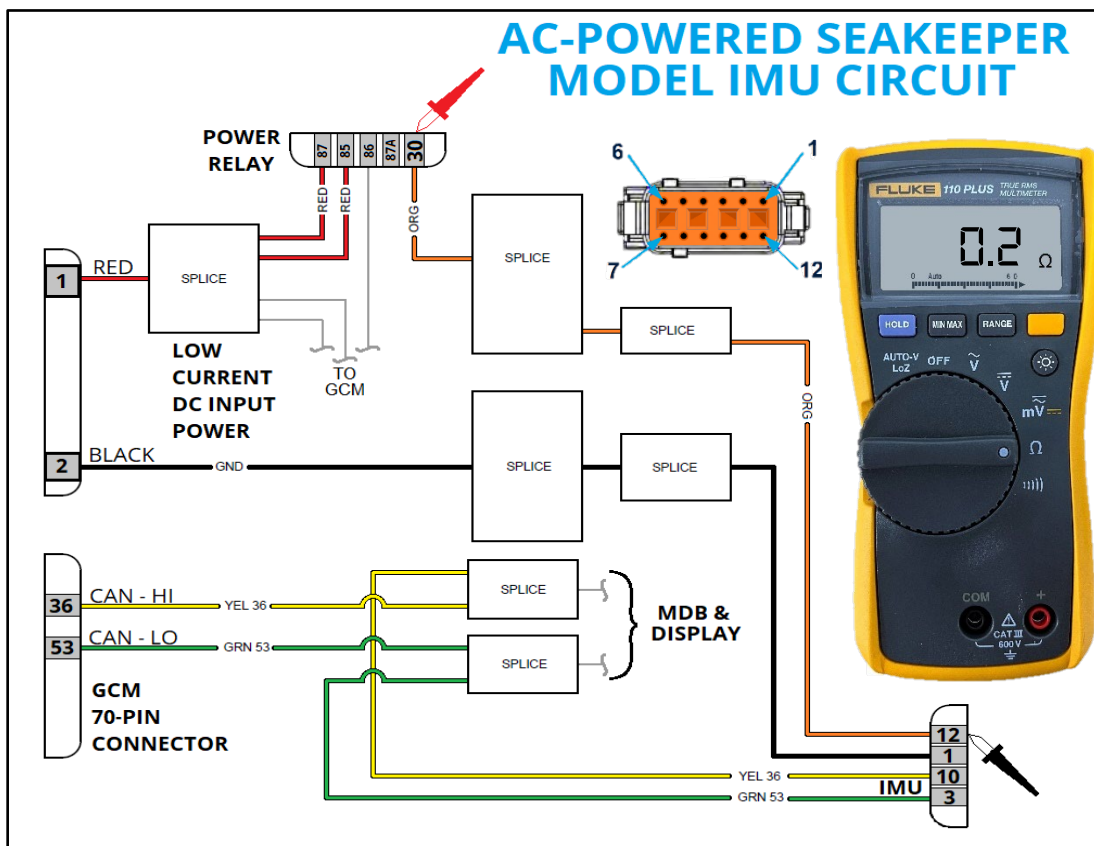
10. **CHECK** resistances of wire harness as follows:

- DISCONNECT** IMU, power relay (for AC-powered models), and GCM from wire harness.
- TEST AND RECORD** AC-powered Seakeeper readings as follows:
 - TEST** resistance below 0.3Ω from IMU pin **12** to power relay pin **30**.
 - TEST** resistance below 0.3Ω from IMU pin **1** to Low Current DC input connector pin **2**.
 - TEST** resistance below 0.3Ω from IMU pin **3** to GCM 70-pin connector pin **53**.
 - TEST** resistance below 0.3Ω from IMU pin **10** to GCM 70-pin connector pin **36**.

Step 10.b continued

- v. **IF** Seakeeper 26/20HD, 35/30HD, or 40,
THEN CONFIRM resistance below 0.3Ω from IMU pin **8** to GCM connector pin **21**.
- vi. **IF** Seakeeper 26/20HD, 35/30HD, or 40,
THEN CONFIRM resistance below 0.3Ω from IMU pin **7** to proportional valve pin **D**.
- vii. **IF** any resistance test was UNSATISFACTORY,
THEN:
 - 1. **VERIFY** wires and crimps of GCM and Proportional Valve (Seakeeper 26/20HD, 35/30HD, or 40 only) connectors are secure.



- 2. **IF** wires and crimps secure,
THEN REPAIR/REPLACE wire harness.

Step 10 continued

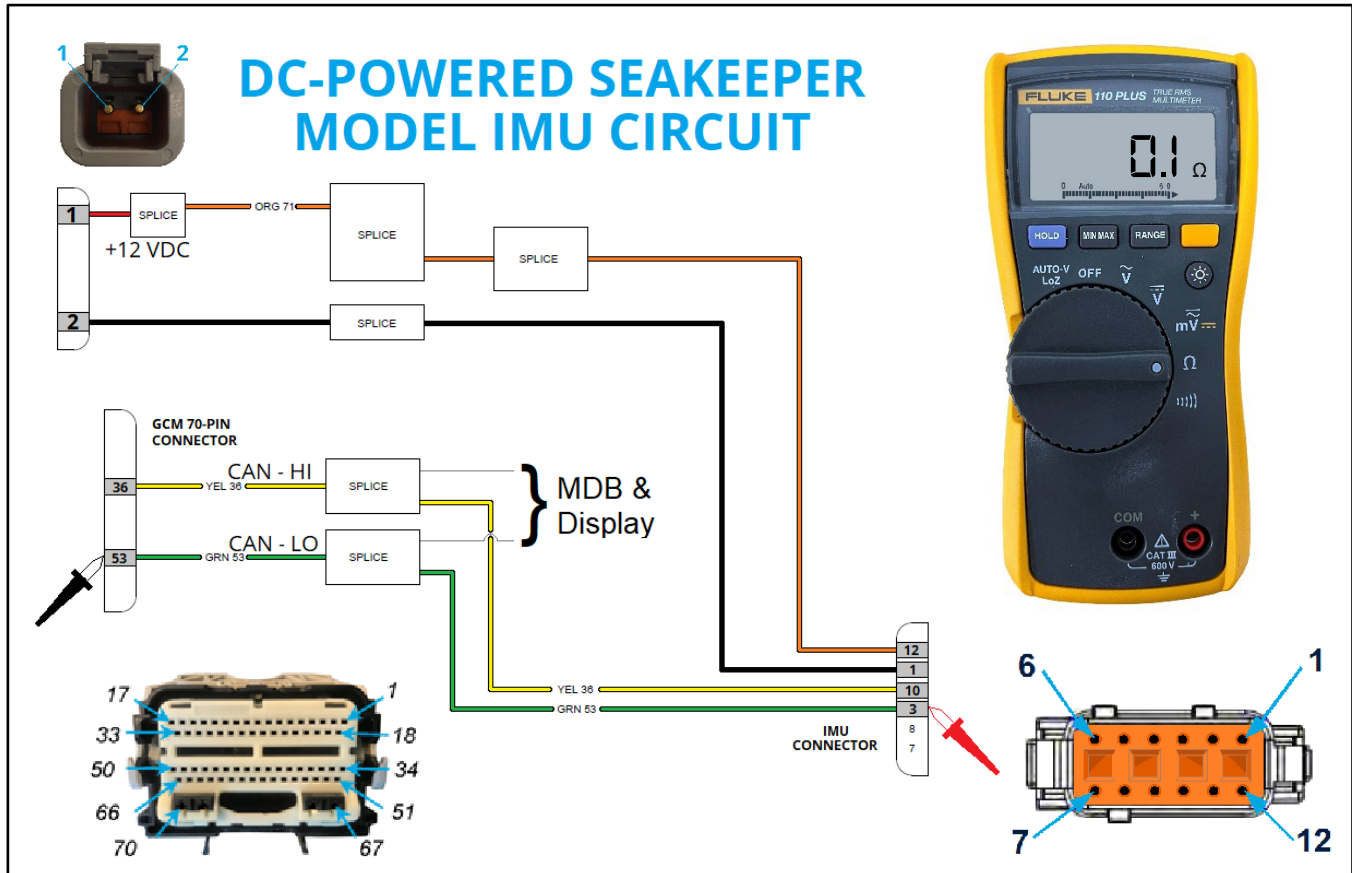
c. **TEST AND RECORD** DC-powered Seakeeper readings as follows:

- i. **TEST** resistance below 0.3 Ω from IMU pin **12** to Low Current DC Input pin **1**.
- ii. **TEST** resistance below 0.3 Ω from IMU pin **1** to Low Current DC Input pin **2**.
- iii. **TEST** resistance below 0.3 Ω from IMU pin **10** to GCM pin **36**.
- iv. **TEST** resistance below 0.3 Ω from IMU pin **3** to GCM pin **53**.
- v. **IF** any resistance test was UNSATISFACTORY, **THEN:**
 1. **CONFIRM** wires and crimps of associated connectors secure.
 2. **REPAIR/REPLACE** wire harness.

PRODUCT SEAKEEPER SERIES MODELS

Code 32

11. **IF** alarm persists **AND** IMU was not replaced previously,
THEN REPLACE IMU.
- a. **IF** replacing revision 1 IMU,
THEN CONTACT Seakeeper Product Support Team
at support@seakeeper.com for instructions.

Revision 1 IMU

12. **IF** alarm does not clear,
THEN:

NOTE:

GCM software 11.140 or later requires the Seakeeper Service Tool be installed before showing Seakeeper acceleration on Information screen.

- a. **RECORD** all resistances taken during troubleshooting and photo of information screen.
- i. **IF** GCM software 11.140 or later,
THEN ATTACH Seakeeper Service Tool app to Seakeeper to obtain all acceleration data on Information screen.
- b. **SUBMIT** all data to Seakeeper Product Support Team at support@seakeeper.com.

******* END *******

CODE 116/117/118

To troubleshoot and repair the:

- "VACUUM LEAK" alarm (Code 116)
- "VACUUM SENSOR FAULT-HIGH" alarm (Code 117)
- "VACUUM SENSOR FAULT LOW" alarm (Code 118)

BACKGROUND

These codes are unique to Seakeeper 35/30HD models. They are supplemental to code 128, Vacuum Pressure warning (greater than or equal to 85 Torr); these three codes will produce a coast signal to the flywheel motor to secure the Seakeeper when activated.

Code 116 will be displayed upon detecting an enclosure pressure of about 380 Torr by the vacuum sensor. Resetting is possible once enclosure pressure has been reduced below 100 Torr. Code 116 will not activate if either Code 117 or 118 is in alarm.

A voltage signal from the vacuum sensor activates codes 117 and 118. The sensors operate on 5VDC supplied by the Gyro Control Module (GCM). The signal voltage from the sensor to the GCM is between 0.5VDC and 4.5VDC, depending on enclosure pressure. The applicable code is activated when the signal goes below or above this range. These codes indicate a failure in the vacuum sensor, wiring, or a failure in the GCM (either software or hardware).

An actual vacuum leak will require a vacuum service to correct it. In addition, codes 117 & 118 may require a vacuum service if the vacuum sensor is to be replaced. Most troubleshooting in this guide will pursue electrical faults that may cause these alarms. However, if the issue is not electrical, contacting the Seakeeper Product Support Team will be necessary for vacuum service (support@seakeeper.com).

REFERENCES

[SWI-116 – Seakeeper Vacuum Service](#)

PRECAUTIONS

See [PRECAUTIONS](#) section of Introduction.

PROCEDURE

1. **IF** Code 163 present in recent alarm history,
THEN:
 - a. **THOROUGHLY INSPECT** enclosure sphere for evidence of leakage.
 - b. **PERFORM** vacuum service per [SWI-116 - Seakeeper Vacuum Service](#).
2. **ENSURE** following electrical connections on Seakeeper are securely fastened:
 - a. GCM 70-pin connector at GCM
 - b. 3-pin connector of Vacuum Sensor
 - c. Guide band connector of harness at base of right-side guide band

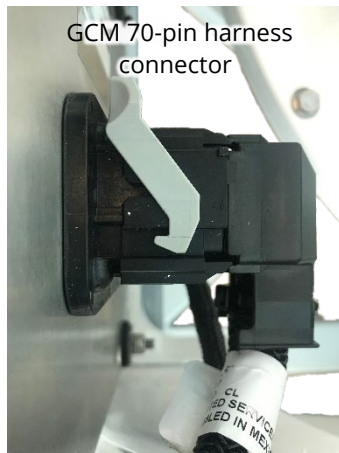

3. **VISUALLY INSPECT** enclosure sphere thoroughly for evidence of leakage.
4. **DISCONNECT** harness connector from vacuum sensor.
5. **INSPECT** pins and sockets for corrosion.
6. **IF** corrosion found,
THEN CAREFULLY CLEAN pins and sockets of connectors.
7. **CYCLE** DC power to Seakeeper by momentarily (5 seconds or longer) opening and then closing supply breaker.

8. **INSPECT** wire harness for any damage.

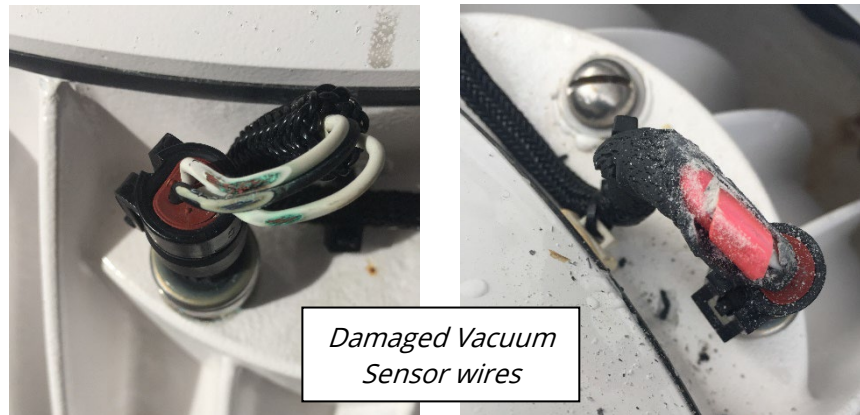

9. **IF** any wire harness damage found, **THEN REPLACE** wire harness.

10. **IF** display or MFD app reads 0 Torr, **THEN PERFORM** following:

- a. **RECORD** results of each test in this step.
- b. **DISCONNECT** vacuum sensor from wire harness.
- c. **DISCONNECT** GCM 70-pin connector.
- d. **DISCONNECT** bearing temperature thermistors from wire harness.
- e. **TEST** for short between pin **1 (B)** and pin **3 (A)** of harness connector.
- f. **TEST** for short between pin **1 (B)** and pin **2 (C)** of harness connector.
- g. **TEST** for short between pin **2 (C)** and pin **3 (A)** of harness connector.
- h. **CONNECT** GCM 70-pin connector.
- i. **ENSURE** DC power is energized.
- j. **TEST** for 4.9 to 5.1VDC between pin **1 (B)** and pin **3 (A)** of harness connector.

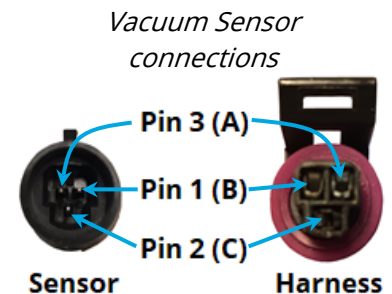

11. **IF** any test in steps 10.e through 10.g showed resistance less than "OL" (infinity), **THEN PERFORM** following:
- a. **DISCONNECT** guide band connector of wire harness (at base of right-side guide band).

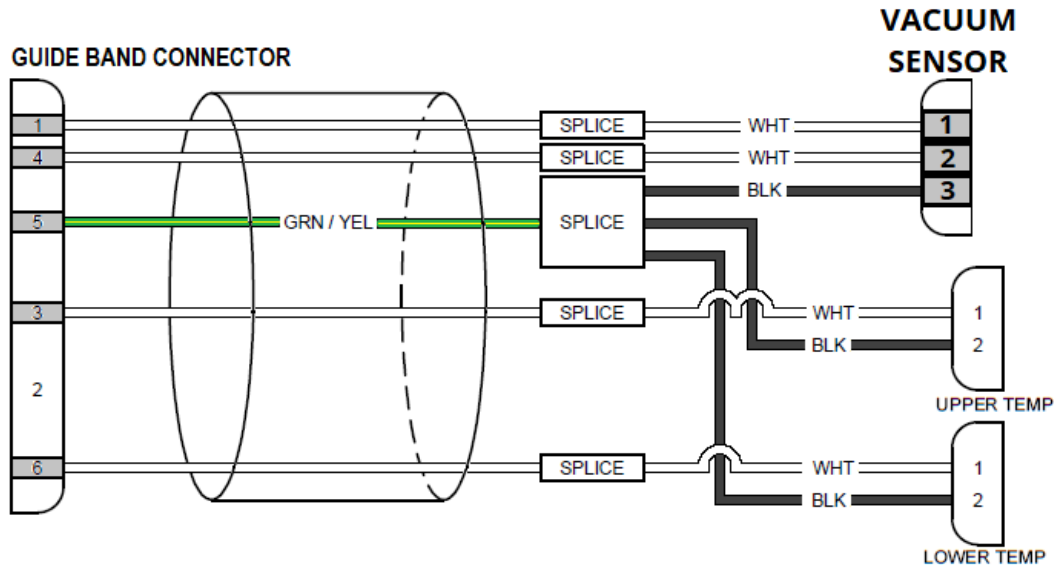

- b. **TEST** for short between pin **1 (B)** and pin **3 (A)** of harness connector.
- c. **TEST** for short between pin **1 (B)** and pin **2 (C)** of harness connector.
- d. **TEST** for short between pin **2 (C)** and pin **3 (A)** of harness connector.
- e. **IF** short found in Step 11.b through 11.d, **THEN REPLACE** guide band harness.
- f. **IF** no short found in 11.b through 11.d, **THEN REPLACE** wire harness of foundation.

12. **IF** 4.9 to 5.1VDC was not seen in step 10.i,
THEN PERFORM following test on harness:

- a. **DISCONNECT** GCM 70-pin connector.
- b. **TEST** resistance below 0.3Ω between pin **1 (B)** and GCM pin **48**.
- c. **TEST** resistance below 0.3Ω between pin **2 (C)** and GCM pin **24**.
- d. **TEST** resistance below 0.3Ω between pin **3 (A)** and GCM pin **2**.
- e. **IF** any test in steps 12.b through 12.d show high resistance,
THEN PROCEED to next step.

Vacuum Sensor Pin out to GCM:

Pin 1(B) = pin 48 (5v Supply)
 Pin 2(C) = pin 24 (Signal Voltage)
 Pin 3(A) = pin 2 (GND)

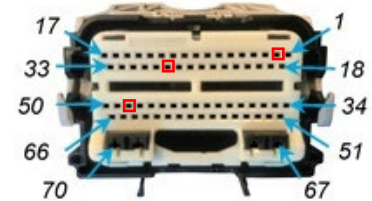

Vacuum Sensor connections

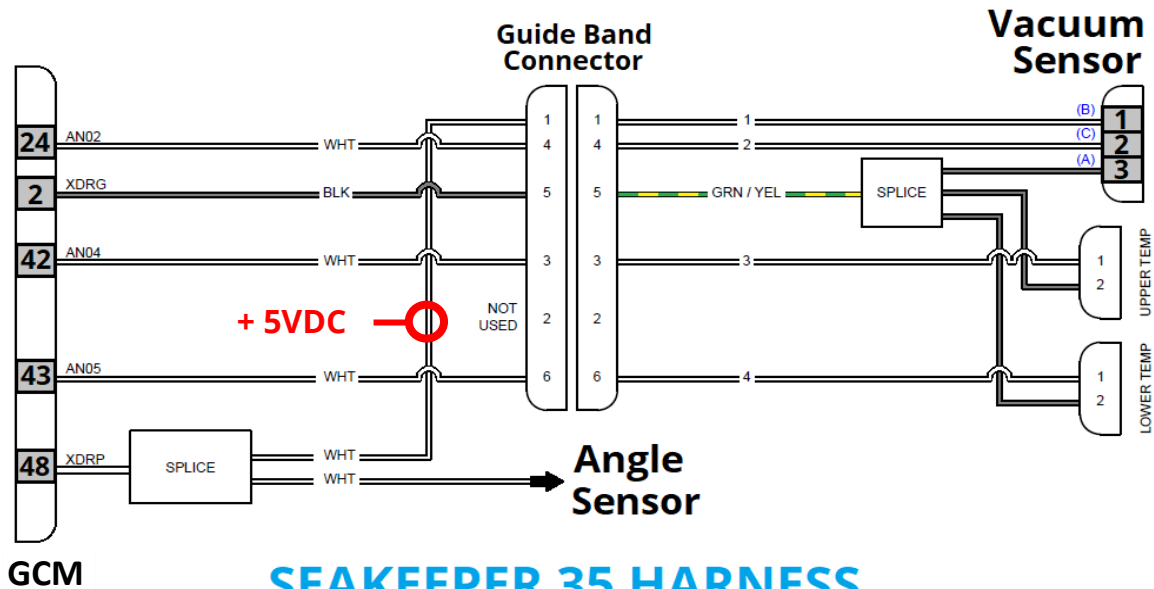
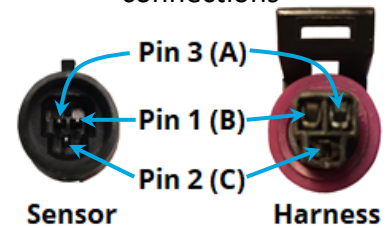

13. **IF** open loop found in steps 12.b through 12.d,
THEN PERFORM following:

a. **DISCONNECT** guide band connector of wire harness (at base of right-side guide band).

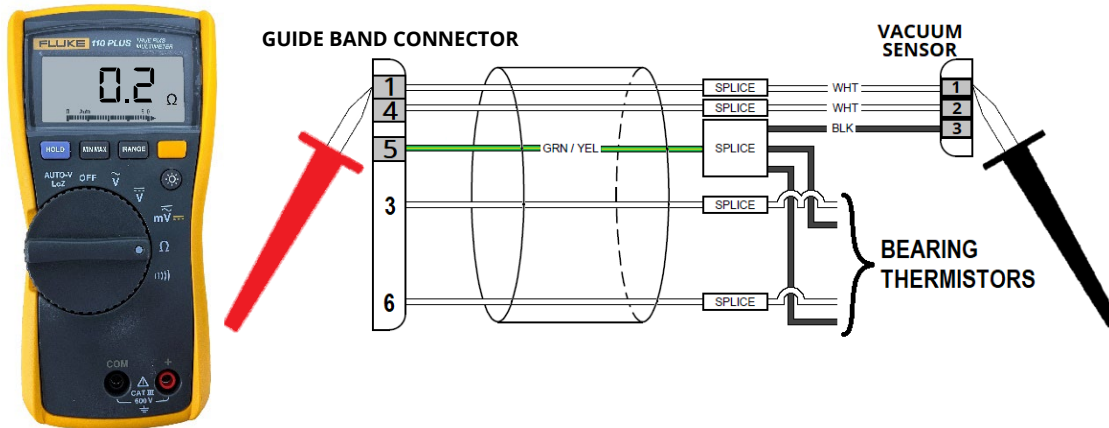

b. **TEST** resistance below 0.3Ω between sensor connector pin **1 (B)** and guide band connector pin **1**.

c. **TEST** resistance below 0.3Ω between sensor connector pin **2 (C)** and guide band connector pin **4**.

d. **TEST** resistance below 0.3Ω between sensor connector pin **3 (A)** and guide band connector pin **5**.

e. **IF** high resistance or open loop found in Step 13.b through 13.d,
THEN:

i. **INSPECT** for loose wires and crimps in connectors.

ii. **REPAIR OR REPLACE** guide band harness.

14. **TEST** vacuum sensor as follows:

- a. **RECONNECT** all electrical connections in GCM, vacuum sensor, and bearing temperature sensors.
- b. **CYCLE** DC power to Seakeeper by momentarily (5 seconds or longer) opening and then closing supply breaker.
- c. Using a set of back-probes (example shown below) and a multimeter in "DC Voltage" mode, **TEST** vacuum sensor at pins **3(A)** & **2(C)**.

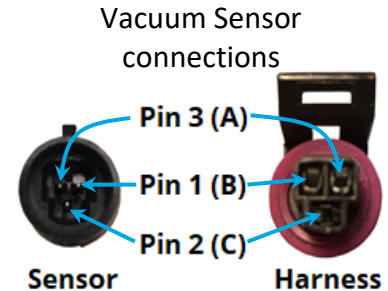

NOTE: The voltage read should be along the red line of the graph shown for a known enclosure pressure. Assuming vacuum is fine, the voltage read should be between 0.5VDC (0 Torr) and 1.3VDC (150 Torr).

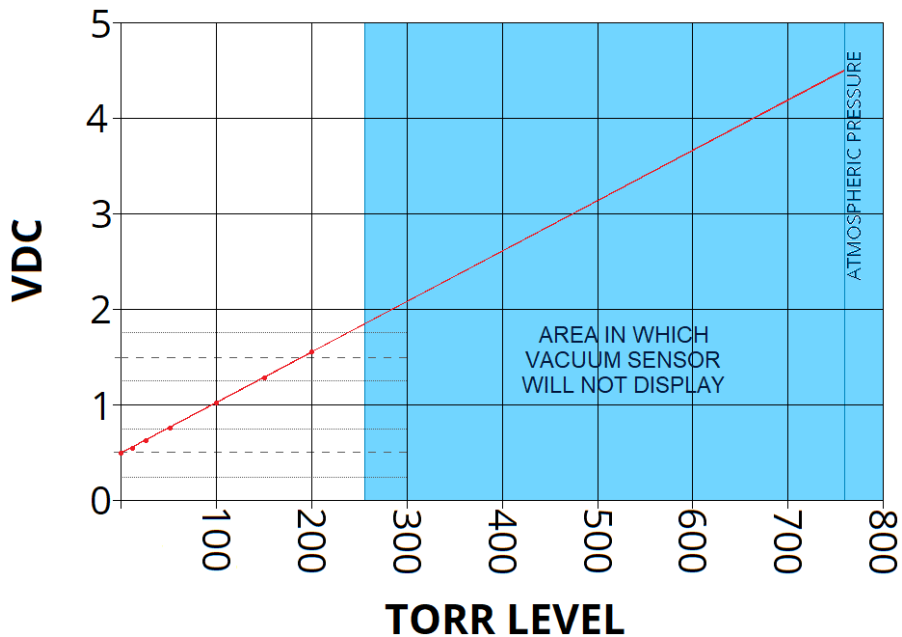

- d. **IF** Code 163 is NOT present in alarm history (Slow Spool Up), **THEN CONSIDER** vacuum sensor in need of replacement at voltages greater than 2.0VDC or less than 0.5VDC.
- e. **IF** vacuum sensor needs replacement **AND** a vacuum service kit is unavailable, **THEN CONTACT** Seakeeper Product Support Team at support@seakeeper.com.

15. **IF** all electrical tests were SATISFACTORY,
THEN PERFORM following check of GCM connector:
- a. **REMOVE** white face panel from 70-pin GCM connector.
 - b. **CHECK** that each socket is fully seated (not pushed in).

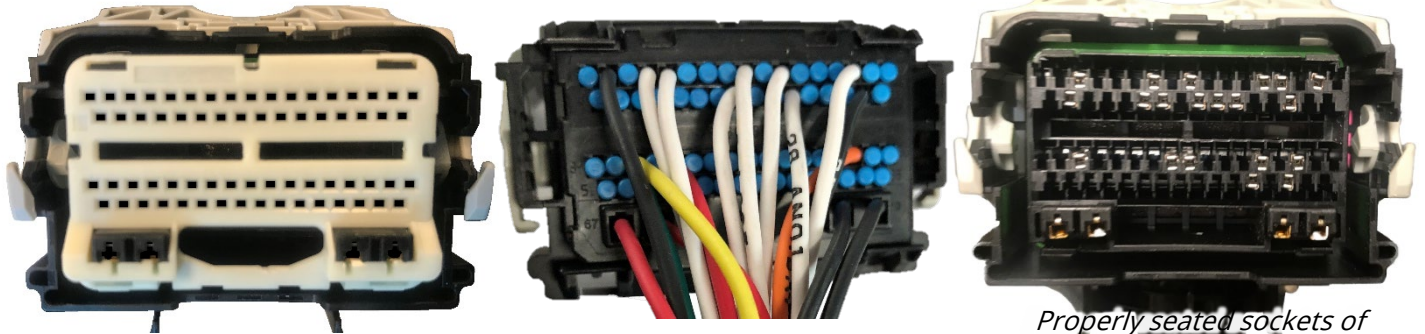

*Properly seated sockets of
a GCM 70-pin connector*

- c. **IF** any socket had to be reseated,
THEN CYCLE DC power to Seakeeper and check alarm clear.
16. **IF** checks of 70-pin connector are SATISFACTORY,
THEN:
- a. **RECORD** all data taken (voltages & resistances) and a photo of information screen.
 - b. **SUBMIT** data and photos to Seakeeper Product Support Team at support@seakeeper.com for review.

******* END *******

CODE 128/137/146

To troubleshoot the following warning codes:

"VACUUM PRESSURE" warning (Code 128)

"VACUUM SENSOR FAULT" warning (Code 137 or 146).

BACKGROUND

The vacuum pressure warning may be displayed when the enclosure pressure reaches 60 to 85 Torr. Since it is only a warning, no automatic actions will occur. Operation may continue. The warning only serves as an early warning to the operator of a potential vacuum leak. The warning would reset once it senses an enclosure pressure of less than 55 Torr. NOTE: Some models are not equipped with a vacuum sensor and would not produce either code.

MODEL VACUUM SENSOR STATUS		
MODEL	SERIAL RANGE	VACUUM SENSOR?
Seakeeper 3	3-0001 to -203-1304	YES
	3-203-1305 to current	NO
Seakeeper 6/5	6/5-0001 to -203-2254	YES
	6-203-2255 to current	NO
Seakeeper 9/7HD	9-0001 to -203-3009	YES
	9-203-3010 to current	NO
Seakeeper 18/16/12HD	18/16-194-0001 to -203-0117	YES
	18/16-203-0118 to current	NO
Seakeeper 26	26-0001 to -203-0374	YES
	26-203-0375 to current	NO
Seakeeper 35	ALL	YES
Seakeeper 40	ALL	NO

The two sensor fault warnings will appear on the display or MFD app if the vacuum sensor feedback voltage reaches 5VDC (Code 137) or the sensor feedback voltage is zero VDC (Code 146). Either of these faults would be an indication of a sensor fault only. Troubleshooting these electrical issues will be discussed in this guide.

If a Code 128, Vacuum Pressure Warning, is present in the alarm history with a Code 163, Slow Spool-Up alarm, the possibility of a vacuum leak is high. For an actual vacuum leak, dealers are encouraged to contact the Seakeeper Product Support Team for additional instructions.

REFERENCES

Applicable [Seakeeper Enclosure](#) drawing.

PRECAUTIONS

See [PRECAUTIONS](#) section of Introduction.

PROCEDURE

1. **CHECK** following electrical connections on Seakeeper are securely fastened:
 - a. GCM 70-pin connector
 - b. 3-pin connector of Vacuum Sensor
 - c. Guide band connector of harness at base of right-side guide band. **[N/A on DC models]**

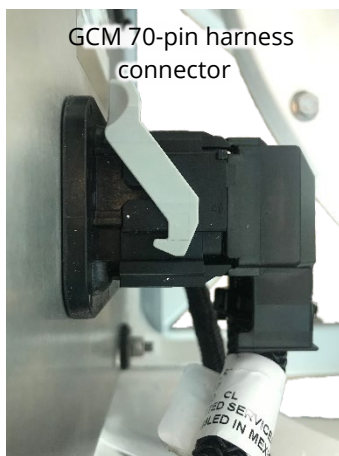

2. **DISCONNECT** harness connector from vacuum sensor.
 - a. **INSPECT** pins and sockets for corrosion, and loose wires or crimps.
3. **IF** issues found, **THEN CAREFULLY CLEAN OR REPAIR** pins and sockets of connectors.
4. **CYCLE** low side DC power to Seakeeper by momentarily (5 seconds or longer) opening and then closing supply breaker.

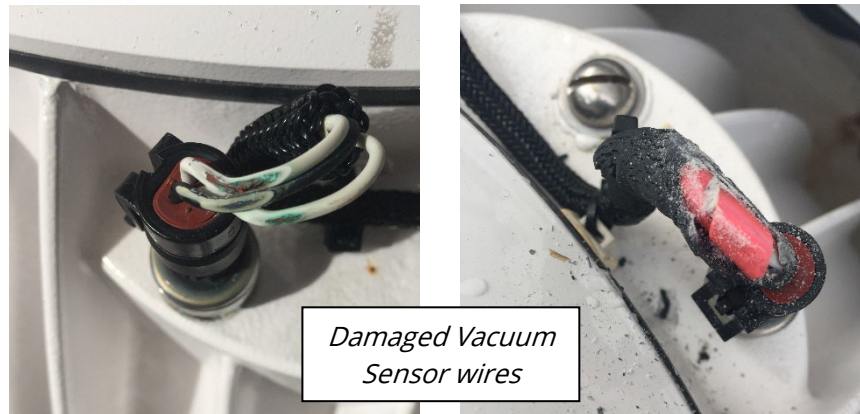
5. **CHECK** for wire harness damage:

- a. **VISUALLY INSPECT** wire harness between sensor and GCM.
 - b. **ACTIVATE** brake override.
 - c. **WHILE MANUALLY PRECESSING** enclosure, **MONITOR** vacuum.
 - d. **IF** any wire harness damage found or erratic vacuum reading when precessing, **THEN REPLACE** wire harness.
6. **IF** display or MFD app reads 0 Torr, **THEN PERFORM** following multimeter tests:

- a. **DISCONNECT** vacuum sensor from wire harness **AND** GCM 70-pin connector.
- b. **DISCONNECT** bearing temperature thermistors from wire harness.
- c. **TEST** for short between pin **1 (B)** and pin **3 (A)** of harness connector.
- d. **TEST** for short between pin **1 (B)** and pin **2 (C)** of harness connector.
- e. **TEST** for short between pin **2 (C)** and pin **3 (A)** of harness connector.
- f. **CONNECT** 70-pin connector **AND ENSURE** DC power is energized.
- g. **TEST** for 4.9 to 5.1VDC between pin **1 (B)** and pin **3 (A)** of harness connector.
- h. **RECORD** results of each check above for following action steps.

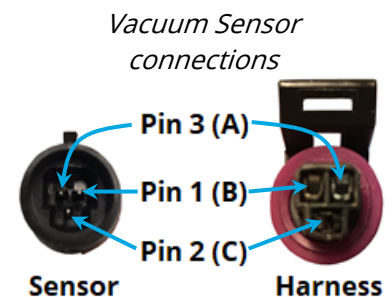

PRODUCT SEAKEEPER SERIES MODELS

Code 128/137/146

7. **IF** any test in steps 6.c through 6.e showed resistance less than open loop (OL), **THEN PERFORM** following:
- a. **IF** Seakeeper 3, **THEN REPLACE** wire harness.
 - b. **IF** AC-powered model, **THEN:**
 - i. **DISCONNECT** guide band connector of wire harness (at base of right-side guide band).

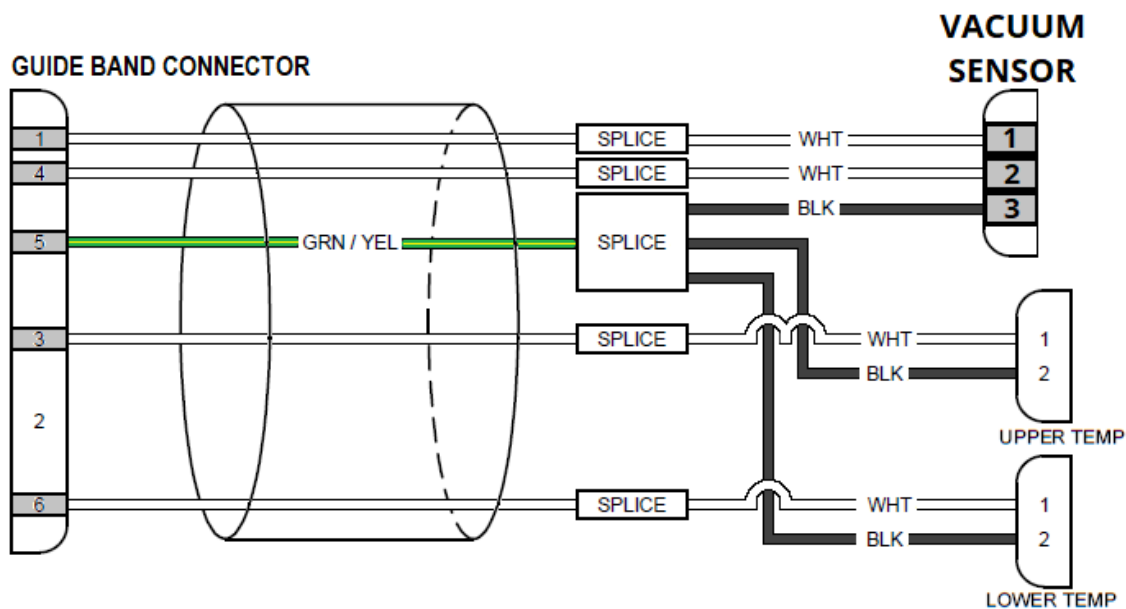

- ii. **TEST** for short between pin **1 (B)** and pin **3 (A)** of harness connector.
- iii. **TEST** for short between pin **1 (B)** and pin **2 (C)** of harness connector.
- iv. **TEST** for short between pin **2 (C)** and pin **3 (A)** of harness connector.
- v. **IF** short found in Step 7.b.ii through 7.b.iv, **THEN REPLACE** guide band harness.
- vi. **IF** no short found in 7.b.ii through 7.b.iv, **THEN REPLACE** wire harness of foundation.

8. **IF** 4.9 to 5.1VDC was not seen in step 6.g,
THEN PERFORM following test on harness:

- a. **REMOVE** 70-pin GCM connector.
- b. **TEST** resistance below 0.3Ω between pin **1 (B)** and GCM pin **48**.
- c. **TEST** resistance below 0.3Ω between pin **2 (C)** and GCM pin **24**.
- d. **TEST** resistance below 0.3Ω between pin **3 (A)** and GCM pin **2**.
- e. **IF** any test in steps 8.b through 8.d show high resistance,
THEN:
 - i. **INSPECT** for loose wires and crimps in connectors
- f. **IF** all resistance checks were SATISFACTORY,
THEN REPLACE GCM.

Vacuum Sensor Pin out to GCM:

Pin 1(B) = pin 48 (5v Supply)
Pin 2(C) = pin 24 (Signal Voltage)
Pin 3(A) = pin 2 (GND)

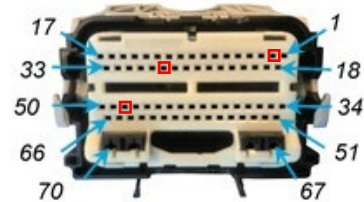

Vacuum Sensor connections

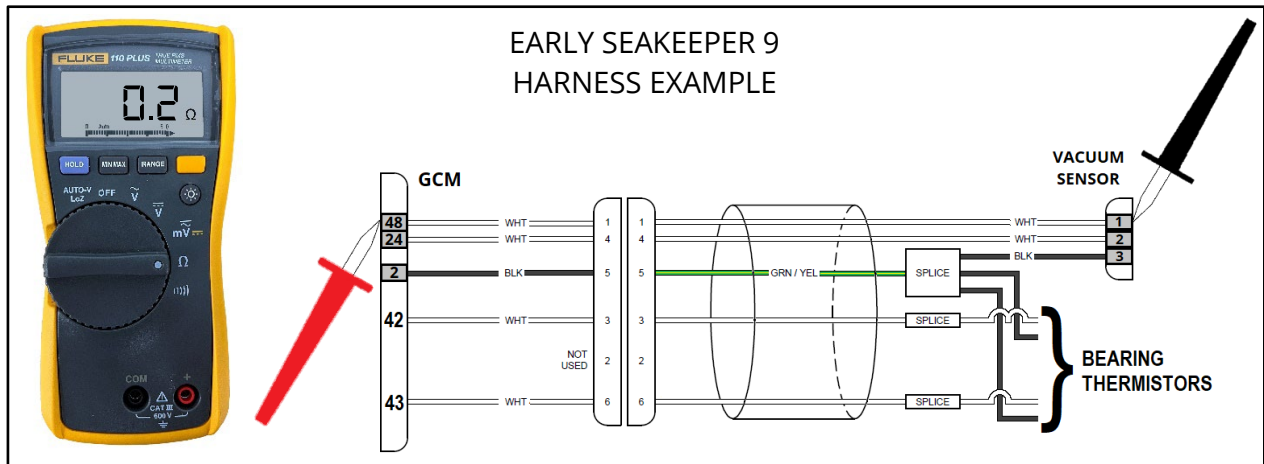
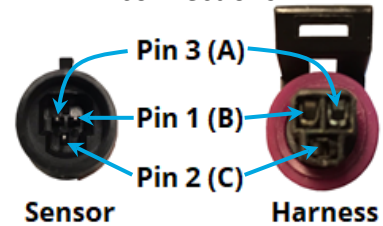

9. **IF** open loop found in steps 8.b through 8.d,
THEN PERFORM following:

a. **IF** Seakeeper 3,
THEN REPLACE wire harness.

b. **IF** AC-powered model,
THEN:

i. **DISCONNECT** guide band connector of wire harness (at base of right-side guide band).

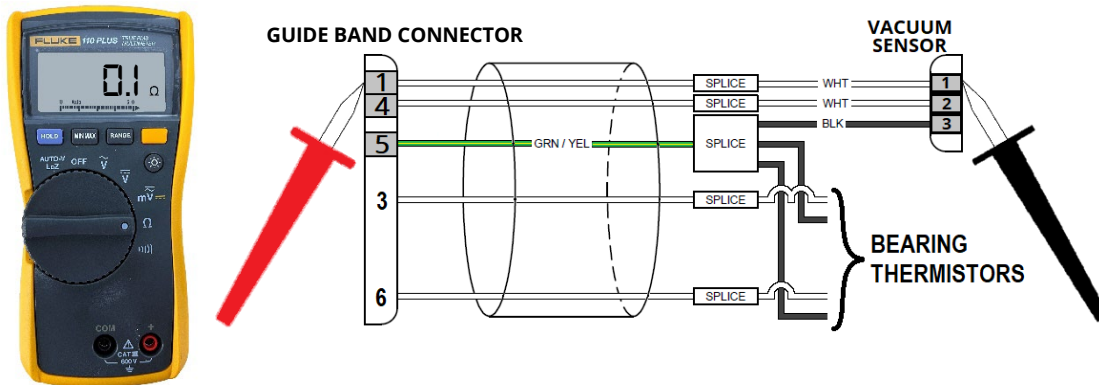

ii. **TEST** resistance below 0.3Ω between sensor connector pin **1 (B)** and guide band connector pin **1**.

iii. **TEST** resistance below 0.3Ω between sensor connector pin **2 (C)** and guide band connector pin **4**.

iv. **TEST** resistance below 0.3Ω between sensor connector pin **3 (A)** and guide band connector pin **5**.

v. **IF** high resistance found in Step 9.b.ii through 9.b.iv,
THEN REPLACE guide band harness.

vi. **IF** resistance checks SATISFACTORY,
THEN REPLACE wire harness of foundation.

PRODUCT SEAKEEPER SERIES MODELS

Code 128/137/146

10. **TEST** vacuum sensor as follows:

- a. **RECONNECT** all electrical connections in GCM, vacuum sensor, and bearing temperature sensors.
- b. **CYCLE** low side DC power to Seakeeper by momentarily (5 seconds or longer) opening and then closing supply breaker.
- c. Using a set of back-probes and a multimeter in "DC Voltage" mode, **TEST** vacuum sensor at pins **3(A)** & **2(C)**.

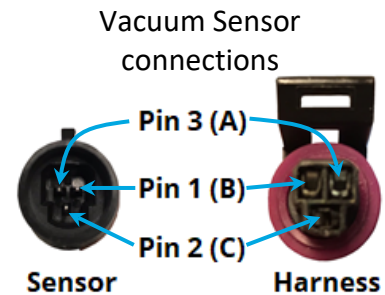

NOTE: The voltage read should be along the red line of the graph shown for a known enclosure pressure. Assuming vacuum is fine, the voltage read should be between 0.5VDC (0 Torr) and 1.3VDC (150 Torr).

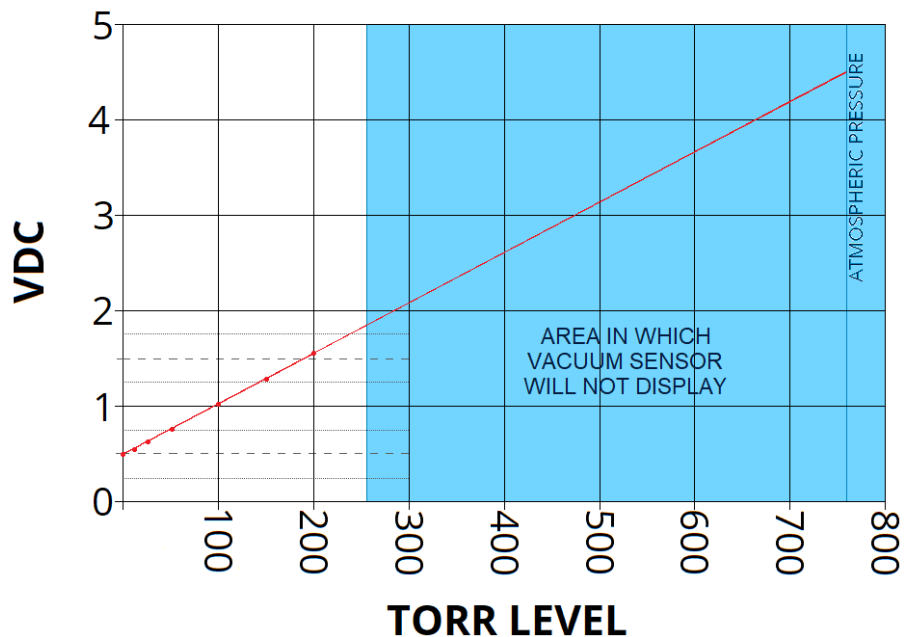

- d. **IF** Code 163 (Slow Spool Up) is NOT present in alarm history, **THEN CONSIDER** vacuum sensor in need of replacement at voltages greater than 2.0VDC or less than 0.5VDC
- e. **IF** vacuum sensor needs replacement **AND** a vacuum service kit is unavailable, **THEN CONTACT** Seakeeper Product Support Team at support@seakeeper.com.

SEAKEEPER TROUBLESHOOTING GUIDE - 106



PRODUCT SEAKEEPER SERIES MODELS

Code 128/137/146

11. **IF** alarm persists after cycling DC power,
THEN SUBMIT data referenced below to Seakeeper Product Support Team at support@seakeeper.com.
- a. **INCLUDE** in data submittal:
 - i. Vessel information
 - ii. Alarm history and hours
 - iii. Electrical test readings
 - iv. Videos/pictures of testing and of Seakeeper

******* END *******

NOISE & VIBRATION 🏠

This guide is to diagnose the cause of noise, vibrations, or clunking in a Seakeeper. There is often no associated alarm code.

BACKGROUND

Noise or vibration can result from different issues:

- loose mounting screws
- brake cylinder misalignment
- poor deck mounting installation on smaller craft
- isolation bushing deterioration on larger models
- GCM software issues
- faulted bearings
- electrical motor noise

Certain noises from the Seakeeper have been identified as acceptable during certain operations; these noises may be only a temporary inconvenience for occupants during the spool-up and spool-down of the flywheel.

This guide may not provide a complete repair because of the possibility of internal enclosure components causing noise and vibration. Instead, it will guide the technician in isolating noise from the enclosure and how to document the noise for engineering analysis.

Noises from the enclosure during spool-up or spool-down, such as cage rattle or electrical motor noise, are normal and expected. These noises may be emitted from the Seakeeper as it spools up or coasts down in various speed ranges. However, it's important to understand that at normal operating speed, these noises should dissipate and no longer be noticeable. Importantly, these cage rattle and electrical motor noise are not indicators of any imminent failure. They are simply normal occurrences that have no impact on the regular operation or performance of the Seakeeper, ensuring its reliability.

REFERENCES

[SWI-103 - Seakeeper Brake Service](#)

[SWI-108 - Seakeeper Angle Sensor Calibration](#)

[SWI-109 - Seakeeper Brake Bushing Service](#)

[SWI-125 - Seakeeper Isolation Bushing Service](#)

[Seakeeper Installation Drawings](#)

PRECAUTIONS

See [PRECAUTIONS](#) section of Introduction.

PROCEDURE**SECTION 1: Source Identification**

1. **OBTAIN AND DOCUMENT** as much information about symptoms from owner/operator or by observation:
 - a. **WHEN** does noise occur? During spool-up when unit is cold? After unlocking sphere? When rolling to starboard or port?
 - b. **WHAT** symptoms are present? High-pitched noise? Low-pitched noise through hull? Is it a clunking or slamming noise?
 - c. **WHERE** on Seakeeper does noise appear to originate?
2. **REVIEW** alarm history on display or MFD app. (Codes that correspond to noise may have been ignored if immediately reset.)
3. Based on interview or observation, **PROCEED** to appropriate section:
 - a. Vibrations in hull, **PROCEED** to [Section 2](#): Installation Issues, and, if Seakeeper 26, 35, or 40 [Section 5](#): Isolation Bushings.
 - b. Constant-pitched noises consistent with flywheel speed, **PROCEED** to [Section 3](#): Internal Enclosure Issues.
 - c. Definite slamming, banging, or clunking with precession, **PROCEED** to [Section 4](#): Cylinder Alignment (Seakeeper 5/6, 9, or 16/18 only), and [Section 6](#): Slamming/Clunking/Banging.
4. **IF** no benefit of interview with vessel personnel, **THEN CONTINUE** in this section.
5. **ENSURE** flywheel at zero RPM, **AND DEENERGIZE** AC or High current DC power to Seakeeper.
6. **ACTIVATE** brake override.
7. **PERFORM** following inspections:
 - a. **LOOK** for corrosion around brake pins or trunnions.
 - i. **IF** corrosion found, **THEN PERFORM** brake bushing replacement per [SWI-109](#) **AND REPLACE** brake hardware (pins, retaining rings, and spacers).

Section 1, Step 7 continued

- b. **INSPECT** mounting fasteners for corrosion.
 - i. **IF** mounting fastener corrosion found, **THEN PROCEED** to [Section 2: Installation Issues](#).
 - c. **FULLY PRECESS** enclosure manually while listening for noises or feeling for resistance.
 - i. **IF** enclosure does not move freely forward and aft while precessing, **THEN PROCEED** to [Section 4: Cylinder Alignment](#).
8. **ATTACH** brake kit to Seakeeper per [SWI-103](#) **AND PERFORM** following:
- a. **RECORD** as-found brake pressure.
 - b. **IF** brake pressure found low, **THEN CONFIRM** no leak exists at cylinder rods, hydraulic fittings or on manifold.
 - i. **IF** leak(s) found, **THEN CORRECT** per [Code 12/13/14 Troubleshooting Guide](#).
 - c. Despite as-found brake pressure, **BLEED** fluid from cylinders and monitor for indication of air in fluid.



Corroded mounting bolts found loose.

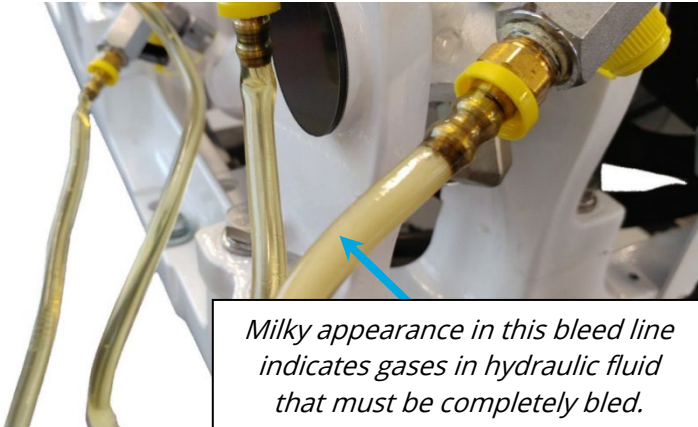

Milky appearance in this bleed line indicates gases in hydraulic fluid that must be completely bled.
 - d. **IF** gases found in fluid, **THEN COMPLETELY** bleed brake system per [SWI-103](#).
 - e. **PRESSURIZE** brake system per [SWI-103](#).
9. **DEACTIVATE** brake override.



PRODUCT SEAKEEPER SERIES MODELS

Noise & Vibration

10. **DOCUMENT** data from information screen with photo.

11. **START** Seakeeper:

a. **MONITOR** spool-up for noises and note RPMs at which any occur.

b. **MONITOR** bearing and drive temperatures during spool-up (if available).

c. **IF** noises heard from enclosure, **THEN PROCEED** to [Section 3: Enclosure Issues](#).

12. **PERFORM** sea trial.

13. From sea trial inspections, **PROCEED** to appropriate section listed in [Step 3](#).

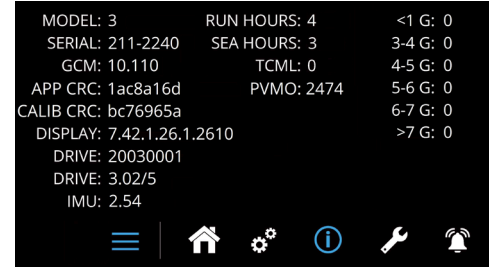
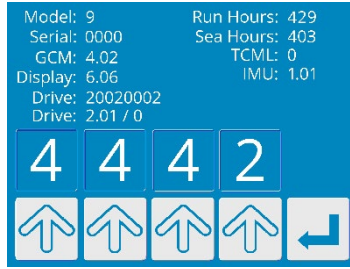

SECTION 2: Installation Issues**NOTE:**

- Seakeeper Standard Warranty does not cover installation of a Seakeeper on a vessel, or design of any installation, including foundation.
- Correcting issues may involve lifting/removal of Seakeeper to correct stringer issues (glass, backing plates, etc.).

1. **INSPECT** mounting screws as follows:
 - a. **CHECK** torque of mounting screws per [Torque Specifications](#) section.
 - b. **IF** one or more mounting screws are loose or significantly corroded, **THEN:**
 - i. **REMOVE** a minimum of two mounting screws.
 - ii. **INSPECT** threads for damage/stripping.
 1. **IF** threads damaged, **THEN INSPECT** fastener length for sufficient thread engagement. [**NOTE:** Thread engagement should be 1.5X fastener diameter for blind hole installations.]
 - iii. **IF** thru-bolt installation, **THEN ENSURE** nut is captured when torquing. [**NOTE:** Thru-bolt thread engagement should be two threads beyond nut]
 - c. With bright flashlight, **INSPECT** threads of mounting holes of removed screws.
 - d. With aluminum tapping plates, for bolt-in installations, **ENSURE** helicoil or solidwall threaded insert is used at each fastener.
 - e. **CHECK** bolt threads for proper thread lubricant. [For flat or split-lock washers blue thread locker should be used. For wedge lock washers, nickel-based anti-seize should be used]

Section 2, Step 1 continued

- f. **IF** threaded inserts or tapping plate threads are satisfactory, **THEN REPLACE** removed mounting fasteners with new fasteners matching installed length and specification (diameter & thread pitch).
- 2. **TORQUE** all mounting fasteners to appropriate torque value per [Torque Specifications](#).
- 3. **IF** installation is leaning post or deck-mount and deck deflection observed, **THEN VERIFY** following:

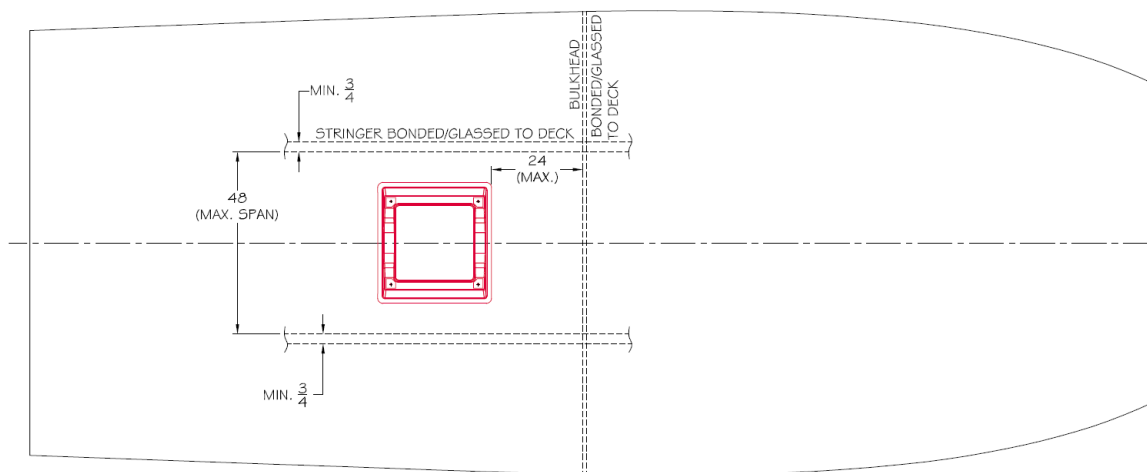

DECK INSTALLATION MINIMUM CONDITION (REFIT)

(NOT TO SCALE)

- a. Table below outlines recommended maximum stringer spacing (deck panel size) and minimum deck build for a deck mount installation of a Seakeeper 2 and 3. These specifications are recommendations and can vary with deck strength and panel size. Regardless of deck specifications, deck should be fully bonded or tabbed to stringers along entire length of panel and transverse bulkhead for deck mount installations with Polybond B39 (1000 psi) or equivalent adhesive.

Seakeeper Model	Longitudinal Stringer Spacing (in / mm)	Distance to Transverse Bulkhead (in / mm)	Deck Laminate & Core Specifications
Seakeeper 2	48 / 1220	24 / 610	1.5 OZ CSNM / E-LTM 1208 / 1.5 OZ CSM / DIVINYLCELL H60 3/4" / 1.5 OZ CSM / E-BXM 1708
Seakeeper 3			

PRODUCT SEAKEEPER SERIES MODELS

Noise & Vibration

4. **IF** verifications in Step 3 were unsatisfactory or deflection of deck observed, **THEN SUBMIT** findings and photos/videos to support@seakeeper.com for review.
5. **IF** evidence of bond failure between saddle and stringers observed on sea trial, **THEN CONTACT** Seakeeper Product Support Team.
 - a. **ORDER** appropriate Saddle Installation Fixture Kit for model affected (partner.seakeeper.com).
 - b. **REMOVE AND DISCARD** mounting fasteners of Seakeeper.
 - c. **LIFT** Seakeeper from saddles.

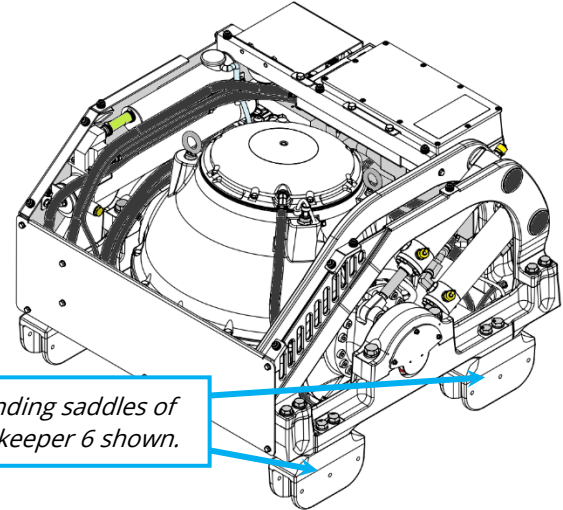
**CAUTION**

DAMAGE TO UNDERLYING STRUCTURE MAY OCCUR if saddles are removed in one piece. Collaborate with Seakeeper Product Support Team before initiating repair.

- d. **DISCARD** original saddles.
 - i. **IF** one saddle found to be compromised, **THEN INSPECT** all saddles. [It is likely failure was due to surface preparation and all saddles would be affected]
- e. **PREPARE** stringers for new saddles as instructed in Bond-In Details Drawings found on [Dealer Access](#) website for appropriate model.
- f. **INSTALL** replacement saddles per instructions provided with bond-in kit.
- g. **RE-INSTALL** Seakeeper on replacement saddles per applicable [Installation Manual](#).

SECTION 3: Internal Enclosure Issues

Most enclosure issues cannot be field serviced. Matters within the enclosure will often require replacement with a refurbished enclosure assembly. Before warranty replacement can be accomplished, video documentation of the noise for frequency analysis will be necessary. If the issue is determined to exist in bearings and the Seakeeper model is engineered for field-replaceable bearings, Seakeeper will contact a dealership with appropriate steps.

Cage rattle or electrical motor noise are sometimes emitted from the Seakeeper during spool up or coast down. These noises typically occur in various speed ranges as the Seakeeper is spooling up or coasting down. At normal operating speed, the noises dissipate and no longer be noticeable. Therefore, cage rattle or electric motor noise do not indicate any imminent failure and is a normal occurrence that does not affect regular operation or performance.

NOTE:

Completing SF-90683 will minimize time and resources should bearing or sphere replacement be required.

1. **IF** noise internal to sphere and still a concern, **THEN RECORD VIDEO** of Seakeeper with smartphone in following manner:
 - a. **OBTAIN** Form SF-90683 from Seakeeper Product Support Team.
 - b. **COMPLETE** as much information on SF-90683 – Pre-FRB Swap Checklist as possible.
 - c. **OBTAIN** video of Seakeeper as follows:
 - i. **MINIMIZE** background noise as much as possible (e.g., no talking, secure engines, and fans). (**NOTE:** If engines cannot be secured on sea trial, it is acceptable to wait until at pier.)
 - ii. **ENSURE** Seakeeper at full RPM when recording video.
 - iii. **POSITION** camera 1 yard (1 meter) from Seakeeper.
 - iv. **MAINTAIN** camera focused on enclosure and background noise to a minimum.
 - v. **RECORD** minimum of 30 seconds of Seakeeper noise.

NOTE:

Compressed video files can lose important audio data.

- d. **SAVE** recording **AND EMAIL** uncompressed video to support@seakeeper.com **OR POST** to Dropbox for engineering analysis.

SECTION 4: Cylinder Alignment

Cylinder misalignment mostly occurs in models that use a trunnion shaft cylinder, as on Seakeeper 6/5, 9/7HD, and 18/16/12HD.

1. **LOOSEN** all cylinder brace fasteners no more than two to three full turns to allow movement of cylinder braces.

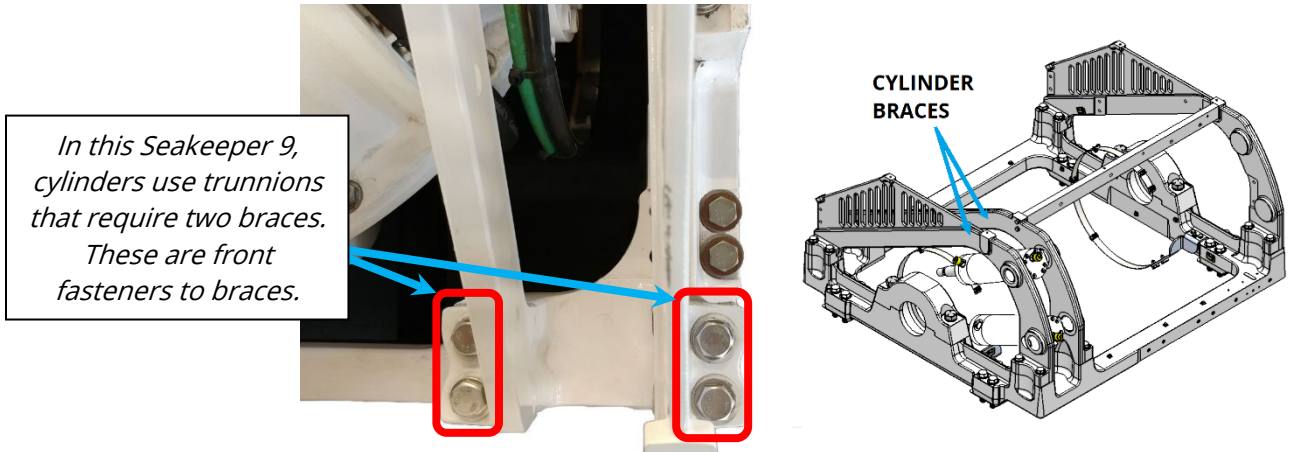

2. **ACTIVATE** brake override.
3. **MANUALLY PRECESS** enclosure fully forward and aft to align rear cylinders in brace(s).
4. **ENSURE** there is freedom of movement (side to side) of each cylinder rear in braces. (**NOTE:** In some cases, a screwdriver may be needed to verify freedom of movement in cylinder rear end. It should NOT require excessive force to obtain slight side-to-side movement in cylinder.)
5. **TORQUE** cylinder brace fasteners to required torque value.

MODEL	CYLINDER BRACE TORQUE
Seakeeper 6/5	50 ft-lbs (68 Nm)
Seakeeper 9/7HD	79 ft-lbs (107 Nm)
Seakeeper 18/16/12HD	80 ft-lbs (109 Nm)

6. **PERFORM** sea trial to ensure all noises/vibrations eliminated.

SECTION 5: Isolation Bushings

Seakeeper recommends the Isolation Bushing Service Kit (P/N 10680) for replacing worn bushings.

**DANGER!**

CRUSHING HAZARD EXISTS when lifting Seakeeper.
Seakeeper 26, 35, and 40 models weigh more than 3000 lbs/1360 Kg weight.

1. **REPLACE** isolation bushings per [SWI-125 - Seakeeper Isolation Bushing Service](#).



2. **PERFORM** sea trial to verify no noise or vibrations.

SECTION 6: Slamming/Clunking/Banging

Slamming/Clunking can be identified by erratic sphere precession. Sometimes, conditions cause the enclosure to knock hard against mechanical or cylinder end stops. Slamming/Clunking can create a harshness transmitted through the hull. The cause of such precession varies. Known causes will be covered.

1. **ENSURE** all checks of Section 1 are complete.
2. **IF** Seakeeper 35 or 40 and GCM software version prior to 10.241,
THEN UPDATE Seakeeper software with Service Tool app **OR REPLACE** GCM.
3. **VERIFY** angle sensor calibration per [SWI-108 - Seakeeper Angle Sensor Calibration](#).
4. **INSPECT** brake cylinder rod ends at gimbals for threads showing at clevis.

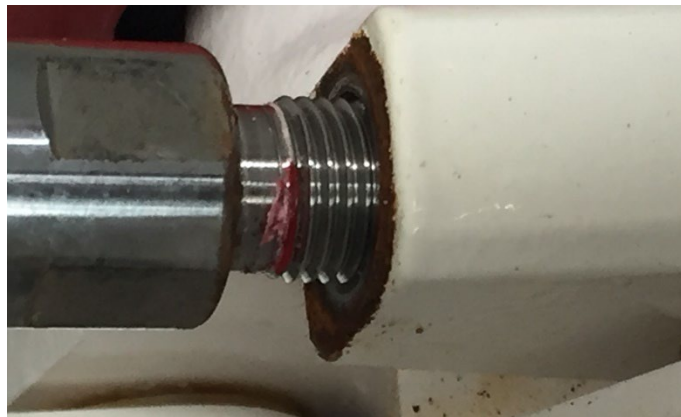

- a. **IF** threads of rod end have backed out,
THEN REPLACE affected brake cylinder(s).
5. **VERIFY** IMU mounted securely and in correct orientation per applicable model Electrical Sub-system drawing or Upper Foundation Assembly drawing on [Dealer Access](#).



PRODUCT SEAKEEPER SERIES MODELS

Noise & Vibration

6. **IF** unit's brake cylinder(s) were recently replaced, **THEN VERIFY** correct hydraulic hose routing per applicable [Brake Sub-system drawing](#) from Dealer Access website.

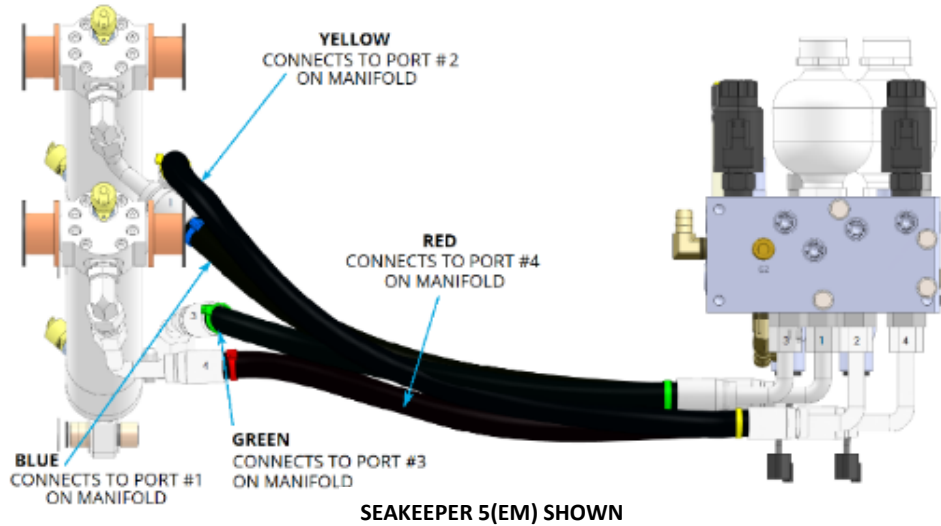

7. **INSPECT** gimbal shaft mounting screw yellow torque marks are aligned.

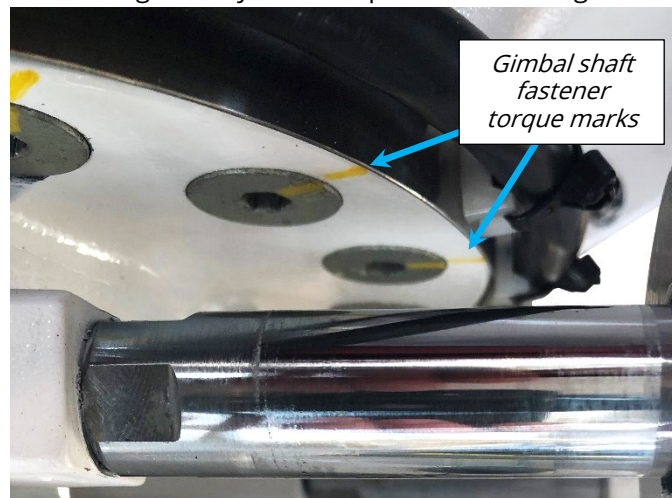

- a. **IF** gimbal fasteners are loose or torque marks not aligned, **THEN CONTACT** Seakeeper Product Support Team at support@seakeeper.com with photos of gimbal shaft and Seakeeper installation in vessel for resolution.

8. **PERFORM** sea trial [using Seakeeper Service Tool app data logger, if available].
9. **IF** slamming/clunking persists through sea trial,
THEN VIDEO Seakeeper with smartphone in following manner:
 - a. **PERFORM** sea trial.
 - b. **ENSURE** Seakeeper at full RPM and in SEA MODE when recording video.
 - c. **MINIMIZE** background noise as much as possible.
 - d. **MAINTAIN** camera focused on enclosure.
 - e. **RECORD** minimum of 30 seconds of sphere precession.
 - f. **PHOTOGRAPH** display or MFD app Information screen of Seakeeper.



NOTE:

COMPRESSED VIDEO FILES CAN LOSE IMPORTANT AUDIO DATA.

- g. **EMAIL** uncompressed video, Service Tool data, and photo(s) to support@seakeeper.com for engineering analysis.

***** **END** *****

CORROSION



To provide guidance in diagnosing cause(s) and refurbishment of corrosion on Seakeeper models.

BACKGROUND

Corrosion is rarely the cause of a service call. Still, it can cause code alarms (loss of angle sensor operation, loss of brake pressure, banging from corroded mounting fasteners, or some electrical codes). Several factors can be at work in a case of heavy corrosion on a Seakeeper: environmental issues such as poor ventilation in the space, seawater spray during boating operations, galvanic problems, and chemical or mechanical disruption of painted surfaces that exposes susceptible metals.

Correcting environmental issues is beyond the scope of this guide. It will be up to the dealer technician and boat owner to correct the issues that caused the corrosion. Educate vessel operator of Seakeeper prescribed occasional freshwater rinse (SB-90106) as a vital part of corrosion prevention.

REFERENCES

[SB-90026 - Paint Touch-up](#)

[SB-90106 - Fresh Water Rinse](#)

[SWI-098 - Ground Connections Various Configurations](#)

Applicable model Installation Manual (See manuals.seakeeper.com)

PRECAUTIONS

See [PRECAUTIONS](#) section of Introduction.

PROCEDURE**SECTION 1: Inspection & Identification**

1. **ENSURE** flywheel at zero RPM at display or MFD app.
2. **TURN OFF** AC or DC high current breaker to Seakeeper.
3. **INSPECT** Seakeeper for severity of corrosion.
 - a. **IF** necessary,
THEN ACTIVATE brake override to manually precess enclosure.
 - b. **RECORD** photographs of corrosion found at critical components for submission with case service report.
 - i. Critical components are those whose failure would create a safety hazard for personnel near Seakeeper.
 1. Gimbal bearings, gimbal caps and shafts
 2. Brake cylinder rear clevises
 3. Brake cylinder rod end pins and clevises
 4. Brake hose fittings
 5. Coolant hose clamps
 - c. **ASSESS** area ventilation/humidity where Seakeeper installed.
 - i. **IF** Seakeeper installed in engine compartment,
THEN ASSUME ventilation is adequate due to regulatory compliance.
 - ii. **IF** Seakeeper installed in a lazarette or other dropdown space,
THEN ENSURE natural ventilation is available, at a minimum.
 - iii. **IF** mildew or lack of ventilation exists in space,
THEN INFORM vessel operator of ventilation appliances available for space.



Seakeeper 3 with severe corrosion at rod end clevises, pins, and gimbal shafts

Section 1, Step 3 continued

- d. **EVALUATE** source of any liquids seen, or evidence of, dripping onto Seakeeper.
 - i. **INSPECT** overhead hatch seals for deterioration.
 - ii. **INSPECT** overhead pipes for condensation or leakage.
 - iii. **INSPECT** space for high bilge levels.
- e. **INSPECT** for evidence of submersion on Seakeeper.



- 4. **INSPECT** electrical connections of wire harness for corrosion and moisture intrusion.
- 5. **REMOVE** angle sensor mounting plates **AND CHECK** for excessive corrosion on gimbal shaft.
- 6. **VERIFY** following ground cable ends are securely fastened:
 - a. Heat exchanger to foundation ground.
 - b. Motor drive to frame/foundation ground.
 - c. AC-powered models enclosure to foundation ground.
 - d. Foundation to vessel negative ground or bonding system.
- 7. **IF** DC-powered model,
THEN VERIFY motor drive terminals not corroded.
 - a. **IF** corrosion found,
THEN:
 - i. **CLEAN** terminals and cable ends.
 - ii. **APPLY** dielectric grease to terminal fasteners and cable ends.

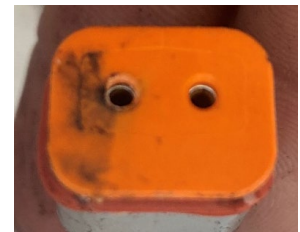

Evidence of moisture intrusion in a harness connector

SECTION 2: Restoration

In severe cases of corrosion, such as when a unit has been submerged, it will be necessary to replace the Seakeeper. Additionally, if severe corrosion is due to environmental issues in the space, the Seakeeper may require removal for a complete restoration in a shop area. Reinstallation should always follow guidelines outlined in the applicable model's Installation Manual. Installation manuals can be found at manuals.seakeeper.com.

1. **ENSURE** flywheel at zero RPM at display or MFD app.
2. **DEENERGIZE** all power to Seakeeper.
3. **REMOVE** top cover panels from Seakeeper.
4. **REPLACE** components that are corroded beyond reasonable restoration.
 - a. **IF** multiple components corroded beyond restoration, **THEN CONTACT** Seakeeper Product Support Team at support@seakeeper.com to consider other options.
 - b. **IF** brake hose fittings are severely corroded, **THEN REPLACE** brake hoses.



With corrosion this severe, restoration may be futile in stopping leaks and preventing future low brake pressure alarms.



- c. **IF** brake pin hardware is corroded (pin retaining rings) or severe corrosion around brake pins, **THEN REPLACE** brake pin hardware and all bushings per [SWI-109](#).



Section 2, Step 4 continued

- d. **IF** indication of corrosion at an AC-powered Seakeeper Motor Drive, **THEN REMOVE** Motor Drive cover **AND INSPECT** drive internal surfaces.
 - i. **IF** any evidence of corrosion or moisture intrusion present, **THEN REPLACE** motor drive per [SWI-094](#).



- e. **IF** electronic components discovered with severe corrosion, **THEN REPLACE** affected components, as needed.
- f. **REPLACE** other components as necessary.



PRODUCT SEAKEEPER SERIES MODELS

Corrosion

5. **IF** vessel used mainly in fresh water, **THEN CONSIDER** changing zinc anodes of heat exchanger with magnesium rods.

6. **IF** corrosion excessive at gimbal bearings, **THEN:**

- a. **REMOVE** gimbal angle mounting plate.
- b. **INSPECT** ends of gimbal shaft for corrosion at sensor magnet and bearing.

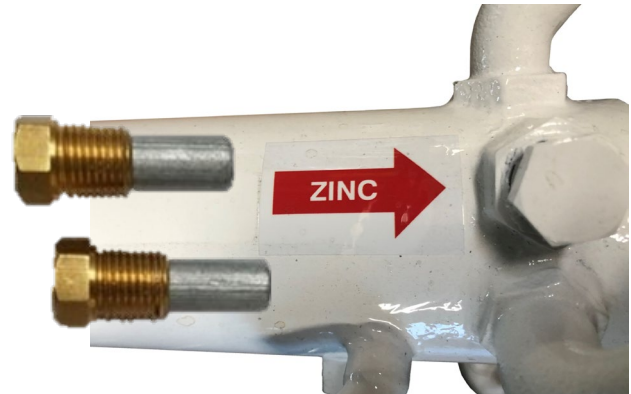

7. **REMOVE** as much rust possible with wire brush and scraper at affected areas.

8. **CLEAN** Seakeeper surfaces and electrical connectors

9. **SAND** surfaces to be painted with 220 grit sandpaper.

10. Using lint-free rags and acetone, **CLEAN** all surfaces to be painted.

11. Once all surfaces clean, **APPLY** mixture of Awlgrip® S9001 primer and Awlgrip® S3001 converter to exposed metal surfaces.

12. **WHEN** primer has dried, **THEN APPLY** approved topcoat mixture:

TOPCOAT: Awlgrip® F8063 (Snow white)	TOPCOAT: Alexseal® Topcoat 501 (snow white GL) (P/N: AYCT9134G)
CATALYST: Awlgrip® Topcoat Converter G3010	CATALYST: Alexseal® Topcoat Converter spray GL (P/N: AYCC5051G)

13. **ENSURE** all Seakeeper grounds are secured per [SWI-098](#).

14. **EDUCATE** vessel operator of benefits of freshwater rinse per [SB-90106](#).

******* END *******

PERFORMANCE ISSUES



To address issues associated with an installed Seakeeper configuration's inability to meet roll reduction expectations based on Performance Prediction (PP) Report or customer expectations in a representative sea condition and corresponding uncontrolled roll angle.

BACKGROUND

Troubleshooting for all performance-related issues should start with reviewing a PP Report for the vessel in question and confirming that the vessel characteristics accurately reflect the complete load condition for the boat. The PP Report will estimate the expected performance for various Seakeeper configurations based on uncontrolled angle, which must meet a minimum criterion for Coastal or Offshore performance standards per the report. For example, for Coastal Operation, Seakeeper recommends 80% roll reduction at 10 deg of uncontrolled roll with a minimum of 80% roll reduction at 6 deg. For Offshore Operation, the recommended roll reduction is 80% at 15° of uncontrolled roll with a minimum of 80% at 10 deg. Uncontrolled roll motion is a function of the vessel's sea state and resonant roll period.

Each report will have a Recommended Configuration and might provide additional configurations between the minimum and recommended performance levels. Customer expectations should be set based on the PP Report results for the installed Seakeeper configuration.

When the Seakeeper configuration is below the recommended level, the roll reduction will be adversely affected and reduced as the sea state (uncontrolled roll angle) increases. Seakeeper encourages all installers to select a configuration that meets or exceeds our recommendation for a vessel's operating profile. These recommendations may be ignored for several reasons: economy, space availability, weight allowance, or an owner's acceptance of lowered roll-reduction performance.

Where the installed configuration meets or exceeds the Seakeeper recommendation per PP Report, the vessel characteristics should be confirmed for accuracy, as the report is only as good as the information provided. If vessel specifications are confirmed to be accurate, performance issues could be caused by numerous factors. There could be an issue with the Seakeeper electronics or software, such as how the GCM software interprets the IMU input or what data the IMU transmits to the GCM could be at fault.

A Seakeeper unit may have installation issues, be inappropriately connected to an NMEA network, or may have had vessel modifications that changed the original vessel configuration.

REFERENCES

[Sea Trial App Users Guide](#)

[SWI-118 - Seakeeper Service Tool App User Guide](#)

Applicable model Electrical Sub-system or Assembly drawing on [Dealer Access](#)

PRECAUTIONS

See [PRECAUTIONS](#) section of Introduction.



PROCEDURE

1. **INTERVIEW AND RECORD** vessel owner/captain responses to following questions:

NOTE:

Addition of 10% of vessel weight can adversely affect performance.

- a. Were any modifications made to vessel before performance issue noted? If so, what modifications were performed?
(i.e., add weight, changes to primary machinery, or hull modifications)

- b. Was vessel recently purchased? If so, was it new?

If new: Make: _____, Model: _____
- c. When did performance first appear degraded? What else changed at that time?

- d. What sea and operating conditions were experienced when performance first appeared degraded?

- e. Was flywheel at target RPM when performance seen degraded? _____

2. **CALCULATE** boat Seakeeper sizing using Small Boat Sizing Guide or Sizing Program to create a PP Report. Contact Sales Rep for published reports on OEM Seakeeper installations.
3. **TURN OFF** AC or high current DC power breaker.
4. **ENSURE** flywheel at zero RPM at display or MFD app.

5. **INSPECT** Seakeeper:**NOTE:**

GCM software 11.140 and after with ConnectBox software 3.3.8 and after will store cleared alarms in memory accessible through Service Tool app.

- a. **REVIEW** alarm history at display or MFD app.
 - i. **ADDRESS** motion-related alarm codes per applicable troubleshooting guide (Codes 19, 26, 27, 37, 38, 39, 50, 55, 56, 72, 76, 78, 79, 80, 111, or 115).
 - ii. **RECORD** alarms in history.
- b. **PHOTOGRAPH** display Information screen.
- c. **CHECK** for proper mounting screw torques per [Torque Specifications](#) section.
- d. **IF** Seakeeper 6, **THEN ENSURE** aluminum spacers installed at each corner of foundation.
- e. **ENSURE** IMU mounted securely to panel by two bolts and nuts.
- f. **ENSURE** IMU housing is intact and no cracks present.
- g. **ENSURE** panel to which IMU mounted is securely fastened to foundation.
- h. **ENSURE** IMU mounted in correct orientation per applicable model Electrical Subsystem or Assembly drawing.



PRODUCT SEAKEEPER SERIES MODELS

Performance

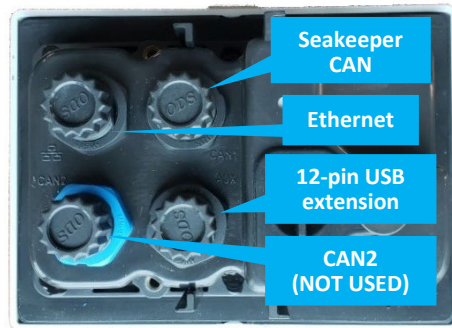
6. At display or ConnectBox, **ENSURE** following:a. For 5" display, **ENSURE** NO additional connections on back panel than shown.7. For ConnectBox, **ENSURE** NMEA2000 connection at correct location.8. **PERFORM** sea trial:a. **SET-UP** Seakeeper Service Tool app to run data log for sea trial per [SWI-118](#).b. **IF** dealership does not have Seakeeper Service Tool app,
THEN RUN Seakeeper Sea Trial App on a smartphone during sea trial.i. Seakeeper Sea Trial App is available on [Apple App](#) or [Google Play](#) stores.ii. **USE** Seakeeper [Sea Trial App Users Guide](#) for installation and use of app.c. **COMPLETE** sea trial recordings, 10 min. with Seakeeper(s) unlocked (on) and 10 min. with Seakeeper(s) locked (off).d. **SUBMIT** Sea Trial Report by linking recordings and completing required information in app.e. **EVALUATE** Seakeeper performance based on app results.f. **OBSERVE** sphere enclosure precession while in Sea Mode.i. **IF** precession is abnormal (erratic or enclosure remains to one side),
THEN VIDEO RECORD Seakeeper while precessing.9. **IF** issue not found or assistance needed,**THEN SUBMIT** all images, recordings, data log file(s), and interview responses to Seakeeper Product Support Team at support@seakeeper.com for review.***** **END** *****



TORQUE SPECIFICATIONS



TORQUE SPECIFICATIONS							
Seakeeper Model	Gimbal Bearing Cap	Gimbal Shafts	Cylinder Braces	Mounting Screws ³	Water Jackets	Bump Stop Screws	Motor Drive
	ft-lbs (Nm) Socket Size	ft-lbs (Nm) Socket Size	ft-lbs (Nm) Socket Size	ft-lbs (Nm) Socket Size	in-lbs (Nm) Socket Size	ft-lbs (Nm) Socket Size	
2	60 (82) 17 mm	30 (41) 6 mm Allen	60 (82) 17 mm	135 (183) 22 mm	90 (10) 10 mm	N/A	Battery Terminal 97 (11) Motor Terminal 29 (3.3)
3	70 (95) 19 mm	50 (68) T-50 Torx	60 (82) 17 mm	155 (210) ¹ 24 mm	90 (10) 10 mm	N/A	
5/6	140 (190) 24 mm	50 (68) 8 mm Allen	50 (68) 19 mm	95 (129) ² 19 mm	72 (8) 10 mm	25 (34) 17 mm	Cover Screws 19 (2.2)
9	200 (272) 1-1/8"	130 (176) 12 mm Allen	79 (107) 19 mm	100 (136) 22 mm	150 (17) 13 mm	N/A	
16/18	200 (272) 1-1/8"	130 (176) 12 mm Allen	80 (109) 19 mm	100 (136) 22 mm (Use anti-seize – No thread lock)	150 (17) 13 mm		
26	400 (544) 1-1/2"	100 (135) 1/2" Allen	60 (82) 19 mm	100 (136) 24 mm	150 (17) 13 mm		
35	400 (544) 1-1/2"	100 (135) 1/2" Allen	100 (135) 19 mm	100 (136) 24 mm	120 (14) 1/4" Allen		
40	400 (544) 1-1/2"	100 (135) 1/2" Allen	100 (135) 19 mm	100 (136) 24 mm	150 (17) 13 mm		

1. Seakeeper 3 units before serial no. 3-3836 have mounting screw torque of 135 ft-lbs (183 Nm)
 2. Seakeeper 6 /5 units before serial no. 6/5-5365 have mounting screw torque of 65 ft-lbs (88 Nm)
 3. Earlier models may have lower torque values. Check associated Enclosure drawing for earlier models.

BRAKE HOSE FITTINGS						
Seakeeper Model	Cylinder Bleed Ports		Cylinder Fittings		Hose Fittings	
	ft-lbs (Nm)	Wrench	ft-lbs (Nm)	Wrench	ft-lbs (Nm)	Wrench
2 & 3	15-18 (20.3-24.4)	11/16"	26-31 (35.3-42)	11/16"	22 (29.8)	11/16"
6/5 thru 18	17-19 (23-25.8)	11/16"	40 (54.2)	7/8"	40 (54.2)	7/8"
26, 35, & 40	7-8 (9.5-12.2)	5/8"	40 (54.2)	7/8"	40 (54.2)	7/8"

SPHERE DIMENSIONS*								
Parameter	Seakeeper Model Number							
	2	3	6/5	9	18	26	35	40
Sphere weight (lbs / kg)	340 / 154	450 / 205	690 / 313	995 / 452	2100 / 953	2460 / 1116	3233 / 1467	3258 / 1478
Sphere dimensions H x W (in. / cm)	18.8 x 18.8 / 47.71 x 47.5	21.3 x 20.3 / 54.1 x 51.5	23.1 x 21.3 / 58.62 x 54.1	26.6 x 25.1 / 67.6 x 64	32 x 30.2 / 81.26 x 76.7	36.1 x 34.5 / 91.5 x 87.5	38.8 x 34.3 / 98.5 x 86.9	36.9 x 34.5 / 93.5 x 87.5
Sphere width less gimbal shafts (in. / cm)	17.4 / 44.2	19.13 / 48.6	20.4 / 51.8	24 / 61	29.75 / 75.6	33.25 / 84.5	32.46 / 82.4	32.4 / 82.2
Sphere weights	304	434	702	1012	1890	2482	3300	3324

* Most dimensions are rounded up conservatively.