




# **SEAKEEPER**

## ***INSTALLATION MANUAL***



**SEAKEEPER®**

**2**

 <b>SEAKEEPER</b>	<b>INSTALLATION MANUAL</b>	<b>Product:</b>	<b>Document #:</b>	<b>Rev:</b>
		<b>SEAKEEPER 2</b>	<b>90488</b>	<b>2</b>

# **SEAKEEPER 2**

# **INSTALLATION MANUAL**

## **JUNE 2018**

### **Contents:**

**Section 1 – Mechanical Installation**

**Section 2 – Electrical Installation**

**Section 3 – Cooling Installation**

**Section 4 – Startup**

**Section 5 – Installation Checklist and Required Supplies**



**44425 PECAN COURT, SUITE 151**

**CALIFORNIA, MARYLAND, 20619, U.S.A**

**PHONE: 410-326-1590**

**FAX: 410-326-1199**

**E-MAIL: [customerservice@seakeeper.com](mailto:customerservice@seakeeper.com)**

**Section 1: MECHANICAL INSTALLATION**

## 1.0 Introduction

This document is intended to give details and guidance to a boat builder or equipment installer to install the Seakeeper 2. The Seakeeper 2 is capable of producing loads up to 6.49KN (1,459 lbs.) at each of the four mounts and careful consideration should be given to foundation design to insure it is capable of transferring these loads into the hull. These loads do NOT include vessel motion accelerations, such as vertical slam loads which can be high for higher speed vessels.

There are two methods of installing the Seakeeper 2:

- 1) Longitudinal Bolt-In Installation
- 2) Transverse Bolt-In Installation

**It is assumed that the installer is familiar with mounting using mechanical fasteners to marine structures and has performed structural analysis to assure the structure to which the Seakeeper mounts can properly transfer the loads the Seakeeper creates into the hull structure. If the installer has any doubt about the ability of the structure to transfer the loads to the hull then the installer should contact a licensed naval architect or marine engineer to do a structural analysis.**

The installer should review the following list of reference drawings to ensure the installation procedure is fully understood.

### Reference Drawings

**90469 Seakeeper 2 Hardware Scope of Supply**

**90487 Seakeeper 2 Installation Details – Bolt in Method**

**90490 Seakeeper 2 Cooling Water Schematic**

**90473 Seakeeper 2 Installation Template Kit**

**90470 Seakeeper 2 Cable Block Diagram**

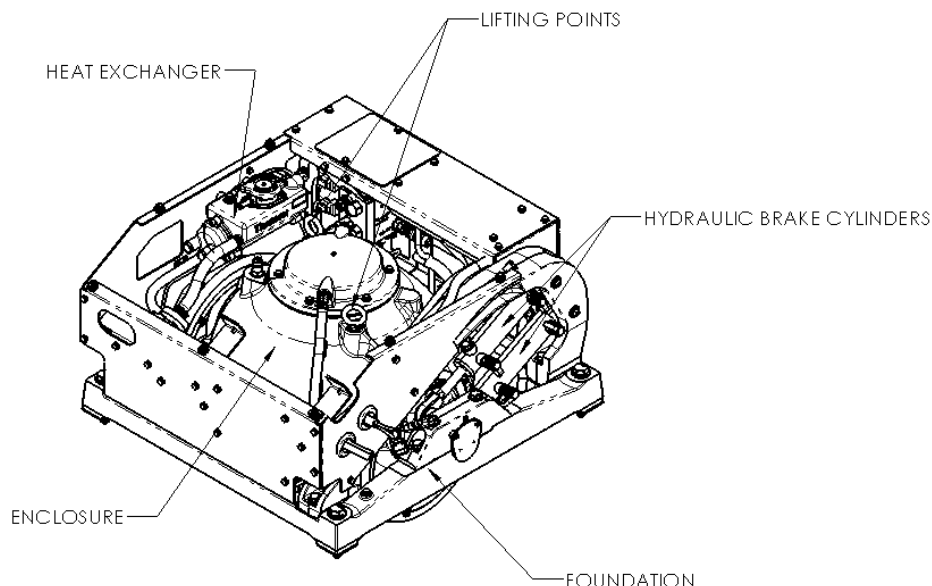


FIGURE 1 – SEAKEEPER 2

**Section 1: MECHANICAL INSTALLATION**

## 1.1 Precautions

- The Seakeeper must only be lifted from the supplied lifting eyes (See Section 1.3).
- The Seakeeper flywheel is supported by precision bearings. Make certain while unpacking and lifting the Seakeeper assembly to NOT drop or impart mechanical shock as damage to bearings could result.
- While handling / installing the Seakeeper assembly, protect exposed hydraulic brake cylinder rods (See Figure 1) from scratches or damage as this could lead to premature seal failure and oil leaks.
- While handling / installing the Seakeeper assembly, do not allow electrical fittings that exit bottom of the Seakeeper enclosure to come in contact with any surface or object as this could damage the fittings and potentially affect the vacuum integrity of the enclosure.
- Exercise care to protect the painted finish as damage to finish could lead to early appearance degradation of the installed Seakeeper.

## 1.2 Selection of Seakeeper Installation Location

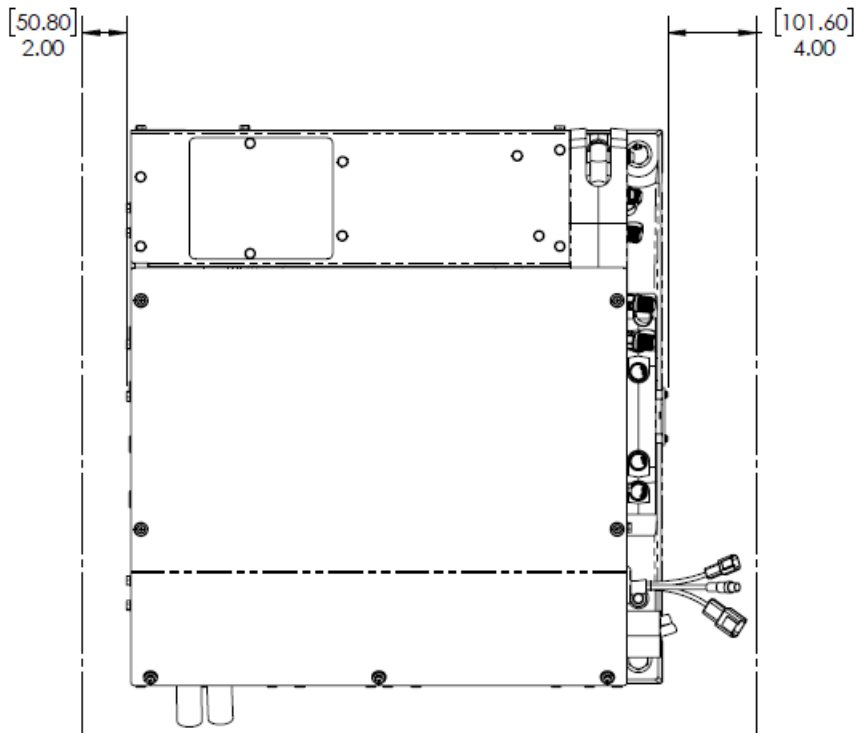
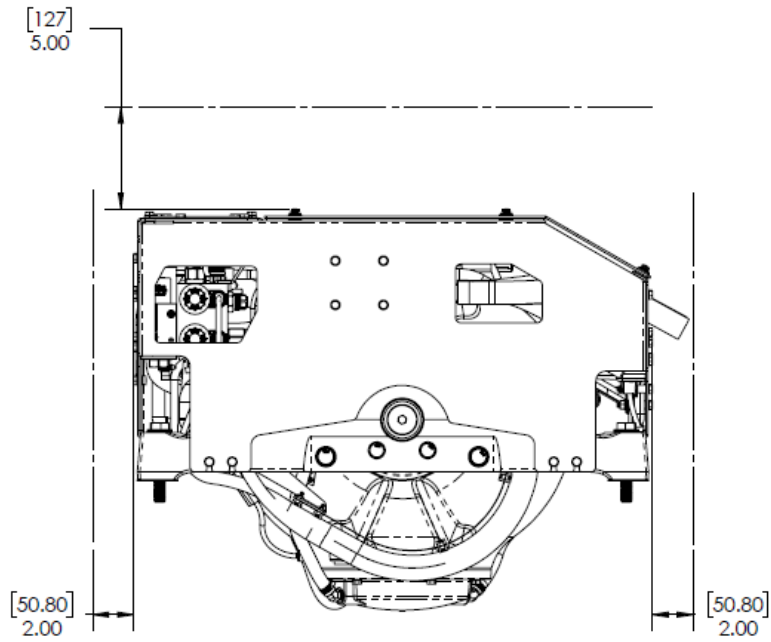
Selection of mounting location of the Seakeeper should consider the following desirable features:



**The Seakeeper should be installed aft of amidships to minimize high acceleration loadings due to hull/wave impacts during operation at high speed or in large waves. If the only possible Seakeeper location is forward of amidships then the installer should have Seakeeper review the installation location prior to finalizing the design.**

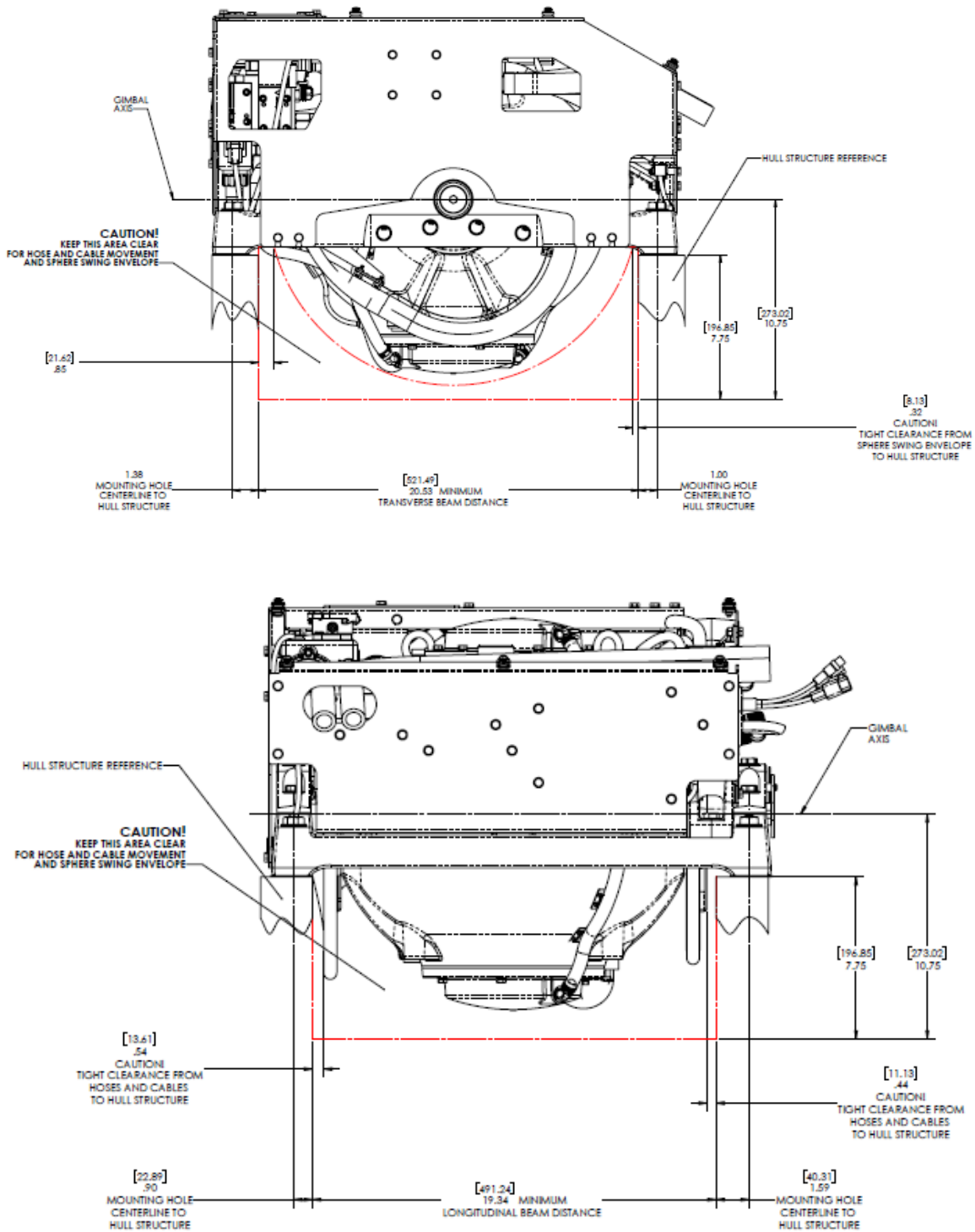
- **Top down access or sufficient clearance for removal / re-installation of the Seakeeper for overhaul in future years.**
- The Seakeeper should be installed in a dry space to minimize effects of corrosion.
- Clearance for all recommended scheduled maintenance and any repairs that may be necessary (see Figure 2).

**Section 1: MECHANICAL INSTALLATION**



**VIEWS SHOWING RECOMMENDED CLEARANCES AROUND THE SEAKEEPER FOR USE OF HANDTOOLS, EASE OF MAINTENANCE, INSTALLATION, AND PROPER OPERATION.**

**FIGURE 2 – INSTALLED SEAKEEPER CLEARANCE CONSIDERATIONS**

**Section 1: MECHANICAL INSTALLATION**

**FIGURE 3 – BEAMS CLEARANCE CONSIDERATIONS**

Refer to Figure 3 for recommended clearances to transverse or longitudinal beams. Clearances aft of the Seakeeper are shown to provide access for regular scheduled maintenance.

**Section 1: MECHANICAL INSTALLATION****Safety**

There is a large torque about the gimbal axis when the Seakeeper is precessing. Seakeeper cover panels are provided to prevent personnel or equipment from contacting the Seakeeper while it is in operation. These covers should not be stepped on or have anything placed on top. The covers should always be in place during operation. If it is ever necessary to access the Seakeeper while the flywheel is spinning, the Seakeeper must be locked at the display to stop the Seakeeper from precessing. Seakeeper regular scheduled maintenance should not be attempted unless the Seakeeper is locked and the flywheel has stopped spinning.

The Seakeeper should be treated with the same respect one gives a high speed rotating propeller shaft or engine shaft.

**Noise/Soundproofing**

Seakeeper noise has been measured under steady state conditions (no wave load) in Seakeeper's lab and in our test boat. The steady state noise at 1 meter is typically in the range of 64-68 dBC un-weighted. As the frequencies emitting the highest sound pressures are low (like other marine machinery), it is recommended that the Seakeeper be installed in a machinery space that is already treated with soundproofing.

**Section 1: MECHANICAL INSTALLATION**

## 1.3 Transport and Unpacking

### 1.3.1 Transport

- 1) Use a Seakeeper provided shipping crate for transport, part number 11851. Overall dimensions of a fully packed crate are 36.25"Lx35.75"Wx38"H with a weight of 482 lbs(219kgs).
- 2) Do not stack Seakeeper shipping crates.
- 3) Both Air and Ground transport are acceptable.
- 4) Seakeeper shipping crates must be transported in environmental conditions between -20°C and 60°C.

### 1.3.2 Unpacking Crate

- 1) Reference Seakeeper Drawing No. 90469, Seakeeper 2 Hardware Scope of Supply for items that ship with the corresponding Seakeeper model.
- 2) Remove covers, electrical components, display, cables, and misc. items and set aside.
- 3) Remove packing materials that secure Seakeeper assembly inside the crate.
- 4) Attach spreader bar (Seakeeper P/N 11766; available for purchase) to the two lifting eyes located on the top of the Seakeeper enclosure. Stay clear of any other parts on the Seakeeper. The Seakeeper 2 weighs 188 kg (414 lbs). See Figure 4 below.

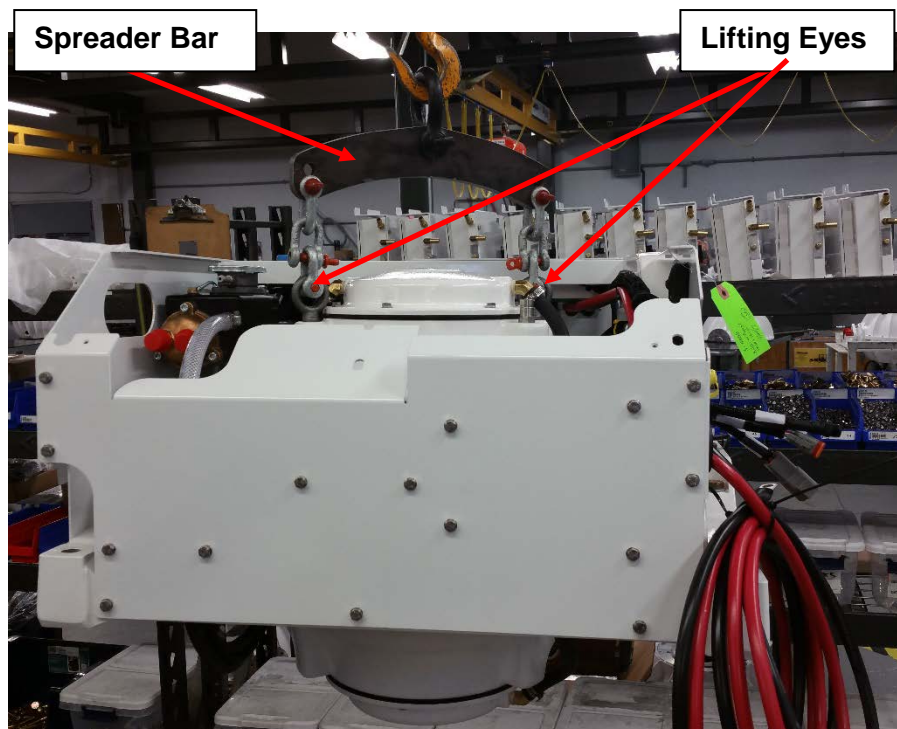


FIGURE 4 – LIFTING ARRANGEMENT



**Section 1: MECHANICAL INSTALLATION**

## 1.4 Longitudinal Bolt-In Installation

### 1.4.1 Check and Preparation of Hull Structure

The Seakeeper 2 can be affixed to the hull structure using two methods 1) Longitudinal Beam Bolt-In installation or 2) Transverse Beam Bolt-In installation. Neither option affects the operation of the Seakeeper. However, one option might ease the installation process or allow for a larger service envelope. Depending on the structure to which the Seakeeper is fastened, blind threaded holes or thru-bolting can be utilized.

Refer to Seakeeper **Drawing No. 90487, Seakeeper 2 Installation Details – Bolt in Method**. Important dimensional and load information is given in this drawing that will impact the design details of the structure that will receive the Seakeeper. It is assumed that a proper structural analysis has been performed for the hull structure to which the Seakeeper will be fastened to insure proper strength margins for the loads the Seakeeper will create during operation.

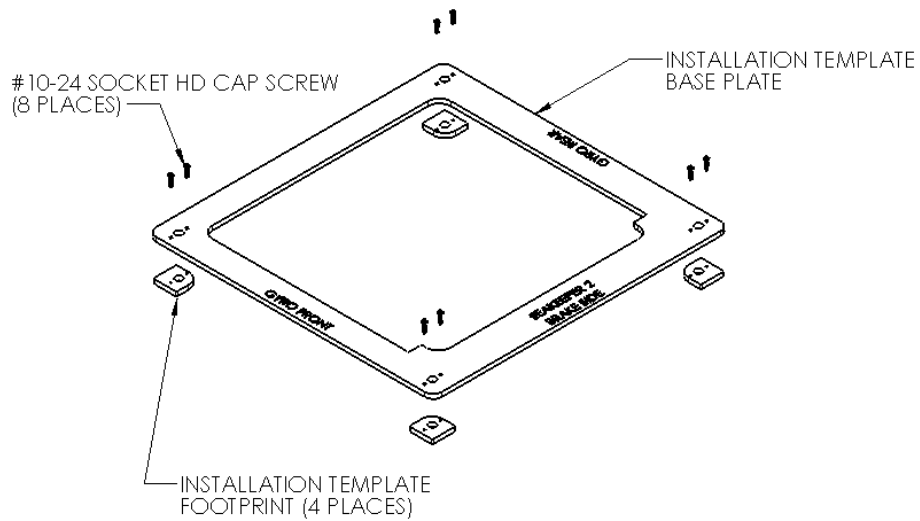
The hull structure supporting the Seakeeper should be installed so the Seakeeper is parallel to the waterline. **In addition, the four areas on top of the beams on which the feet of the Seakeeper foundation and isolation gaskets will rest, need to be co-planar within .06” (1.5 mm) to minimize potential distortion of Seakeeper support frame when installed. The isolation gaskets are only used on dissimilar metal to metal contacts**

Seakeeper offers an optional installation template kit, P/N 90473, which contains four plates that mimic the mating surfaces of the four feet located on the Seakeeper's foundation. These plates have 4 holes located at the same centers as the mounting holes on the Seakeeper. The fixture locates the hole patterns at the proper spacing both in the fore-aft direction and the port-starboard direction. See Figures 5 below. Once assembled, the fixture can be used to check clearances and alignment of the hull structure.

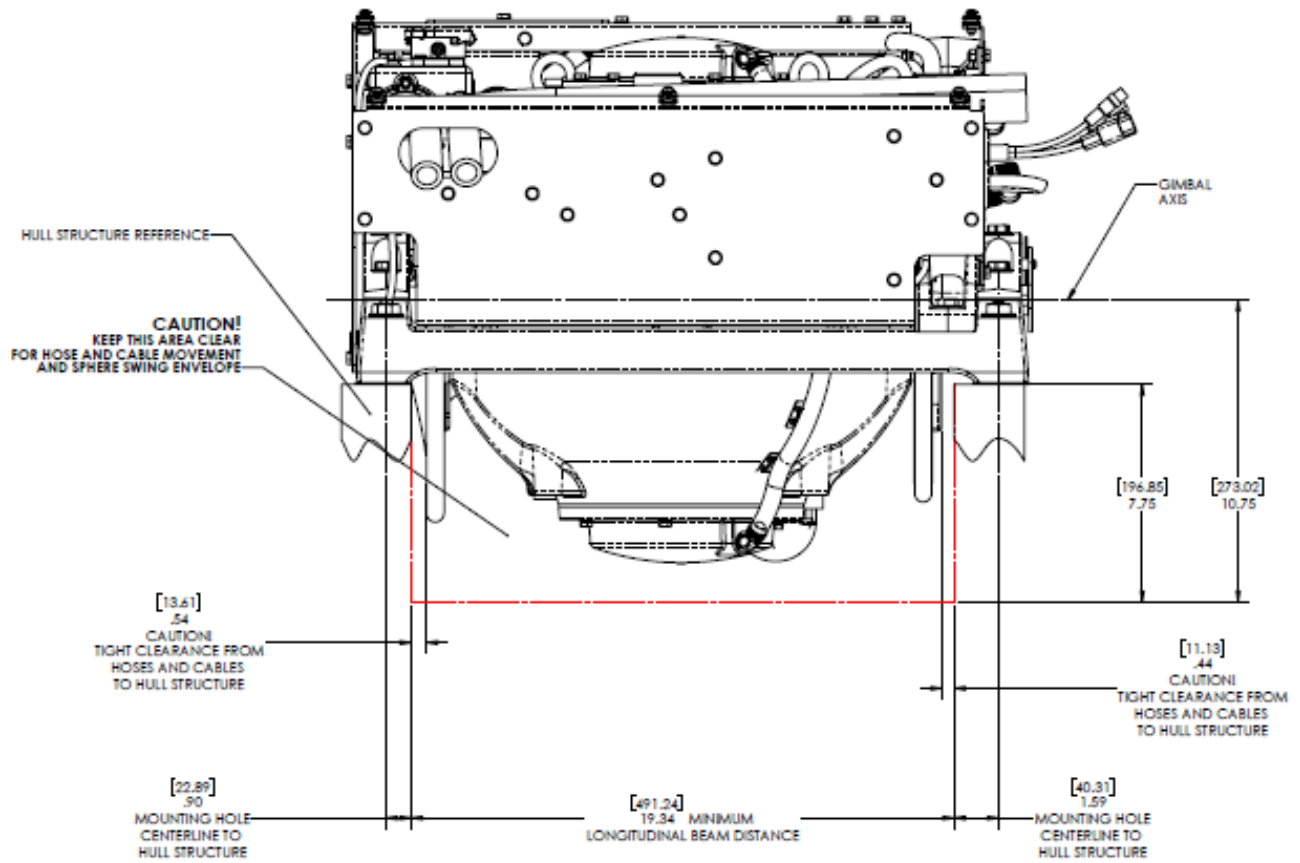
**Note: Do NOT use the installation fixture to establish the Seakeeper envelope dimensions. Refer to Drawing No. 90487 for envelope dimensions. A 3-D model of the Seakeeper is available on the Seakeeper website ([www.seakeeper.com](http://www.seakeeper.com)) to aid in designing the Seakeeper foundation and the space around the Seakeeper.**

**NOTE: MAKE SURE NO OBSTRUCTIONS FROM THE HULL STRUCTURE CAN BE SEEN WITHIN THE INSIDE OF THE INSTALLATION TEMPLATE KIT (INSIDE THE MARKED RED LINES). REFERENCE SEAKEEPER DRAWING NO. 90487.**

**Section 1: MECHANICAL INSTALLATION**



**FIGURE 5 – EXPLODED VIEW OF INSTALLATION FIXTURE**

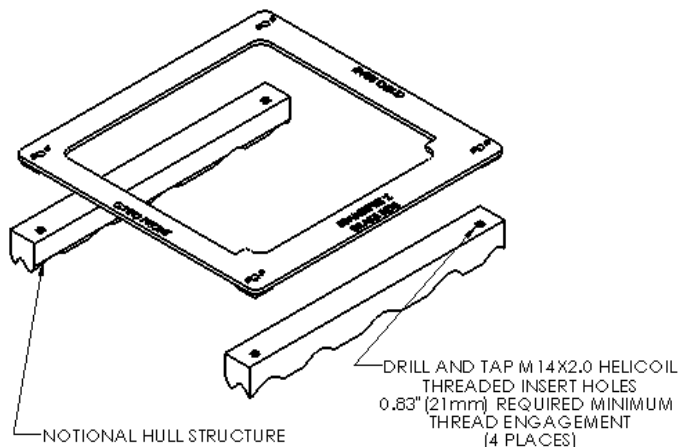
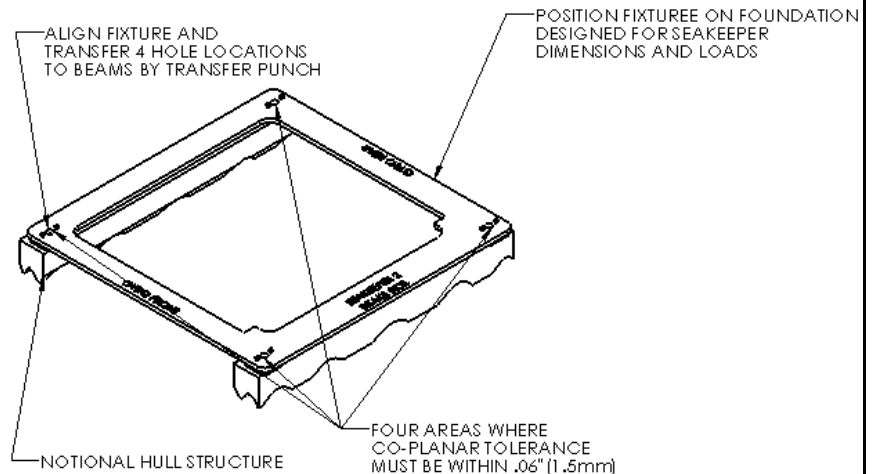


**CAUTION: Tight clearances from cable guide bands to hull structure. See above figure for dimensions and reference Seakeeper drawing NO. 90487 for complete Seakeeper 2 envelope.**

**Section 1: MECHANICAL INSTALLATION**

## 1.4.2 Transfer of Holes to Boat Structure

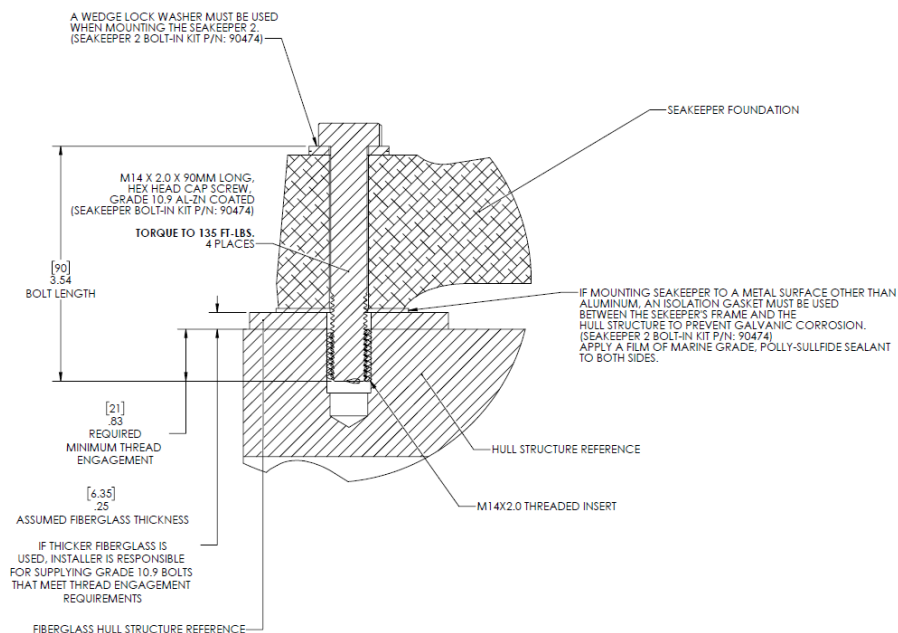
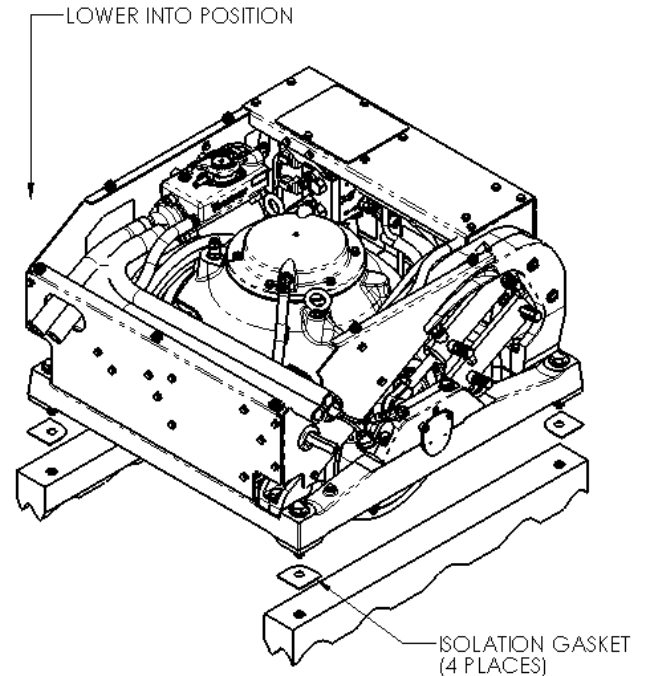
- 1) Lower assembled fixture onto hull structure.
- 2) **The four areas where the feet of the Seakeeper will rest should be coplanar to within .06" (1.5 mm). See Figure 10.**
- 3) Align fixture in desired location and transfer holes from fixture plate to the hull structure. Note that holes in fixture plate are  $\varnothing 0.60$  (15.138 mm).
- 4) Remove fixture and drill and tap M14X2.0 Helicoil threaded insert holes in hull structure at marked locations to mate with holes in the Seakeeper foundation. **Take special care to drill perpendicular to mounting surface.** A drill guide is recommended. Remove any impeding obstructions.



**Section 1: MECHANICAL INSTALLATION**

### 1.4.3 Installation of Seakeeper

- 1) Locate and position 4 isolation gaskets onto foundation beams (for metal to metal contacts only). NOTE: Sealant or caulk is recommended to be applied. Apply a small bead (approximately 4 mm wide) of sealant (silicone or caulk) between both mating surfaces of each isolation gasket where it contacts the beam and the Seakeeper. This will prevent water from wicking between the parts and setting up corrosion. Check isolation gasket alignment by test fitting bolts without any obstructions.
- 2) Lower Seakeeper into position onto the hull foundation beams and align over drilled holes.
- 3) Install Seakeeper supplied M14 fasteners Or Grade 10.9, M14-2.0 bolts to maintain a **minimum thread engagement of .83 in (21 mm)** – **apply a moderate coat of removable thread locker to the threads** of each bolt and include a small bead of sealant under each washer before installation.
- 4) **Torque all fasteners to 135 ft-lbs (183 N-m). New, Seakeeper supplied bolts must be used for each installation and reinstallation.**
- 5) Proceed to electrical and cooling portion of the installation.



**Section 1: MECHANICAL INSTALLATION**

## 1.5 Transverse Bolt-In Installation

### 1.5.1 Check and Preparation of Hull Structure

The Seakeeper 2 can be affixed to the hull structure using two methods 1) Longitudinal Beam Bolt-In installation or 2) Transverse Beam Bolt-In installation. Neither option affects the operation of the Seakeeper. However, one option might ease the installation process or allow for a larger service envelope. Depending on the structure to which the Seakeeper is fastened, blind threaded holes or thru-bolting can be utilized.

Refer to Seakeeper **Drawing No. 90487, Seakeeper 2 Installation Details – Bolt in Method**. Important dimensional and load information is given in this drawing that will impact the design details of the structure that will receive the Seakeeper. It is assumed that a proper structural analysis has been performed for the hull structure to which the Seakeeper will be fastened to insure proper strength margins for the loads the Seakeeper will create during operation.

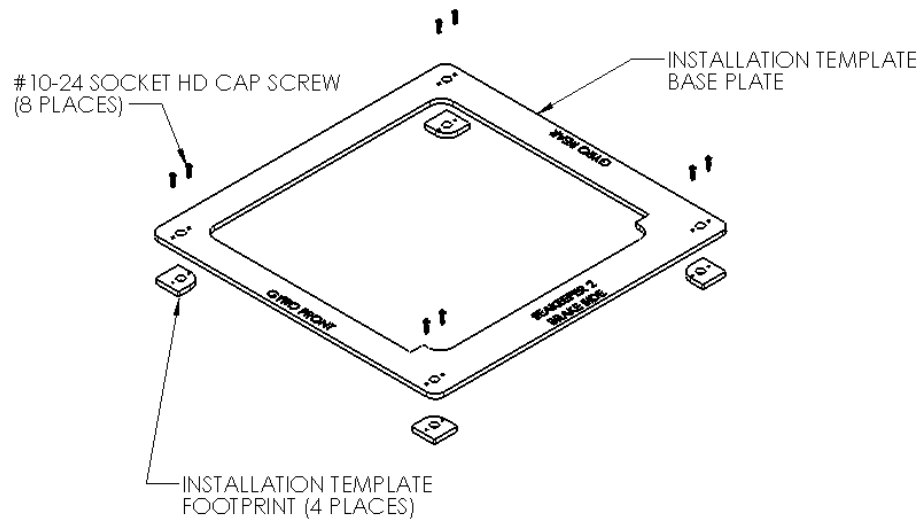
The hull structure supporting the Seakeeper should be installed so the Seakeeper is parallel to the waterline. **In addition, the four areas on top of the beams on which the feet of the Seakeeper foundation and isolation gaskets will rest, need to be co-planar within .06” (1.5 mm) to minimize potential distortion of Seakeeper support frame when installed. The isolation gaskets are only used on dissimilar metal to metal contacts**

Seakeeper offers an optional installation template kit, P/N 90473, which contains four plates that mimic the mating surfaces of the four feet located on the Seakeeper's foundation. These plates have 4 holes located at the same centers as the mounting holes on the Seakeeper. The fixture locates the hole patterns at the proper spacing both in the fore-aft direction and the port-starboard direction. See Figures 5 below. Once assembled, the fixture can be used to check clearances and alignment of the hull structure.

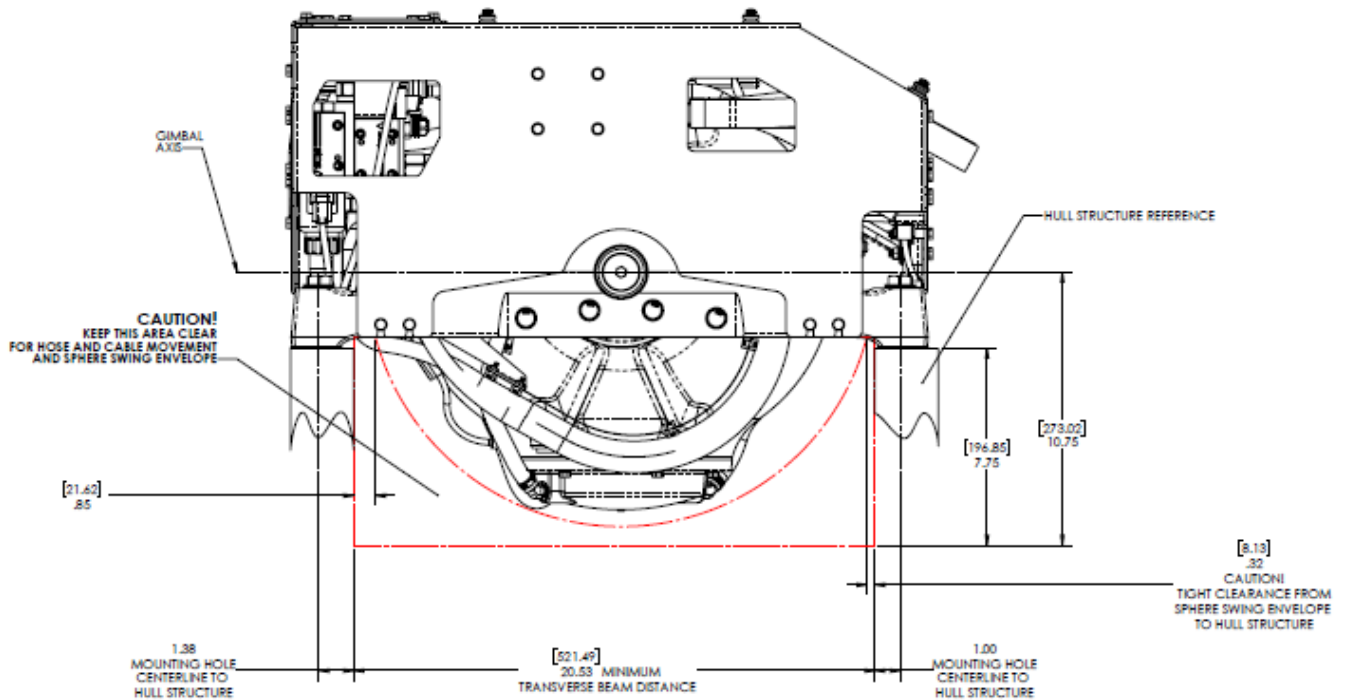
**Note: Do NOT use the installation fixture to establish the Seakeeper envelope dimensions. Refer to Drawing No. 90487 for envelope dimensions. A 3-D model of the Seakeeper is available on the Seakeeper website ([www.seakeeper.com](http://www.seakeeper.com)) to aid in designing the Seakeeper foundation and the space around the Seakeeper.**

**NOTE: MAKE SURE NO OBSTRUCTIONS FROM THE HULL STRUCTURE CAN BE SEEN WITHIN THE INSIDE OF THE INSTALLATION TEMPLATE KIT (INSIDE THE MARKED RED LINES). REFERENCE SEAKEEPER DRAWING NO. 90487.**

**Section 1: MECHANICAL INSTALLATION**



**FIGURE 5 – EXPLODED VIEW OF INSTALLATION FIXTURE**

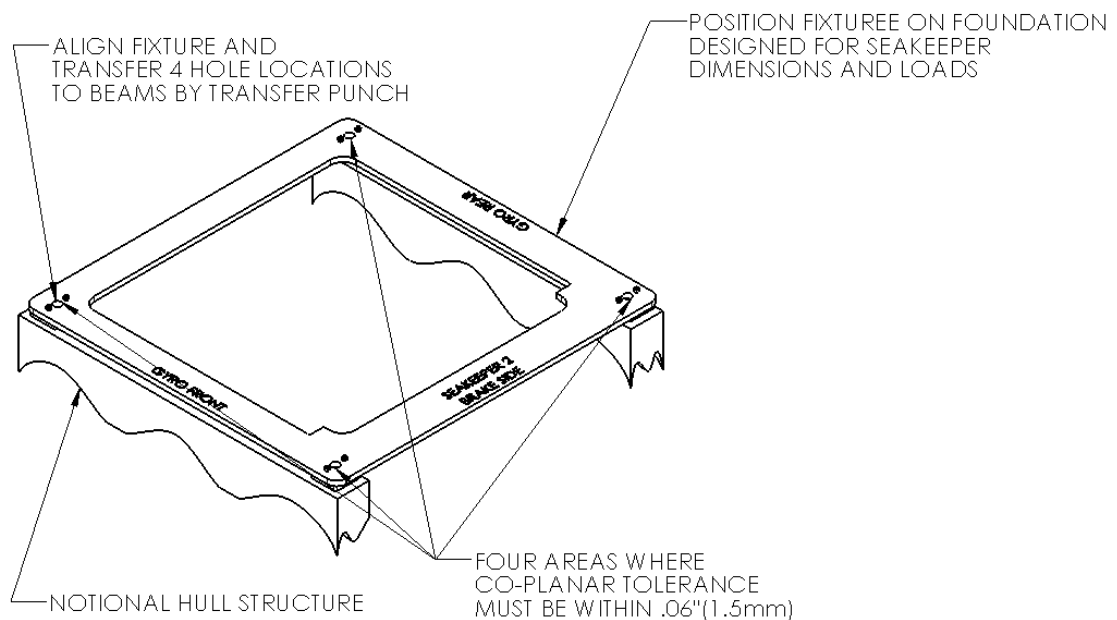


**CAUTION: Tight clearances from cable guide bands to hull structure. See above figure for dimensions and reference Seakeeper drawing NO. 90487 for complete Seakeeper 2 envelope.**

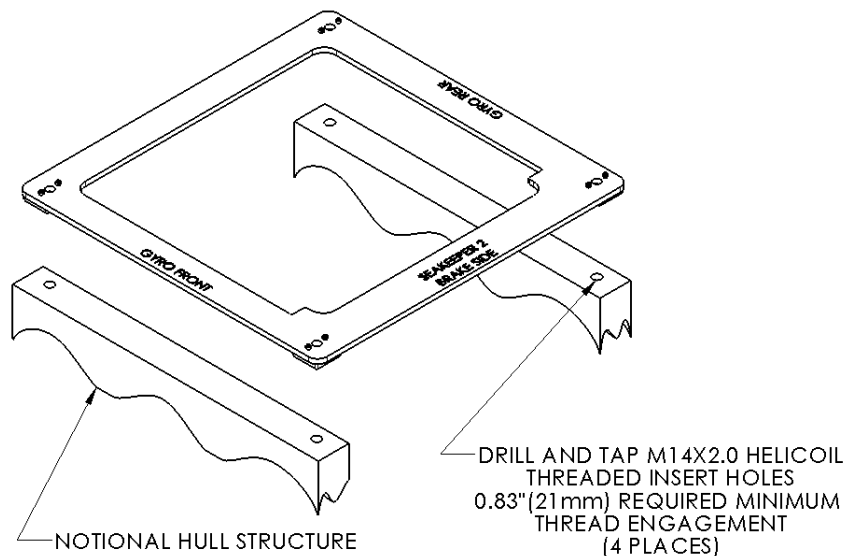
**Section 1: MECHANICAL INSTALLATION**

## 1.5.2 Transfer of Holes to Boat Structure

- 1) Lower assembled fixture onto hull structure.
- 2) **The four areas where the feet of the Seakeeper will rest should be coplanar to within .06" (1.5 mm). See Figure 10.**
- 3) Align fixture in desired location and transfer holes from fixture plate to the hull structure. Note that holes in fixture plate are  $\varnothing 0.60$  (15.138 mm).



- 4) Remove fixture and drill and tap M14X2.0 Helicoil threaded insert holes in hull structure at marked locations to mate with holes in the Seakeeper foundation. **Take special care to drill perpendicular to mounting surface.** A drill guide is recommended. Remove any impeding obstructions.

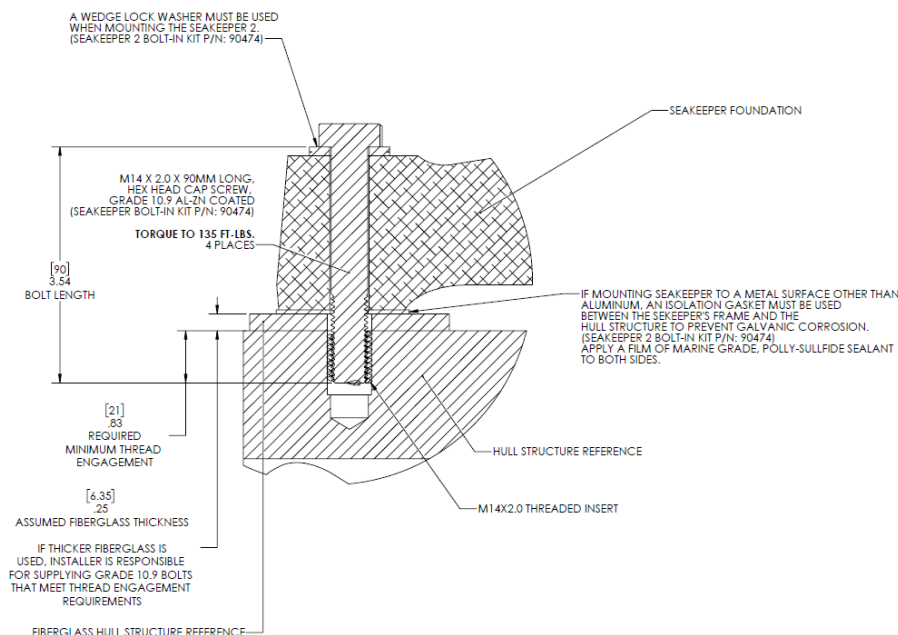
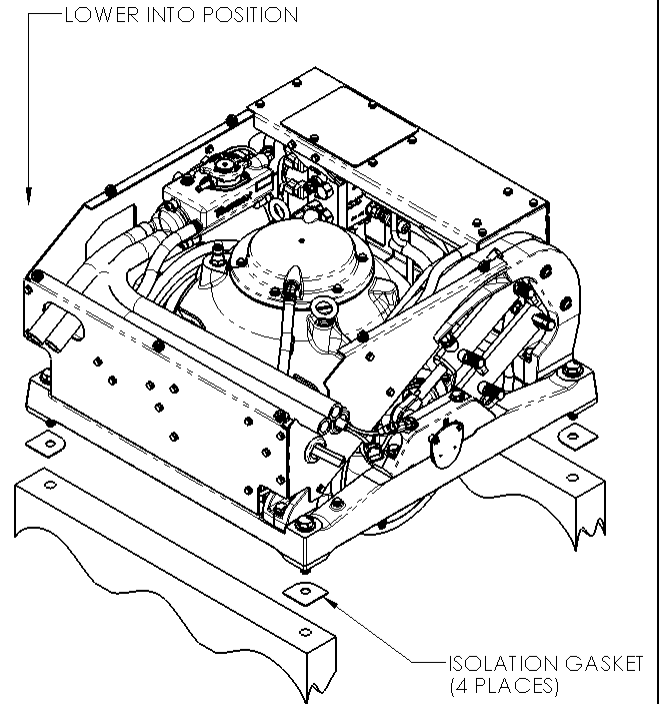




**Section 1: MECHANICAL INSTALLATION**

### 1.5.3 Installation of Seakeeper

- 1) Locate and position 4 isolation gaskets onto foundation beams (for metal to metal contacts only). NOTE: Sealant or caulk is recommended to be applied. Apply a small bead (approximately 4 mm wide) of sealant (silicone or caulk) between both mating surfaces of each isolation gasket where it contacts the beam and the Seakeeper. This will prevent water from wicking between the parts and setting up corrosion. Check isolation gasket alignment by test fitting bolts without any obstructions.
- 2) Lower Seakeeper into position onto the hull foundation beams and align over drilled holes.
- 3) Install Seakeeper supplied M14 fasteners Or Grade 10.9, M14-2.0 bolts to maintain a **minimum thread engagement of .83 in (21 mm)** – **apply a moderate coat of removable thread locker to the threads** of each bolt and include a small bead of sealant under each washer before installation.
- 4) **Torque all fasteners to 135 ft-lbs (183 N-m). New, Seakeeper supplied bolts must be used for each installation and reinstallation.**
- 5) Proceed to electrical and cooling portion of the installation.





**Section 1: MECHANICAL INSTALLATION**

## **1.6 Removal and Disposal**

### **1.6.1 Removal**

This section details basic instructions for removal of a Seakeeper 2 from a boat. The overall basic instructions are to reverse the installation instructions:

- 1) Disconnect seawater pump from heat exchanger and power connector on wiring harness.
- 2) Drain heat exchanger of all seawater.
- 3) Disconnect both Seakeeper input power cables.
- 4) Remove all installation fasteners.
- 5) Remove the Seakeeper unit using a spreader bar.

### **1.6.2 Disposal**

DO NOT disassemble the Seakeeper to a greater degree than necessary for removal from the boat. DO NOT dispose of a Seakeeper unit in a landfill. The unit must be shipped back to Seakeeper.

**Section 2: ELECTRICAL INSTALLATION**

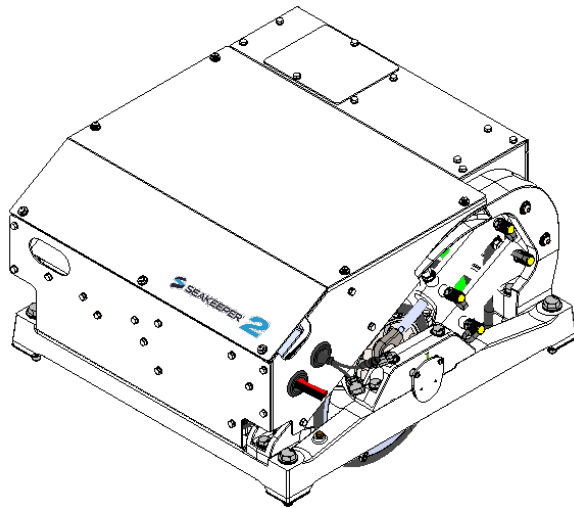
## 2.0 Introduction

This section for electrical installation explains how to mount the electrical equipment and how to connect the electrical cables.

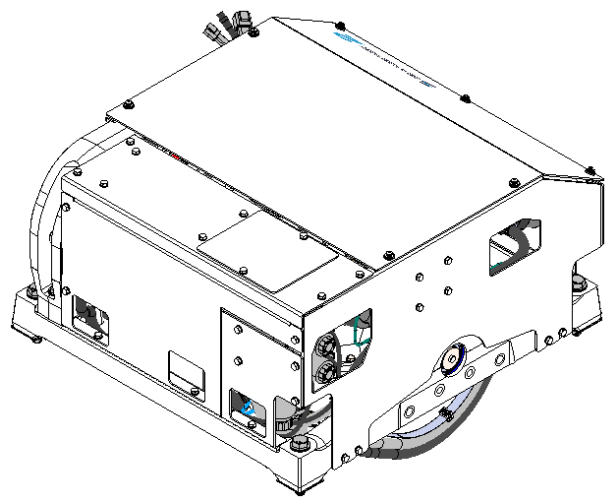
### Reference Documents & Drawings

**90469 Seakeeper 2 Hardware Scope of Supply**  
**90489 Seakeeper 2 Operation Manual**

**90470 Seakeeper 2 Cable Block Diagram**  
**90438 Color Operator Display Envelope and Mounting Details**



SEAKEEPER 2, Front Oblique View



SEAKEEPER 2, Rear Oblique View



12VDC Power Input Cable



SW Pump DC Power Cable



Terminator, Female



Tee Adapter



Touch Screen Display



2ft Cable



10m Cable

FIGURE 1 – ELECTRICAL EQUIPMENT FOR SEAKEEPER 2

**Section 2: ELECTRICAL INSTALLATION**

## 2.1 Electrical Equipment Mounting

### Precautions

- Each item of electrical equipment has specific mounting instructions. These instructions should be followed to insure proper function of the Seakeeper.



**Do NOT move Seakeeper mounted components from their locations or incorrect Seakeeper operation will result.**

#### 1. TOUCH DISPLAY MOUNTING INSTRUCTIONS, SURFACE MOUNT

- a. Console space required: Approx. 5.24 W x 3.70 H inches (133 x 94 mm)
- b. Mounting Instructions, Surface Mount: See drawing 90438 for details

#### 2. CAN COMMUNICATIONS TEE ADAPTER AND TERMINATOR MOUNTING INSTRUCTIONS

- a. Console space required, Rear: Approx. 4 W x 3 H inches (102 x 76 mm), rear
- b. Mounting Instructions: Rear mount on vessel console panel, within 2 ft (0.6m) of Display.
- c. Hardware required: One mounting screw for .197" (5 mm) diameter mounting hole on Tee Adapter.

**Section 2: ELECTRICAL INSTALLATION**

## 2.2 Electrical Equipment Power Connections

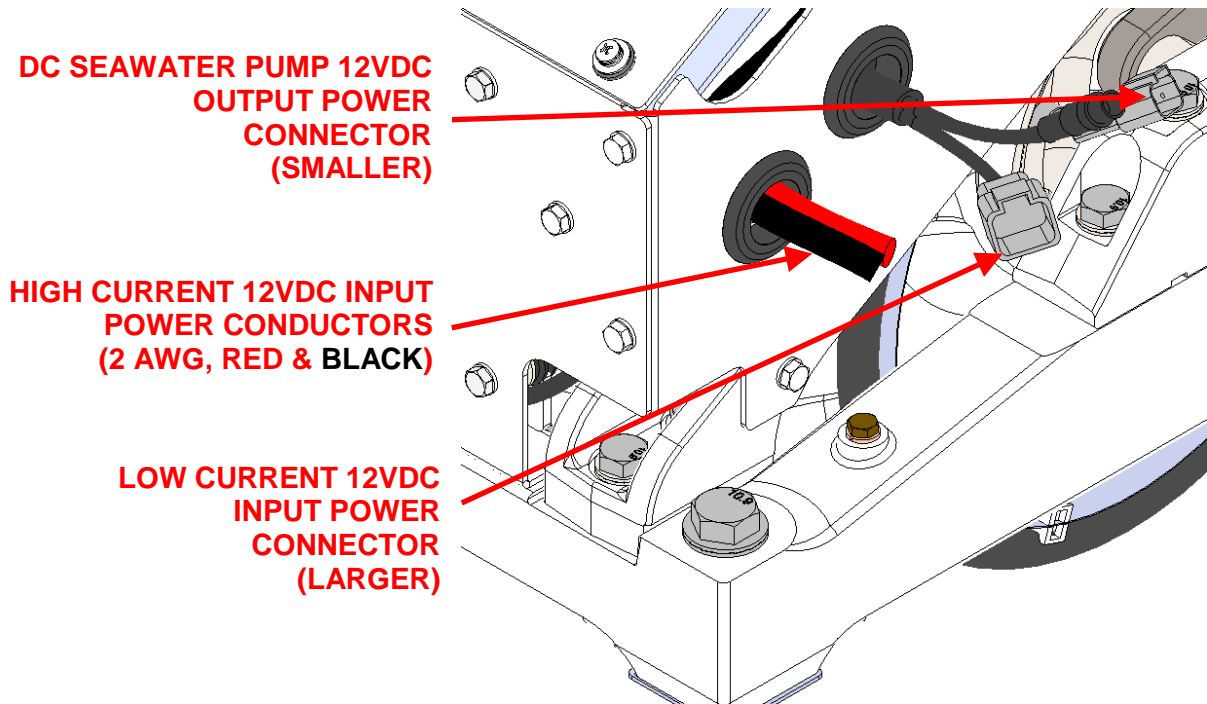


FIGURE 2 – SEAKEEPER 2 DC POWER INPUT & OUTPUT CONNECTIONS

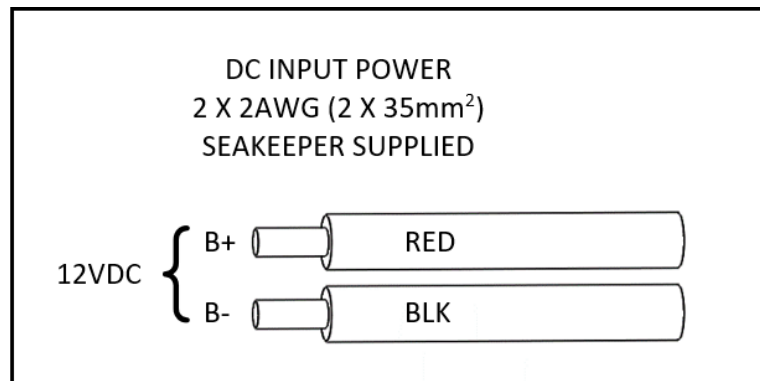
### 1. HIGH CURRENT 12V POWER INPUT

#### a. HIGH CURRENT 12 VDC POWER SOURCE REQUIREMENTS

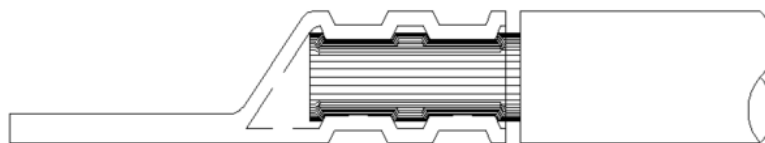
- i. Source: Battery Bank, 12 VDC, Marine, Deep Cycle
- ii. Alternate Source: Power Supply / Battery Charger, 12 VDC
- iii. Voltage Range: 10 – 16 VDC
- iv. Continuous Current: 75 Amps
- v. Overcurrent Protection: 100 Amp (Customer Supplied)

#### b. HIGH CURRENT 12 VDC POWER CONNECTION INSTRUCTIONS

- i. 2 AWG conductors to connect the high current DC input power are supplied as length 4m. Approximately 1m is routed within the gyro frame.
- ii. Conductor length may be increased, but **changing from 2 AWG to larger wire size does not allow longer length than 9m each**. The length limit is required to limit the inductance from the high current conductors.
- iii. Use the shortest length and most direct route to the battery bank as possible.
- iv. Bind plus (B+, Red) & minus (B-, Black) conductors together throughout entire length and do not coil.
- v. Connect plus conductor (B+, Red) through dedicated over-current protection device (customer supplied) and a dedicated isolation switch (customer supplied) then directly to battery plus terminal.
- vi. Connect minus conductor (B-, Black) directly to battery minus terminal.

**Section 2: ELECTRICAL INSTALLATION**

**FIGURE 3 – 2 AWG CONDUCTOR CONNECTIONS AT CIRCUIT BREAKER AND BATTERY**

- vii. If the 2 AWG high current 12V power input conductors are shortened or lengthened, use heavy-duty eyelet (closed end) terminal such as Molex 19221-0235 and follow instructions on Seakeeper drawing 90470, SK3 Cable Block Diagram, sheet 2.
- viii. The bare wire strands should extend fully into the barrel of the heavy-duty eyelet and be crimped in two places if possible then sealed with double-wall heat shrink tubing. Crimp heavy-duty terminals with Quick Cable 4245 Crimp Tool, Molex 19284-0034 Crimp Tool, or equivalent using manufacturer's instructions.


**FIGURE 4 – 2 AWG CONDUCTOR HEAVY-DUTY EYELET TERMINAL CRIMPS**

- ix. Finally, the heavy-duty eyelet and the end of the conductor insulation should be sealed with double-wall (adhesive-filled) heat shrink tubing.


**FIGURE 5 – TYPICAL 2 AWG CONDUCTOR EYELETS WITH SHRINK TUBING**

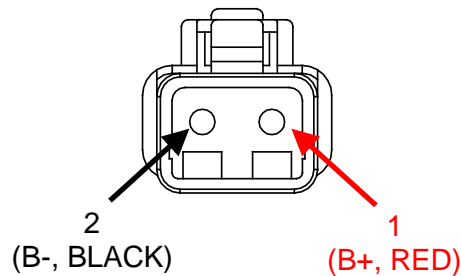
**Section 2: ELECTRICAL INSTALLATION**
**2. LOW CURRENT 12V POWER INPUT**
**a. LOW CURRENT 12 VDC POWER SOURCE REQUIREMENTS**

- i. Source: Battery Bank, 12 VDC, Marine, Deep Cycle
- ii. Alternate Source: Power Supply / Battery Charger, 12 VDC
- iii. Voltage Range: 10 – 16 VDC
- iv. Continuous Current: 9 Amps
- v. Overcurrent Protection: 15 Amp (Customer Supplied)

**b. LOW CURRENT 12 VDC POWER CONNECTION INSTRUCTIONS**


**Reversing polarity on the DC power input to the Seakeeper can result in damaging the electronics in the control system.**

- i. Install Seakeeper provided DC Power Input Cable, P/N: 20248 as CABLE 7 to battery bank.
- ii. Connect plus conductor (B+, Red) through dedicated over-current protection device (customer supplied).
- iii. Connect minus conductor (B-, Black) directly to battery minus terminal.
- iv. Before connecting CABLE 7 to Seakeeper, check for proper voltage and polarity with a DC multimeter using Figure 6 below.



**FIGURE 6 – LOW CURRENT 12 VDC POWER INPUT CONNECTOR CONTACT ASSIGNMENTS (FRONT)**

- v. Connect CABLE 7 to Low Current 12 VDC power input connector on the Seakeeper.



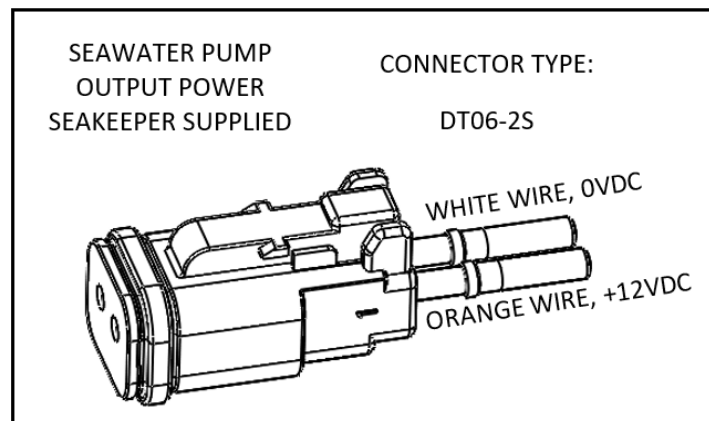
**When energizing DC power the first time, if display does not power up immediately then disconnect and inspect connector polarity.**

**Section 2: ELECTRICAL INSTALLATION**
**3. DC SEAWATER PUMP 12V POWER OUTPUT**
**a. DC SEAWATER PUMP 12 VDC POWER SOURCE SPECIFICATIONS**

- i. Source: 12 VDC from the Seakeeper
- ii. Alternate Source: None
- iii. Voltage Range: 10 – 16 VDC
- iv. Continuous Current: < 3 Amps
- v. Overcurrent Protection: 3 Amp (on the Seakeeper)
  1. EATON BUSSMANN ATC-3 or equivalent is contained in a watertight fuse holder (see Figure 10)

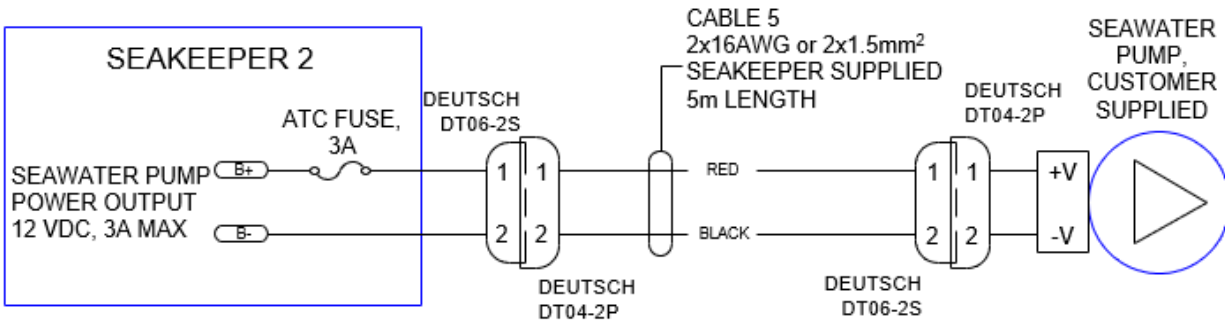
**b. DC SEAWATER PUMP 12 VDC POWER CONNECTION INSTRUCTIONS**

- i. Locate CABLE 5 for DC power output to the customer supplied Seawater Pump, 2 x 16AWG (2 x 1.5 mm<sup>2</sup> CSA) cable, 16 ft (5m) length, Seakeeper supplied
- ii. Pumps rated at 12 VDC, 3 Amps max., Customer-supplied, must be configured with a Deutsch DT series, 2-pin receptacle to mate with the connector shown in Figure 7.
  1. TE Connectivity (Deutsch) DT04-2P Receptacle, 2-Way, for Male Pins (qty 1)
  2. TE Connectivity (Deutsch) 0460-202-1631 Pin, Solid, Gold-plated, Size 16, 16-20AWG (qty 2)
  3. TE Connectivity (Deutsch) W2P Wedgelock for 2-Way DT Receptacle (qty 1)
- iii. CABLE 5 must be routed and installed in the vessel from the Seakeeper (male end) to the DC Seawater Pump (female end). (See Figure 7.)

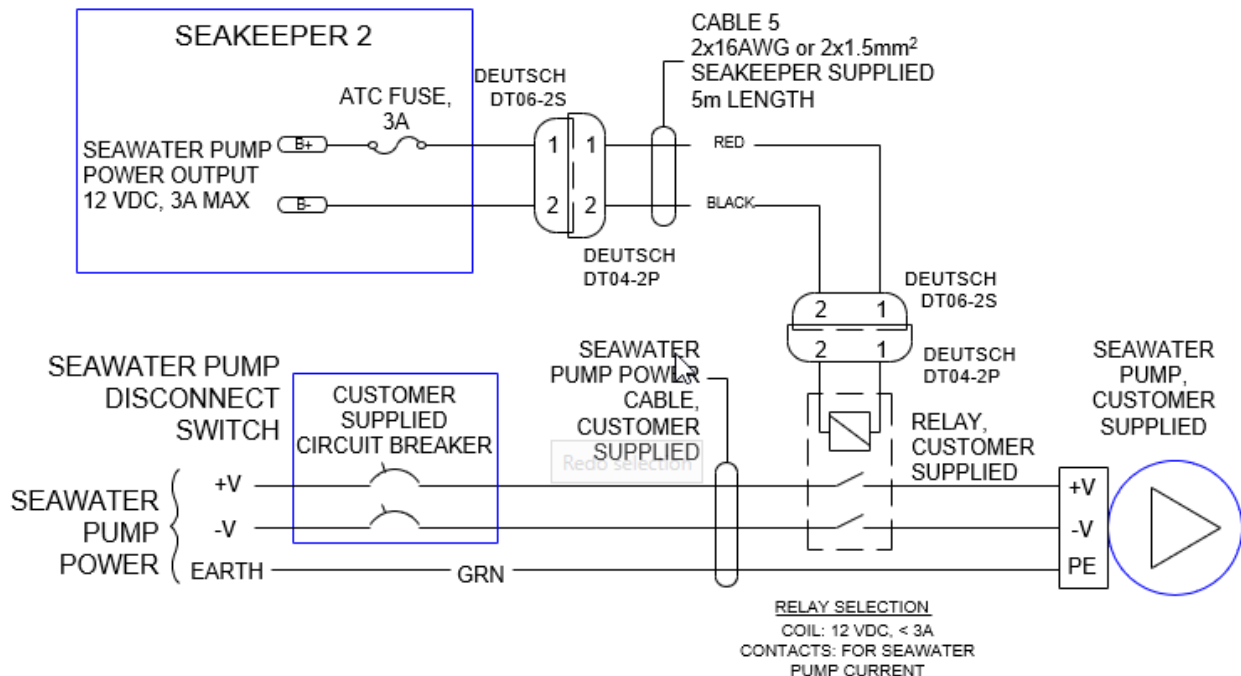

**FIGURE 7 – CABLE 5, SEAWATER PUMP DC OUTPUT POWER CABLE END**

**Section 2: ELECTRICAL INSTALLATION**

- iv. Connect the 12VDC wires in CABLE 5 to a 3 Amp maximum, Seawater Pump (approximately 36W) according to Figure 7.
- v. The recommended wiring is shown in Figure 8. Refer to Figure 7 for CABLE 5 wire connections.


**FIGURE 8 – RECOMMENDED WIRING FOR SEAWATER PUMPS**

- c. SEAWATER PUMP POWER CONNECTION INSTRUCTIONS FOR OTHER VOLTAGE OR OTHER CURRENT
  - i. If the customer-supplied Seawater Pump is not rated for 12VDC, 3A or less, the CABLE 5 output may be used to switch a customer-supplied relay.
  - ii. Locate CABLE 5 for DC power output to the Seawater Pump from the Seakeeper.
  - iii. The recommended wiring is shown in Figure 9. Refer to Figure 7 for Cable 5 wire connections.


**FIGURE 9 – RECOMMENDED WIRING FOR SEAWATER PUMPS NOT 12 VDC  
OR NOT 3A MAX**



**Section 2: ELECTRICAL INSTALLATION**

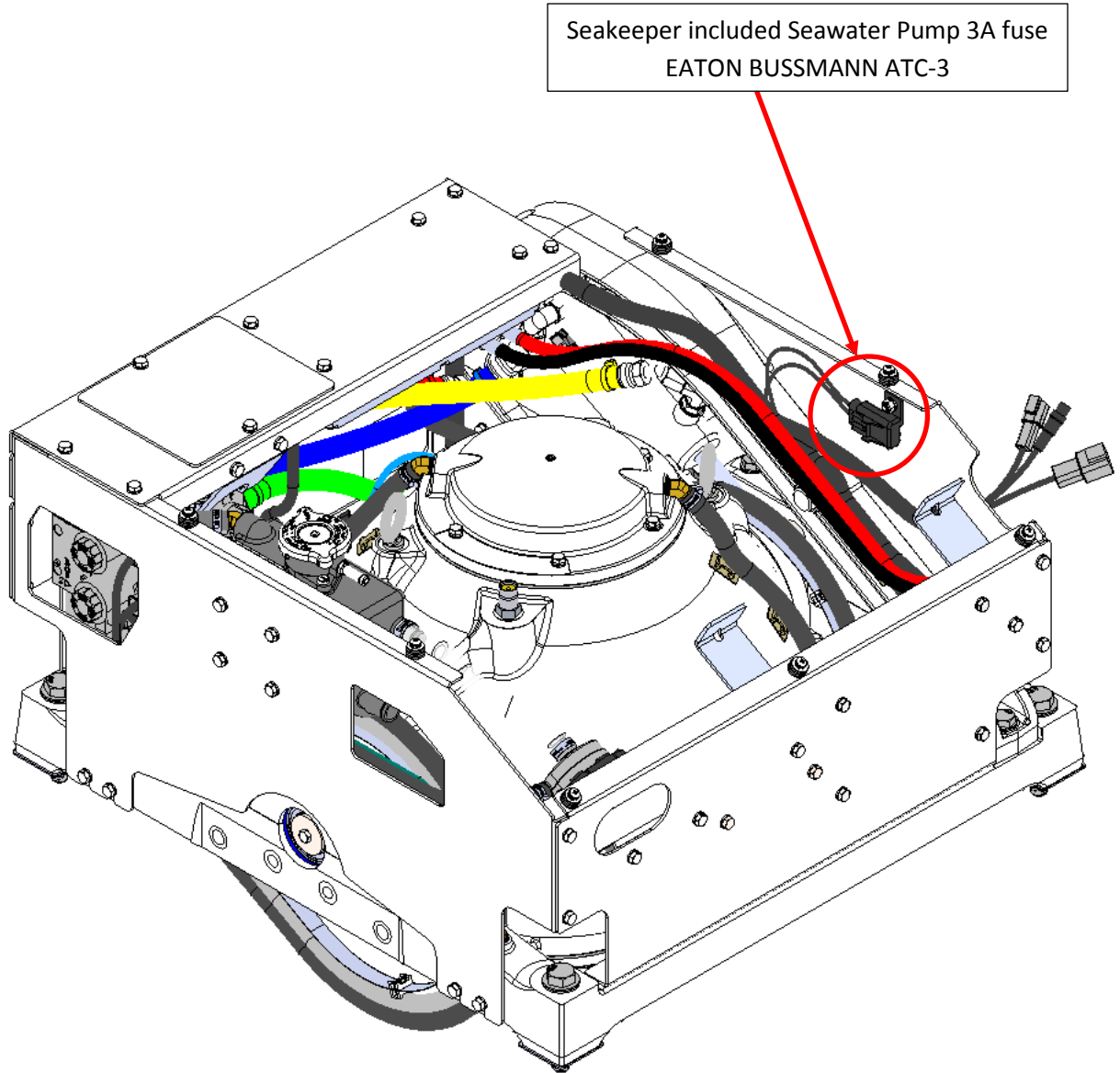


FIGURE 10 – SEAKEEPER INCLUDED SEAWATER 3A FUSE LOCATION

**Section 2: ELECTRICAL INSTALLATION**

## 2.3 Electrical Equipment Ground Connections

### 1. SEAKEEPER TO VESSEL GROUND CONNECTION INSTRUCTIONS

- a. Connect the Seakeeper foundation to vessel ground.
  - i. Install CABLE 6 (4AWG or 25 mm<sup>2</sup>, Customer Supplied) from the M6 brass ground stud on the rear brace to a suitable vessel ground. *Note: ONLY USE THIS LOCATION FOR GROUNDING THE SEAKEEPER TO THE VESSEL GROUND.*

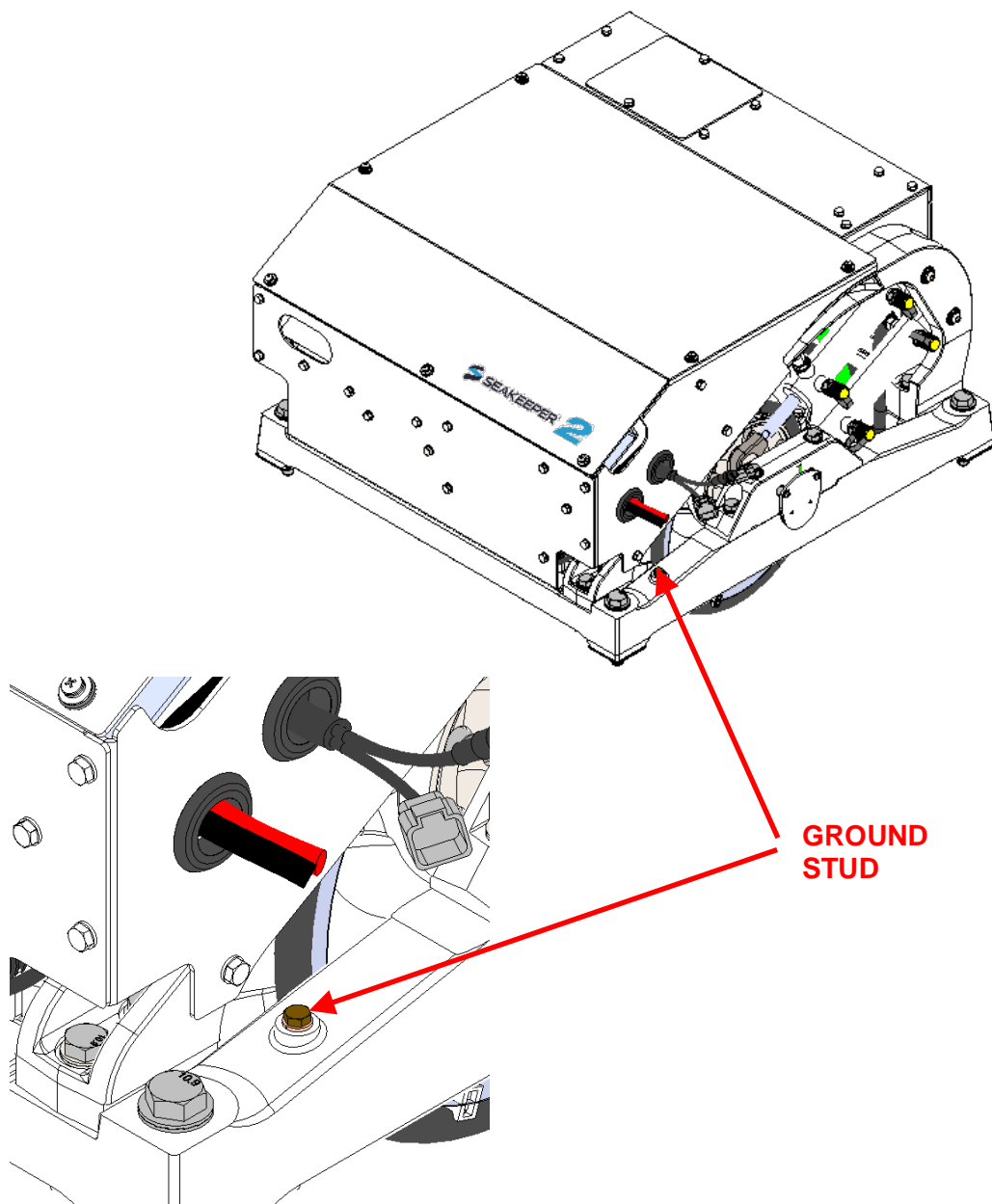


FIGURE 11 – GROUND STUD ON FRAME

**Section 2: ELECTRICAL INSTALLATION**

## 2.4 Operator Station

This section explains the connection between the Operator Station equipment and the Seakeeper.

### Reference Drawing - 90470 Seakeeper 2 Cable Block Diagram

#### 1. DETERMINE LOCATION OF OPERATOR STATION

- a. The desired location of the Operator Station must be determined with respect to the vessel arrangement.
- b. The operator display should be located on the bridge console.
- c. Figure 12 below shows the CANbus communications link for the Operator Station. The Terminator goes on one the far end of the Tee Adapter from the Seakeeper.

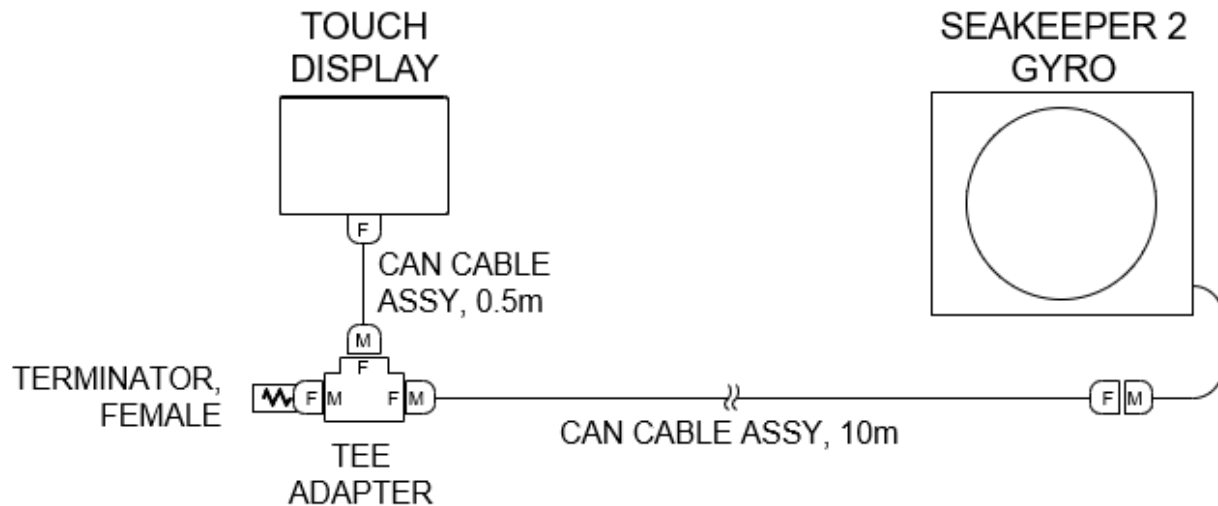


FIGURE 12 – SERIAL COMMUNICATIONS LINK FOR OPERATOR STATION

#### 2. ROUTE CAN COMMUNICATIONS CABLE

- a. The CAN Cable Assembly (30295, CABLE 3) is a 10 meter shielded cable and the largest connector is a molded plug with maximum outer diameter of .58 inch (14.8mm).
- b. CABLE 3 must be routed and installed in the vessel from the Seakeeper (female end) to the Tee Adapter (male end) at the Operator Station.

#### 3. INSTALL OPERATOR STATION EQUIPMENT

- a. The Operator Station equipment is installed at the selected location using Electrical Equipment Mounting Instructions in Section 2.1.

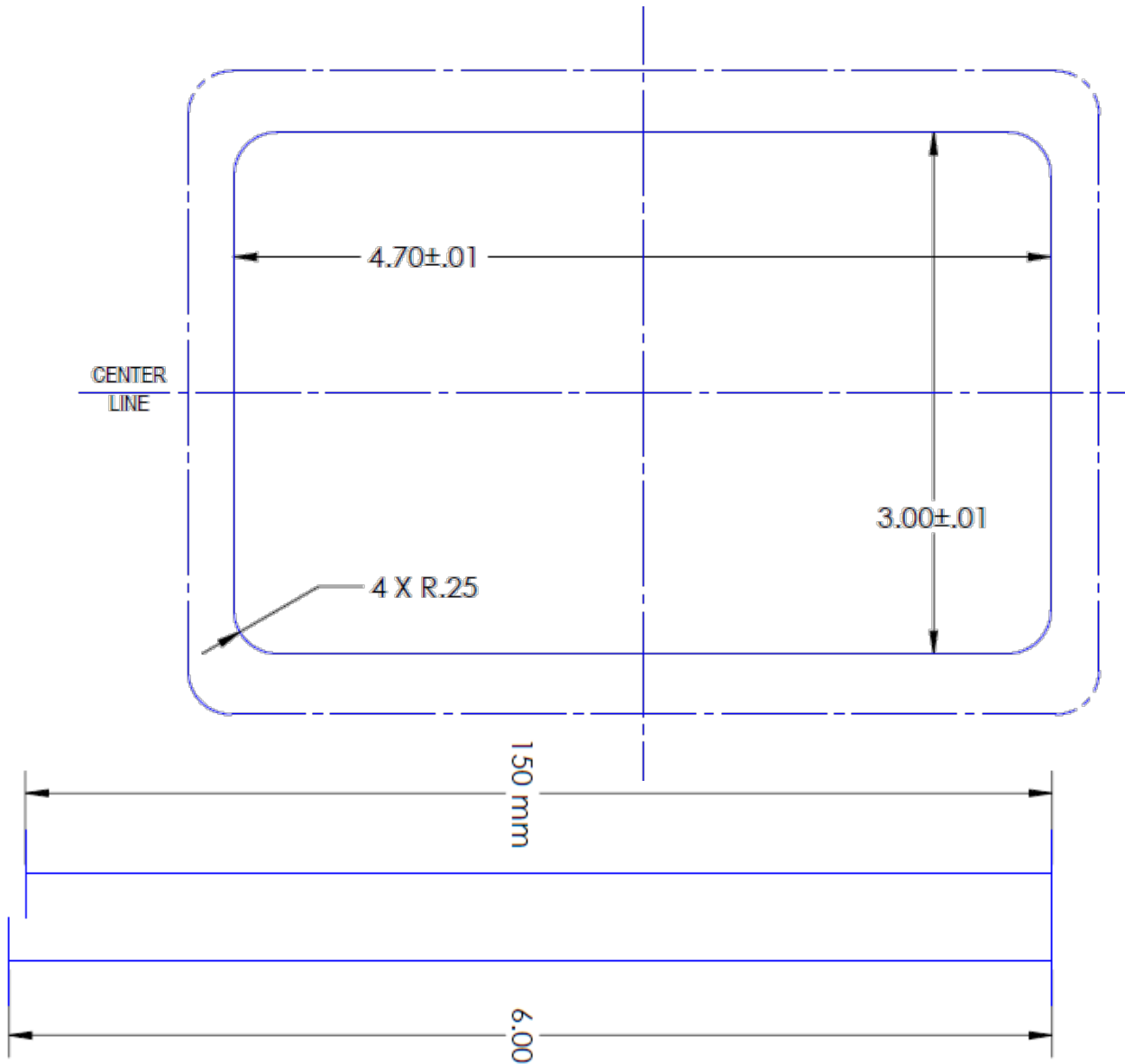
#### 4. CONNECT OPERATOR STATION EQUIPMENT

- a. The Operator Station equipment is connected in accordance with the Cable Block Diagram, 90470.

**Section 2: ELECTRICAL INSTALLATION**

## 2.5 Display Installation Template

The following template is for mounting; before using this template, measure to ensure that the shown size is actual.



SCALE LINES

DISPLAY MOUNTING TEMPLATE

**Section 3: COOLING INSTALLATION**

### 3.0 Introduction

The Seakeeper 2 is shipped with the cooling circuit filled and ready for use. Only a quick confirmation of glycol level is required.

#### Reference Drawings

*90469 Seakeeper 2 Hardware Scope of Supply*

*90470 Seakeeper 2 Cable Block Diagram*

*90490 Seakeeper 2 Cooling Water Schematic*

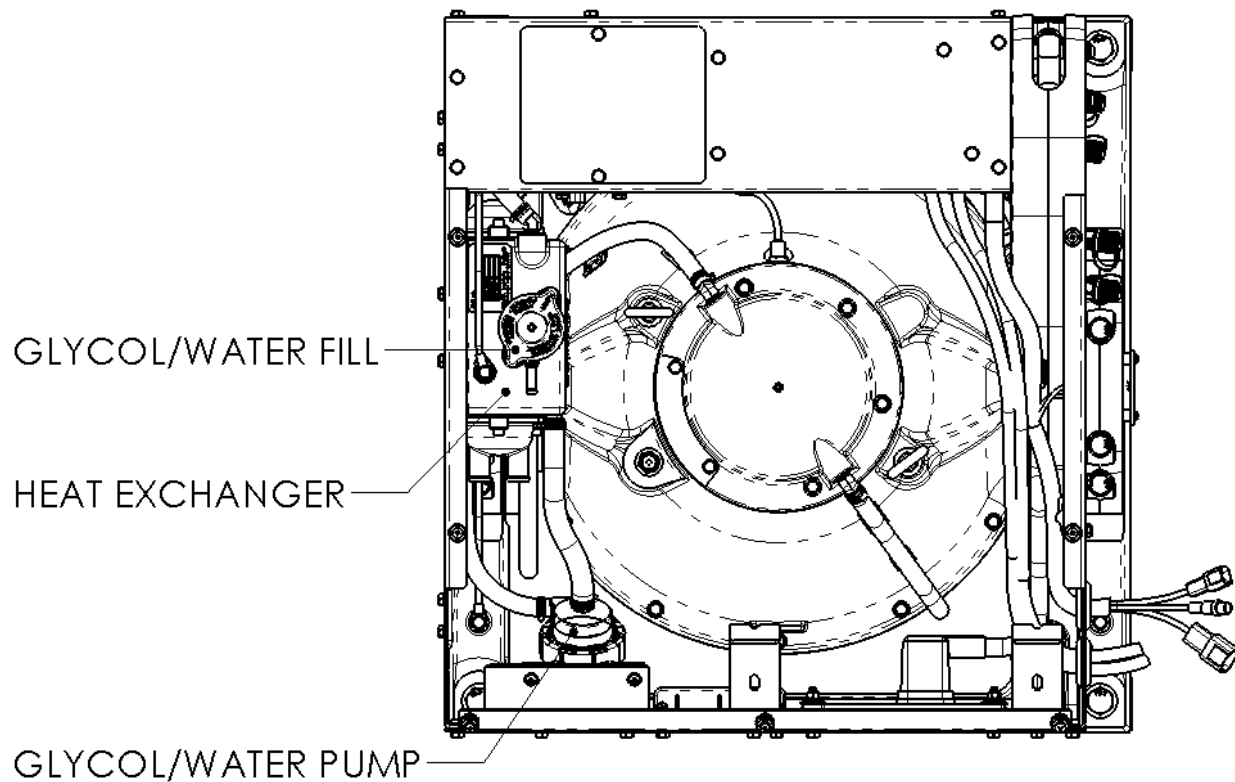
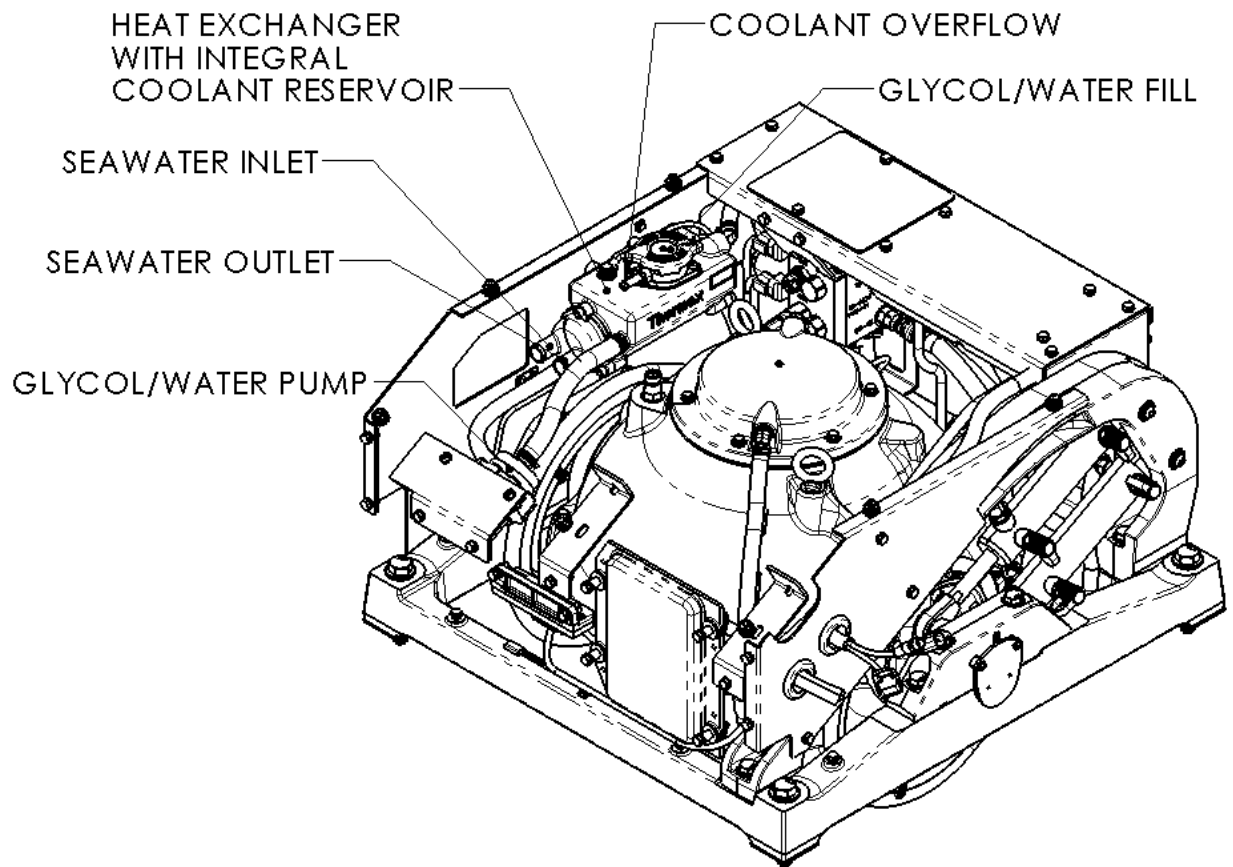


FIGURE 1 – SEAKEEPER 2

**Section 3: COOLING INSTALLATION****FIGURE 2 – SEAKEEPER 2 COOLING COMPONENTS**

**Section 3: COOLING INSTALLATION**

### 3.1 Precautions

- Installer is responsible for supplying a dedicated seawater pump and associated plumbing. Seawater connections on the Seakeeper heat exchanger mate with ¾ inch (19 mm) hose.
- The seawater output from the Seakeeper powers the seawater pump or central seawater valve. This pump or valve must operate on 12 VDC and consume less than 3 amps. Pumps requiring other voltages or higher current can still be controlled by using this supply from the Seakeeper to trigger an installer-supplied contactor, but a separate source of power must be provided.
- A self-priming seawater pump (customer/installer supplied) may be required due to installation location to maintain water flow in all underway conditions where cavitation near the intake may occur and potentially cause an air-lock condition restricting seawater flow to the heat exchanger.
- Maximum allowed seawater pressure in heat exchanger is 20 psi (1.4 bar)
- **Seawater flow requirement through heat exchanger is 2 GPM (7.6 LPM) minimum and 6 GPM (22.7 LPM) maximum under all operating conditions of the boat.** When sizing seawater pump, installer should factor in losses for raw water plumbing. In addition to initial operation at dock, new Seakeeper installations should be checked to be within the flow requirements while vessel is at speed. Flows higher than 6 GPM (22.7 LPM) could affect heat exchanger life.

### 3.2 Adding Coolant

- 1) Cooling system is filled to proper level when shipped, with a mixture of 50% ethylene glycol and 50% distilled water. Clear tube between thermostat housing and reservoir should be filled with colored coolant mixture. If level has dropped, check for evidence of leaks at all connections before adding fluid as described below. If coolant is at the correct level, skip to seawater connection in section 3.3.

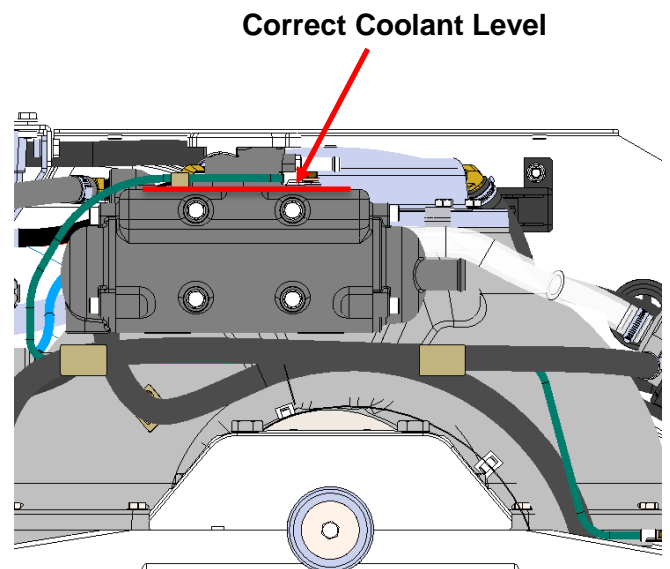


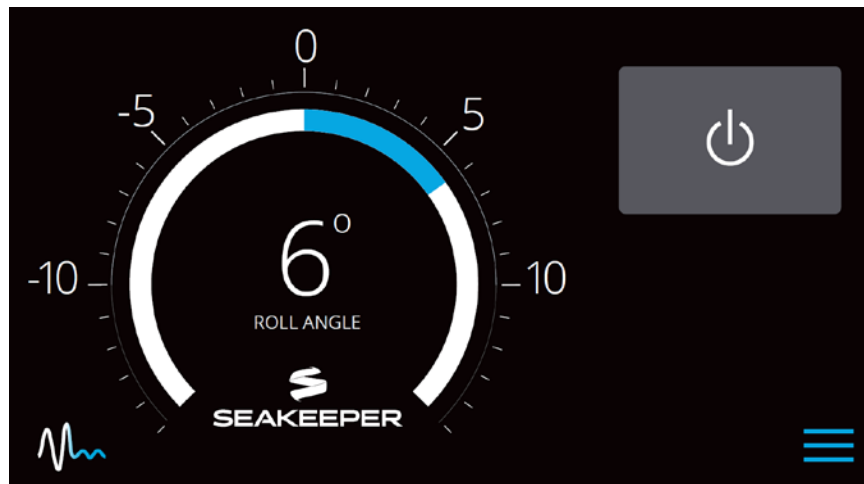
FIGURE 3 – SEAKEEPER 2 COOLANT LEVEL


**Section 3: COOLING INSTALLATION**

- 2) Mix 50% ethylene glycol with 50% distilled water in a clean container. Refer to Table 1 or glycol manufacturer's literature for freezing points. It is required that ethylene glycol with corrosion inhibitors be used. Most commercially available glycol has these additives standard.

Ethylene Glycol Solution (% by volume)		0	10	20	30	40	50	60
Temperature	(°F)	32	23	14	2	-13	-36	-70
	(°C)	0	-3	-8	-16	-25	-37	-55


- 3) Remove pressure cap on top of reservoir. Pour mixture in until level reaches top face of the heat exchanger as shown in Figure 3. Filling reservoir above this level will not cause any damage but coolant may be expelled from pressure relief port below cap due to normal thermal expansion of coolant.
- 4) Connect 12 V to controller.
- At the Display check for any ALARMS



- Press the POWER ON/OFF button 
- The flywheel will start to spin and the glycol pump will start.
- Recheck glycol level with fluid circulating in coolant circuit. Sight down inside reservoir and check that coolant level is above upper port on reservoir as shown in Figure 3. Replace cap.



**Section 3: COOLING INSTALLATION**

- After several minutes of running, press POWER ON/OFF button  to turn power off to the Seakeeper.

- 5) The cooling system is self-purging. If small amounts of air are in the system, they will most likely be dislodged during the first sea trial. Recheck level after sea trial and add fluid if required.

### 3.3 Connecting Seawater to Heat Exchanger

- 1) Connect seawater from installer supplied pump to lower 3/4" (19 mm) hose barb on heat exchanger. Use the same practices as other below waterline seawater plumbing. Required flow rate is 2 GPM (7.6 LPM) minimum and 6 GPM (22.7 LPM) maximum.
- 2) Connect seawater discharge (upper hose barb) to overboard drain. Use the same practices as other below waterline seawater plumbing.
- 3) In addition to initial operation at dock, new Seakeeper installations should be checked for minimum 2 GPM (7.6 LPM) flow while vessel is at speed and when backing down. If no other method of confirming flow is available, discharge line may be temporarily diverted to a bucket. Flow is calculated from time to fill a known volume. A self-priming seawater pump (customer/installer supplied) may be required due to installation location to maintain water flow in all underway conditions where cavitation near the intake may occur and potentially cause an air-lock condition restricting seawater flow to the heat exchanger.
- 4) Inspect raw water plumbing after sea trial for any signs of leakage.
- 5) Heat exchanger contains a removable end-cap to provide access for cleaning the tube bundle.

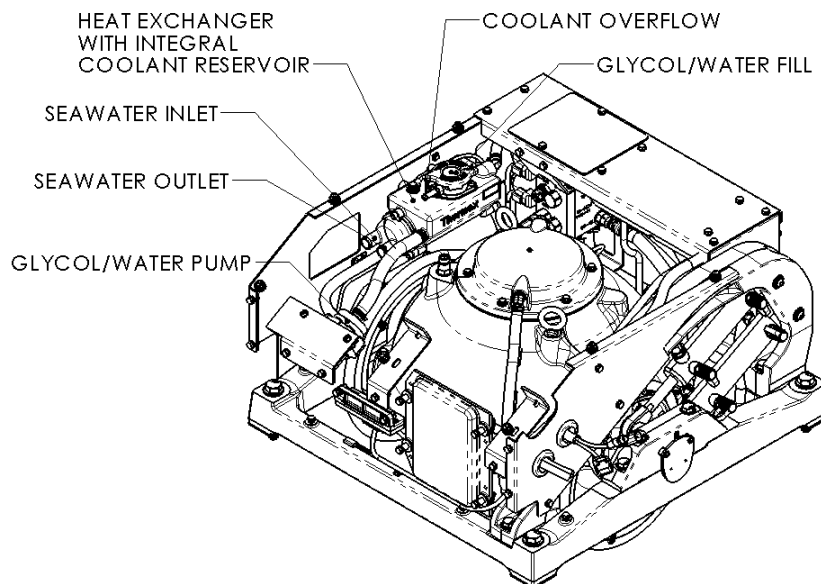


FIGURE 4 – SEAKEEPER 2 SEAWATER CONNECTIONS

**Section 4: STARTUP**

## 4.0 Introduction

This section describes the first startup of the Seakeeper.


Also reference Seakeeper Document # 90489, Seakeeper 2 Operation Manual.

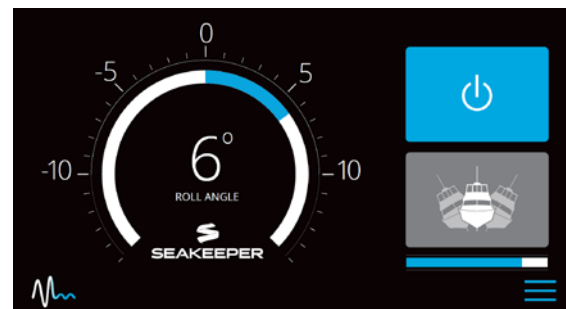
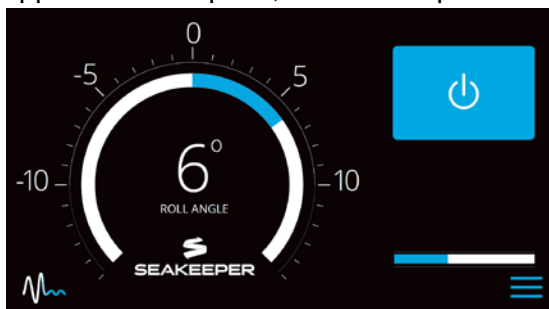


- **Previous sections for mechanical, electrical and cooling installation must be completed before this startup sequence is initiated.**
- **Before continuing, covers must be installed unless the Seakeeper is inaccessible and there is no risk to injury. Also, the area around the Seakeeper must be clear of personnel and equipment.**

## 4.1 Startup Instructions


- 1) Energize 12 VDC 15A supply at the customer supplied electrical disconnect.
- 2) Supply 12 VDC 100A to Motor Drive Box at customer supplied electrical disconnect.
- 3) If seawater pump for the Seakeeper is not supplied though cable from Motor Drive Box, turn on the boat's DC dedicated circuit breaker that supplies power to the seawater pump.
- 4) With system powered up check the display for any ALARMS. If there are any ALARMS present they must be corrected first.

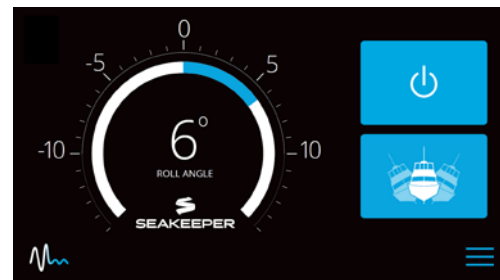
- 5) Press the Seakeeper ON/OFF Button on Display.  The progress bar will appear and indicate how soon the Seakeeper will be available for stabilization. When the Seakeeper is initialized and up to minimum operating speed the stabilize button will appear. At this point, the Seakeeper is available for stabilization.





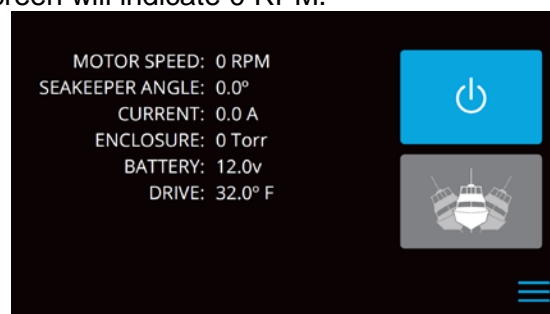
**Section 4: STARTUP**

- 6) The seawater pump will operate for two minutes after the ON/OFF button on the display was depressed. After that the seawater pump output is turned on and off based on the temperature of the Seakeeper. Confirm pump operation and flow rate, if practical. Required flow is 2 GPM (7.6 LPM) minimum and 6 GPM (22.7 LPM) maximum.
- 7) Verify that there are no ALARMS present. If an ALARM is present it will be displayed.
- 8) When the Seakeeper reaches its maximum operating speed where maximum stabilization is available, the progress bar will disappear and the Seakeeper is available

for maximum stabilization. Press the stabilize button.  The button will turn blue indicating that the Seakeeper is stabilizing the roll motion.



- 9) Verify that there are no alarms. If an ALARM is present it will be displayed.
- 10) Press the STABILIZE Button  to turn stabilization off. Then press the Seakeeper ON/OFF Button  to power the Seakeeper down.
- 11) During normal operation, the Seakeeper should be stopped when stabilization is no longer required. This maximizes long term life as it allows the Seakeeper to start the coast down cycle before cooling is shutoff. Once the vessel is secured in the slip and the crew has shut down the generator and engines, the DC breakers that control the Seakeeper should be switched to the OFF position. The Seakeeper will continue to spool down to zero rpm. No cooling is required during this time. Note the Seakeeper 2 will take 16+ hours to coast down to zero rpm from full speed. When the flywheel has stopped the service screen will indicate 0 RPM.



**Section 5: INSTALLATION CHECKLIST AND SUPPLIES**

**Please Complete Checklist and E-mail to [customerservice@seakeeper.com](mailto:customerservice@seakeeper.com)  
or telefax to +1.410.326.1199**

## **5.0 Installation Checklist**

### Mechanical Checklist (reference Installation Manual Section 1)

- Seakeeper Foundation Installed in Hull**
- Seakeeper supplied foundation bolts torqued to specification**
- Clearances around Seakeeper meet specifications and no obstructions are within the Seakeeper envelope**

### Electrical Checklist (reference Seakeeper Drawing 90470 & Installation Manual Section 2)

#### **Mount Components**

- Display (near helm)**

#### **Connect Seakeeper and Customer Supplied Cables**

- Cable 7 (Seakeeper supplied)– Connect Cable 7 from Seakeeper 12VDC 15A power at customer supplied connection box, or directly to a circuit breaker.**
- Plug connector of Cable 7 into mating connector on the Seakeeper wire harness.**
- Cable 6 (customer supplied) – Install lugs on both ends of customer supplied 4 AWG ground cable.**
- Connect one end of Cable 6 to nearest vessel ground and other end to Seakeeper foundation.**

#### **Connect Seakeeper Supplied Cables**

- Conductors 1&2 (Seakeeper supplied) – Connect Conductors 1&2 from Drive Box to 12 VDC 100A at customer supplied connection box or directly to circuit breaker.**
- Cable 5 (Seakeeper supplied)– Connect female end of Cable 5 to customer supplied 12 VDC 3A seawater pump.**
  - Plug male end connector of Cable 5 into mating connector on the Seakeeper wire harness**

**Section 5: INSTALLATION CHECKLIST AND SUPPLIES**

- Cable 3 (Seakeeper supplied)– Connect female end of CAN communications Cable 3 to mating connector on the Seakeeper wire harness**
- **Route CAN communications Cable 3 from the Seakeeper to helm (male end goes to helm)**
- **Connect male end of CAN communications Cable 3 at helm to CAN Tee Adapter**
- **Connect Display and Seakeeper supplied Cable 4 to CAN Tee Adapter with CAN Terminator**

Cooling Checklist (reference Installation Manual Section 3)

- Verify coolant level in heat exchanger coolant reservoir.**
- Connect seawater hoses / open sea cocks to heat exchanger and test seawater pump.**
- Verify 2 GPM (7.6 LPM) minimum and 6 GPM (22.7 LPM) maximum seawater flow through heat exchanger under all operating conditions of the boat. (The seawater pump output will operate for two minutes after the Seakeeper is turned on. During operation, the seawater pump output is turned on and off based on the temperature of the Seakeeper)**

Startup Checklist (reference Installation Manual Section 4 & Operation Manual Sect. 2)

- Remove lifting bolts and Install cover panels**
- Turn on 12 VDC 15A circuit breaker**
- Turn on 12 VDC 100A circuit breaker**
- Verify display works and no alarms are present**
  1. **If display does not work, turn off both circuit breakers immediately**
  2. **Check polarity of 12VDC 15A power per Section 2.2.5**
- Follow instructions in Section 4.1 of Installation Manual to turn on the Seakeeper**
- Verify seawater pump turns on when the Seakeeper is turned ON**
- Verify that no ALARMS are present**
- Follow instruction in Section 4.1 of Installation Manual to turn off the Seakeeper**
- DC power and seawater pump may be turned off after the Seakeeper is turned off by placing the Seakeeper in LOCK mode and Turning the Seakeeper off**
- Seakeeper 2 takes 16+ hours to coast down to zero rpm from full speed**

**Section 5: INSTALLATION CHECKLIST AND SUPPLIES**

## 5.1 Required Supplies needed for Seakeeper Installation (not supplied with the Seakeeper)

Item	Description	Qty	Installation Manual Reference Section	Other Reference	System
1	Soundproofing Considerations		1		Mechanical
2	Spreader bar for lifting the Seakeeper		1		Mechanical
3	Hose clamps for seawater plumbing to 3/4" (19 mm) hose barb (2 per hose barb)	4	3		Cooling
4	M6 terminal lug for grounding Seakeeper at rear brace	1	2.3.1		Electrical
5	Cable, 4 AWG, for grounding Seakeeper at foundation to vessel ground (used with item 4)	AR	2.3.1	Dwg 90470	Electrical
6	Seawater pump, 12 VDC 3A (Fuse protection included in Seakeeper wiring harness)	1	2.2.3		Electrical
7	Relay for seawater pump control (Not required if using 12 VDC 3A pump)	1	2.2.3		Electrical
8	100A Circuit breaker for Conductor 1	1			Electrical
9	15A Circuit breaker for Cable 7	1			Electrical

AR = As Required  
Dwg = Drawing

### List of common tools that may be required for installation

Item	Description	Use
1	Wire cutter	DC Power cables
2	Wire stripper	DC Power cables
3	3 mm hex key	Gimbal sensor mount plate
4	2.5 mm hex key	Gimbal angle sensor
5	1/4 inch nut driver	Hose clamps
6	Quick Cable 4245 Crimp Tool, Molex 19284-0034 Crimp Tool, or equivalent	Power cables
7	Utility knife	Scoring cable jackets